

# MAGNUSON

## SUPERCHARGERS

### C8 Corvette TVS2650 Supercharger Installation Guide

(Powertrain removed from vehicle)

Kit P/N: 01-26-62-085-BL (Coupe Only, w/ cast lid)

and

Kit P/N: 01-26-62-087-BL (Convertible or Optional appearance upgrade for Coupe, w/ billet lid)



**PREMIUM 91 OCTANE GASOLINE FUEL REQUIRED**



#### ATTENTION!

Your **MAGNUSON SUPERCHARGER** kit  
is sensitive to corrosion!

Use **only the vehicle manufacturer  
recommended coolant for your engine in  
the intercooler system as well.**

Magnuson Superchargers  
1990 Knoll Drive, Bldg A, Ventura, CA 93003  
(805) 642-8833 phone  
[magnusonsuperchargers.com](http://magnusonsuperchargers.com)

## General Notes

### Magnuson Supercharger Kit: C8 TVS2650 (Powertrain Removed from Vehicle)

This manual details the process to install your supercharger kit with the powertrain **REMOVED** from the vehicle. If you are not planning to remove the powertrain, follow the alternate set of instructions (89-89-57-047).

**IMPORTANT: Read through the first 5 pages of this manual, especially page 5 which details the process for unlocking and verifying your ECM, prior to installing your supercharger.**

Please take a few moments to review this manual thoroughly before you begin work: Make a quick parts check to be certain your kit is complete (see Bill of Material (BOM) parts list inside the accessory box). If you discover shipping damage or shortage, please call our office immediately. Take a look at exactly what you are going to need in terms of tools, time, and experience. Review our limited warranty with care.

**Use only premium gasoline fuel, 91 octane or better. The use of non-premium fuel can cause engine failure and will void your warranty.**

Magnuson Products recommend that you run a minimum of one tank of premium 91 octane or better fuel through your vehicle prior to installation of the system to prevent any possible damage that may occur due to running the supercharged engine on lower octane fuel.

**DO NOT RUN E85 FUEL WITH THE SUPERCHARGER.**

**DO NOT USE OCTANE BOOSTERS. If you have used octane boosters in the past you will have to replace your spark plugs and the O2 sensors.**

Magnuson Superchargers systems are designed for engines and vehicles in “GOOD” mechanical condition. Magnuson Superchargers recommend that a basic engine system “Health Check” be performed prior to the installation of this supercharger system. Be sure to check for any pending or actual OBDII codes and fix/repair any of the stock systems/components causing these codes. If there are codes prior to the installation they will be there after the installation.

Magnuson Superchargers also recommend the following services to be performed on your vehicle while installing the supercharger system:

- Fuel Filter change
  - Engine oil and filter change using brand name oil (organic or synthetic) and filter
- Note:** It is **VERY IMPORTANT** to use the factory specified oil viscosity. The original equipment manufacturer has selected this grade of oil to work with your other engine systems such as hydraulic chain tensioner and variable cam controls. Deviation from this specification may cause these systems to fail or not function properly. Please refer to your owner’s manual for the recommended oil viscosity or your engine and application.

Non “Magnuson Superchargers Approved” calibrations or “tuning” will Void ALL warranties and CARB certification.

## Required Tools, Vehicle Prep and Consumables

- Small right-angle battery powered driver i.e. Milwaukee Model# 2457-20
- 14 EPL low profile socket (Torx Plus female) for under body fasteners. Snap-On # FLEPL140.
- Adjustable height cart (for coolant drain)
- 8mm ¼ drive swivel socket (for intake bolts)
- Coolant drain pan
- Used engine oil and coolant recycling containers
- Absorbent mat i.e. Pig mat
- China marker
- Constant tension clamp tool
- Fuel line disconnect tools
- Optional (if A/C lines will be disconnected): A/C discharge/recharge equipment for R1234YF refrigerant OR use local dealer/service center to evac + refill refrigerant.
- Snap-On crow foot adaptors FRDHM12, 13 and FRDHM15 (or longer)
- Snap-On 3/8 in. and ½ in. drive digital torque wrenches
- Stretch belt installation tool (EN-51767-1 Freedom Racing or similar)
- Black Tesa tape P/N 51036
- 3 1/8" diameter hole saw (coupe models only) for SC coolant fill reservoir installation
- JGR Billet Aluminum Jacking Lift Pads for Corvette (Amazon). Required to raise vehicle on 2-post hoist.
- Fixture to support power train removal and re-installation
- C8 vehicle frame to hoist locking adaptors (to lock vehicle to hoist). (2) C clamps for rear and 2 tie straps for front.
- Hydraulic jack
- C8 sub-frame to body alignment pins (to re-align rear sub-frame to body)
- Coolant system evac and fill kit (i.e. Snap-On SVTSRAD272A or OEMTOOLS 24444 Coolant System Refiller Kit)
- GM website access for torque specs.
- HP Tuners software for datalogging vehicle during dyno test

### **Project / Vehicle Prep:**

- Vehicle must have minimum 91 octane in the fuel tank prior to kit installation.
- Numerous factory hardware items are removed during installation of this kit. It is highly recommended to organize all items that are removed from the vehicle into labelled bags or containers.

### **Consumables:**

- AC Delco Dexcool 50/50 Premix Antifreeze (P/N 12378390) Approx. 8 gal. per vehicle required if power train is removed.

### **Contact Information:**

**Magnuson Superchargers**  
1990 Knoll Drive, Bldg A  
Ventura, CA 93003

**Sales/Technical Support Line: (805) 642-8833**

**Websites: [www.magnusonsuperchargers.com](http://www.magnusonsuperchargers.com)**

**Email: [sales@magnusonsuperchargers.com](mailto:sales@magnusonsuperchargers.com)**



# Table of Contents

|  |    |
|--|----|
| General Notes  | 2  |
| Required Tools, Vehicle Prep and Consumables               | 3  |
| Overview: HP Tuners ECM Unlock Procedure                   | 5  |
| ECM Verification Process                                   | 6  |
| ECM Unlock Process   | 6  |
| Section 1: Vehicle Teardown/ Powertrain Removal            | 10 |
| Section 2: Supercharger Installation / Vehicle Upfit       | 26 |
| Section 3: Charge Air Cooler Pump/ Electrical Upfit        | 74 |
| Section 4: Tunnel Reservoir Installation                   | 76 |
| Section 5: Coolant System Evac and Fill                    | 79 |
| Section 6: Flash ECM with Magnuson Calibration             | 79 |
| Section 7: Convertible Model Addendum                      | 82 |
| Appendix A: Hose Part # Matrix                             | 84 |
| Appendix B: Hose Routing Detail                            | 85 |
| Appendix C: ECM Removal                                    | 91 |
| Appendix D: Fastener Torque Specifications                 | 92 |
| Appendix E: Belt Routing Diagram for Provided K060722 Belt | 94 |
| Appendix F: Belt Routing Diagram for Optional K060710 Belt | 95 |
| Appendix G: Fill Reservoir Template                        | 96 |



## Overview: HP Tuners ECM Unlock Procedure

**IMPORTANT: Prior to beginning this process, you must take your vehicle to an authorized GM dealer and request that they update all vehicle modules with the latest software. Failure to have the latest updates installed on your modules may result in Loss of Communication trouble codes after your ECM has been unlocked and returned.**

Disconnect the battery (see step 18) then proceed to remove the ECM from the vehicle as shown in Appendix C at the back of this manual.

Your ECM will need to be sent to HP Tuners to be unlocked (see the next page). You will also purchase the appropriate number of credits for your vehicle application.

It is strongly recommended that you wait to install your supercharger kit until AFTER you have received your unlocked ECM back from HP Tuners.

When you receive the unlocked ECM back, install it into the vehicle, then start and drive the vehicle to ensure proper functionality of all vehicle systems in stock configuration. Verify that there are no DTC's present using the HP Tuners VCM Scanner software and your MPVI3 interface tool. Contact HP Tuners if there are any issues with the unlock process.

These steps are discussed in detail in subsequent slides.

You can then begin installation of your supercharger kit, request your new calibration file and use the HP Tuners MPVI3 cable and software to flash the Magnuson calibration to the vehicle. The file request process and flashing instructions will be covered in subsequent steps of this manual.

**IMPORTANT: You MUST flash a revised calibration file to the ECM after your supercharger has been installed. Severe engine damage could occur if you attempt to drive the vehicle on the factory calibration.**

## ECM Unlock Process

Go to the HP Tuners website and purchase the following 3 items:

- 1) appropriate unlock service for your specific application / model year vehicle.
- 2) MPVi3 OBD-II Interface.
- 3) HP Tuners MPVi credits (purchase the appropriate number for your specific application and model year).

Follow the HP Tuners instructions, carefully package your ECM and mail it to HP Tuners to be unlocked.

After you receive your unlocked ECM back, re-install it into the vehicle, re-connect the battery and perform the following steps using the HP Tuners VCM Scanner software and your MPVi3 interface.

**Note:** the HP Tuners VCM Suite software can be downloaded from the HP Tuners website. Install it onto your laptop.

### ECM Verification Process

1. Connect your HP Tuners MPVi3 interface to the OBDII port on your vehicle.

Connect the supplied USB cable between the MPVi3 and your laptop.



2. Open the HP Tuners VCM Scanner software on your laptop.

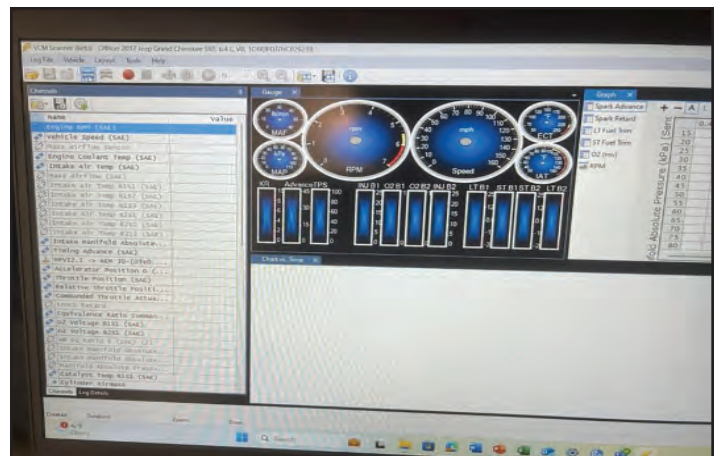

- 3. DO NOT press on your brake pedal.

Press and HOLD the start button on the dash until the instrument cluster powers up.



- 4. Using the HP Tuners VCM Scanner software, click the icon labelled Connect to Vehicle (see photo).

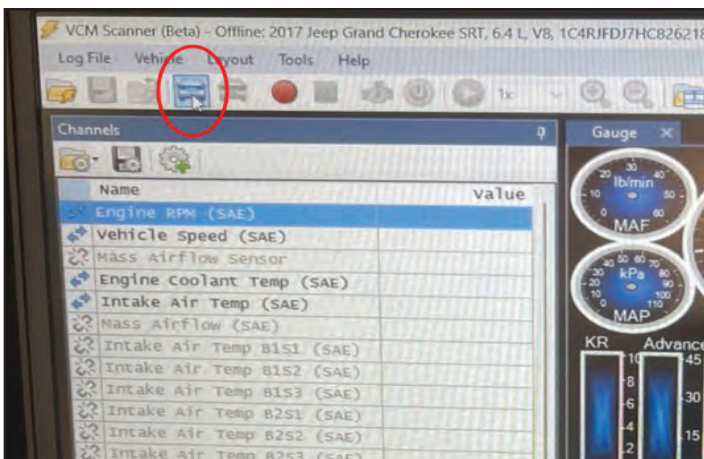

- 5. Click the Diagnostics and Information icon (circled).

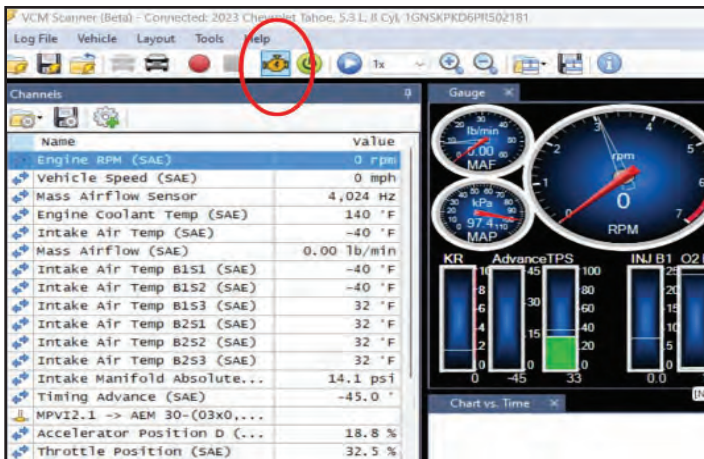

- 6. At the bottom left of the Diagnostics and Information window, click the Read DTC's button.

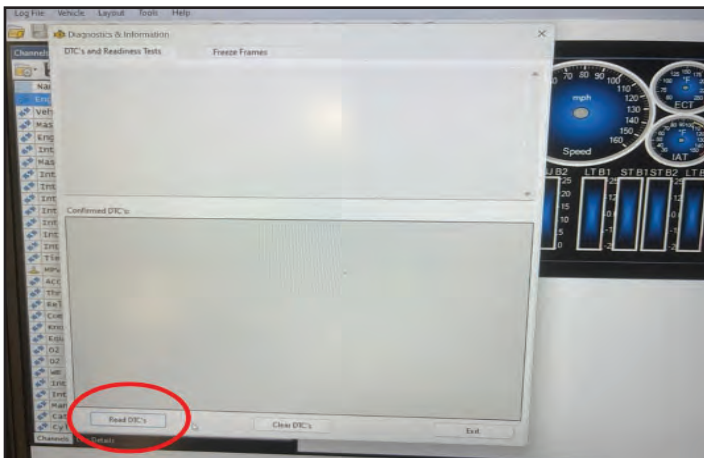



7. There may be a number of initial DTC's present. Take a screen shot or photo of the DTC's that show up in case they are needed for future reference.

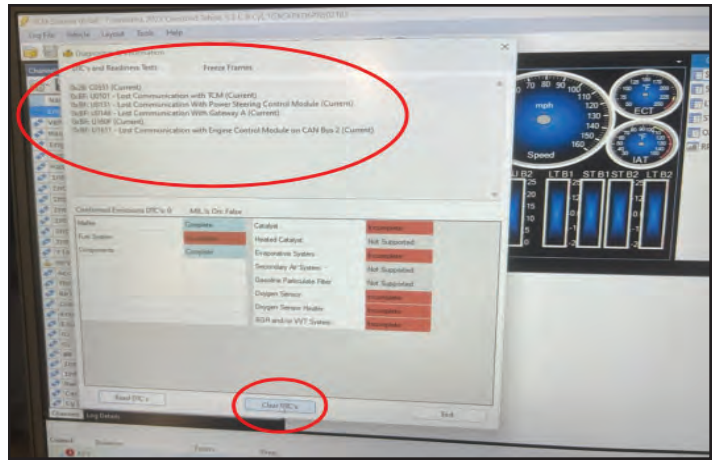

Now click the Clear DTC's button.

8. After all the trouble codes have cleared, click the exit button.

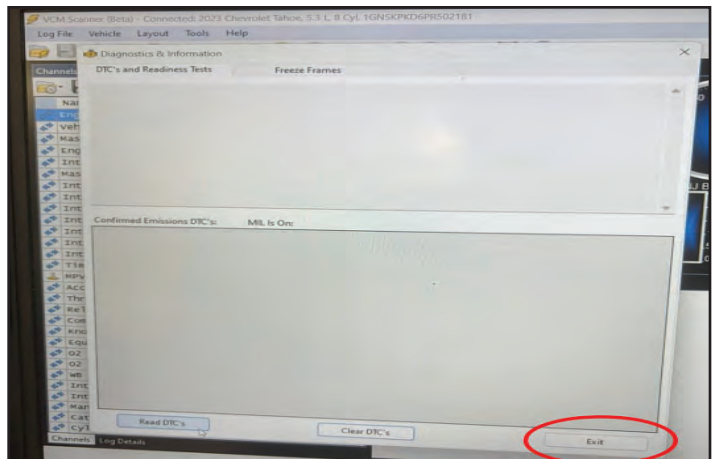

9. You can now start the vehicle. Perform three brief drive cycles, shutting the engine off and re-starting it between each cycle. This will ensure the unlocked ECM is functioning normally on the factory calibration. Re-verify there are no DTC's after the drive cycles.

Note that if you are data logging using HP Tuners you may see a warning on the dash for the vehicle anti-theft system. This is normal and will clear after the MPVI3 is disconnected from the OBDII port.

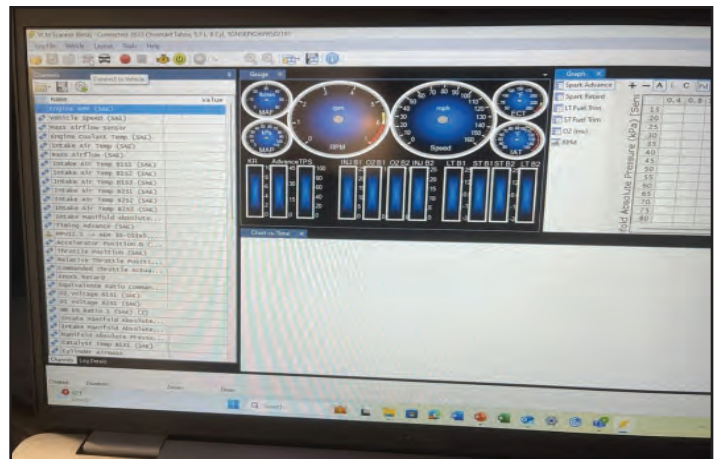

10. **Read the stock file from the ECM**

Open the HP Tuners **VCM Editor** software.

Do NOT press the brake pedal.

Press and HOLD the Start button until the instrument cluster illuminates.

Click on the Flash tab, then click Read Vehicle.

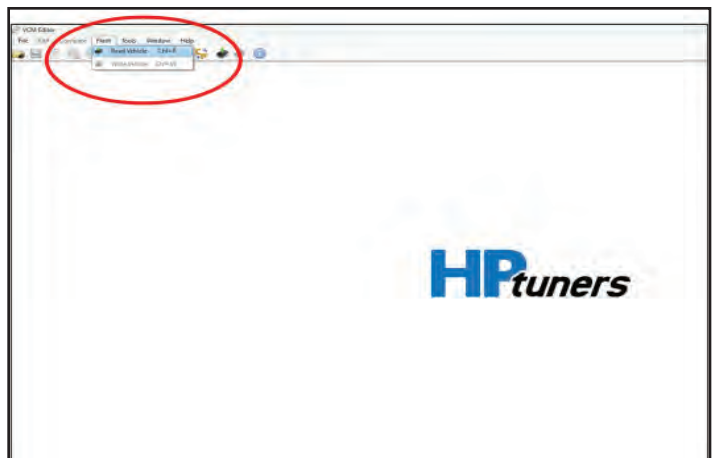

11. Follow the prompts as directed to read the stock cal file from the vehicle.

Have your VIN # available.

Save the stock cal file on your laptop with the following file naming convention.

Last\_8\_of\_VIN\_stock.HPT

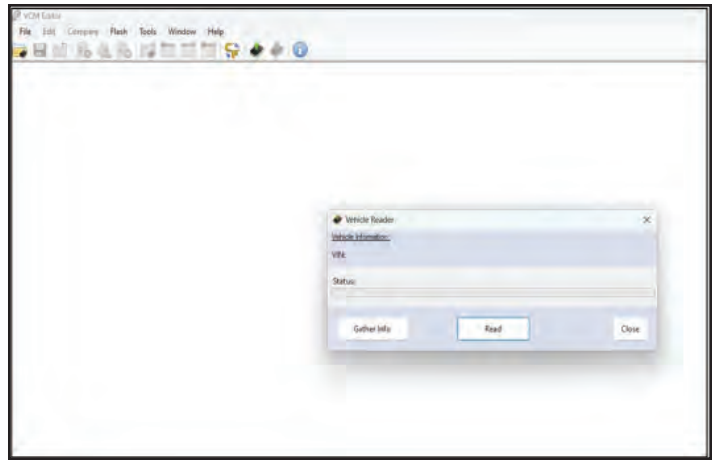

12. Click on the Info button (blue circled icon) at the top right of the tool bar.

When the VCM Suite Info window pops up, click on the Info button that is located in the pop-up window (red circled icon).

Hit the Save button (green circle). Save the Info file in the same folder as your cal file is located.

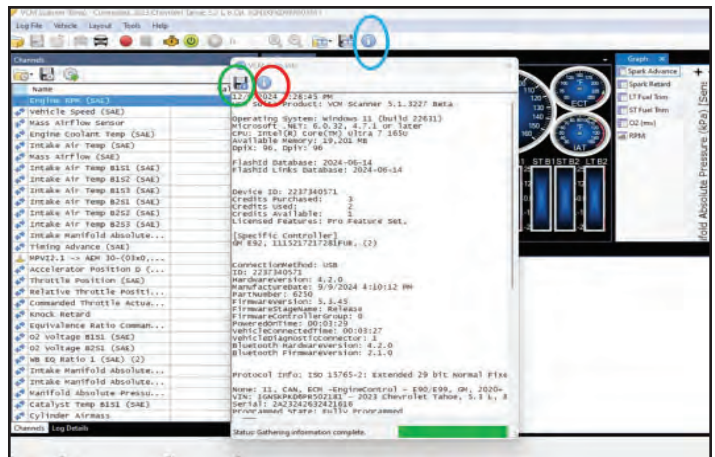

13. Go to the Magnuson website and locate your kit part #. At the bottom right of the webpage, click the link titled “Manuals, Documents and Calibration”.

Click the Global A/Global B Calibration Page.

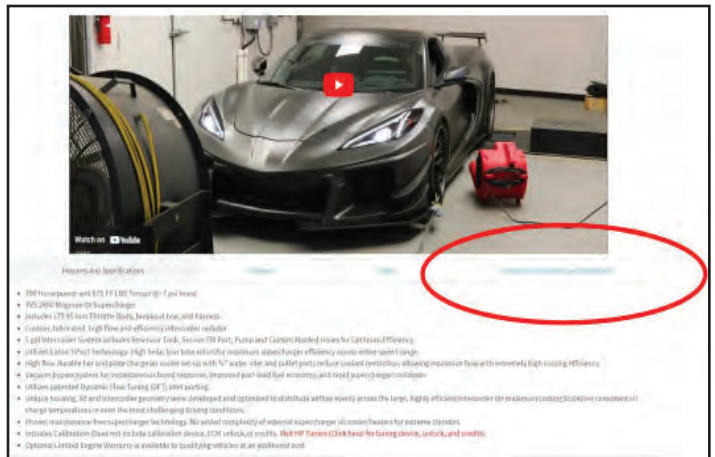

14. Click the Form link and enter the information requested, including your info file and your stock cal file.

You will receive an updated calibration file to the email address you provide in the form within 24 hours (excluding weekends and holidays).

Once you receive your new cal file, you can now proceed with installation of your supercharger kit, as detailed in the following steps.





Any reference to the left or right side of the vehicle is given from the driver's seat perspective.

## Section 1: Vehicle Teardown/ Powertrain Removal

15. **Before beginning the installation run a full tank of premium 91 octane or higher fuel through your engine. DO NOT USE E85 FUEL OR OCTANE BOOSTER! The vehicle must have premium fuel prior to starting the install.**



16. Prepare vehicle to be lifted on hoist.

Only raise the vehicle via factory lift locations using the proper lift pucks (noted at the beginning of this manual).

Secure the vehicle to the hoist using ratchet straps and clamps @ LH / RH rear as required.

Remove the rear wheels.



17. **For C8 Convertible applications:** Turn on accessory power by holding start button for several seconds until the dash powers up, then raise the convertible top to allow access to the engine.



18. Raise hood and trunk **BEFORE** disconnecting negative battery cable from battery.

After battery cable has been removed, place a rag between the cable and the terminal to ensure they do not accidentally contact each other.





19. Inside trunk, remove carpet from trunk then remove fasteners from perimeter of front closure panel.

Remove front closure panel and set aside.

Place all fasteners in an identified bag.



20. Working from under the vehicle, remove (4) under body panels in the center of chassis, in the order shown in the photo.

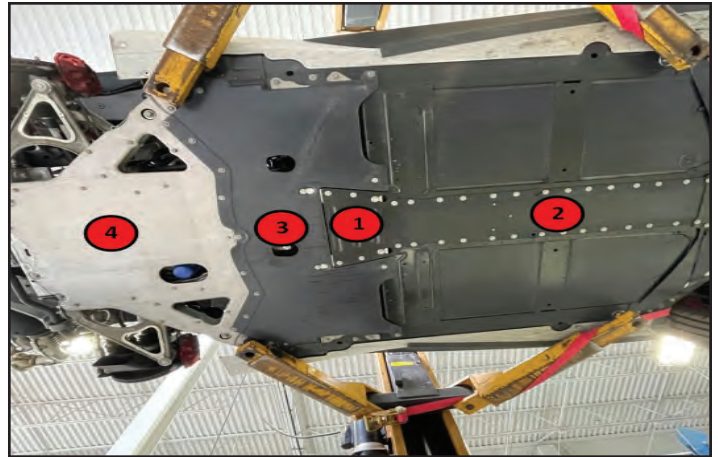

21. Remove rear lower under body valence and rear brake cooling ducts, if installed.

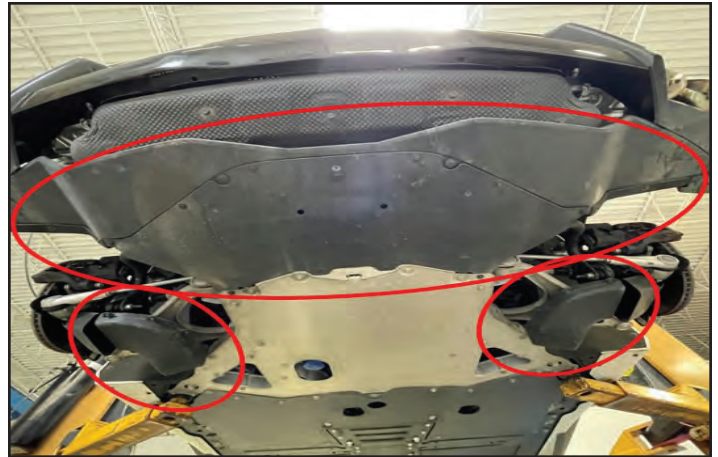

22. Remove the long rectangular composite center cover plate.



## 23. Remove rear plastic exhaust cover.



## 24. If your vehicle has a tunnel-mounted ECM, see Appendix C at the back of this manual for removal instructions.

Remove the ECM support bracket from the vehicle.

On later model vehicles, the ECM is located behind the LH rear wheel (Shown in the next step).

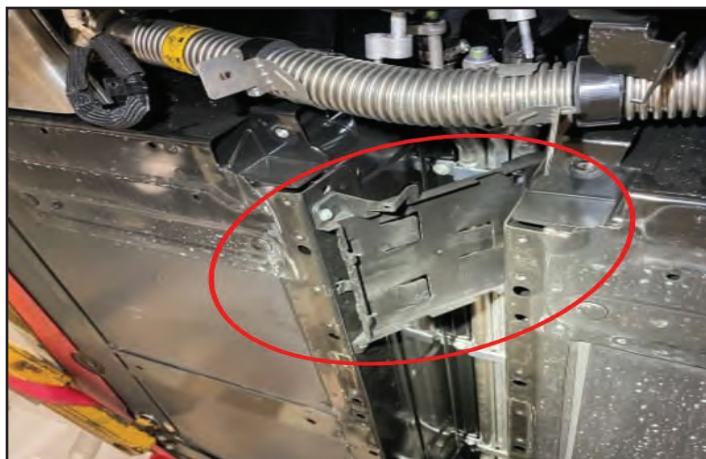

## 25. Remove LH / RH rear inner fender panels using a Torx T15 socket for screws and forked trim removal tool for plugs.

Pull plastic rock guards off LH / RH rear corners of wheel wells (bottom right photo).

If your vehicle has LH rear mounted ECM, you will now have access to remove it. See Appendix C at the back of this manual for removal instructions.

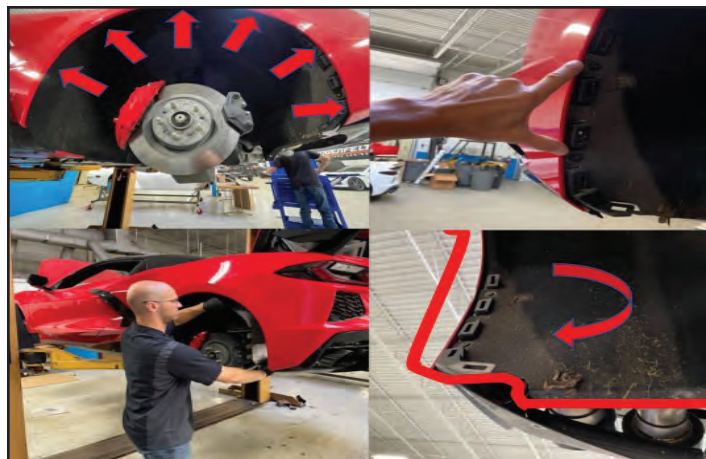

## 26. Prepare to remove the rear fascia.

Facing rearward from inside each rear fender, locate and remove the fasteners attaching the rear fascia to the LH / RH fenders @ rear upper corners.





27. Remove fasteners around perimeter of rear upper valance.

Note quantity of shims that are located between rear valance and body structure at each location. A grease pencil can be used to identify the quantity by each screw hole.

Remove all shims and place in an identified bag.



28. Remove fasteners in upper LH / RH corners securing rear valance to rear fenders.



29. With help from a second person, gently lift and begin to separate rear fascia from vehicle.

Disconnect (3) electrical connectors between body and rear fascia.

Set the rear fascia aside on a soft, clean surface to avoid scratches.



30. Remove the beauty covers (if installed).

If you are removing the power train, the OE black torx bolts will be replaced with new bolts in the following slide.

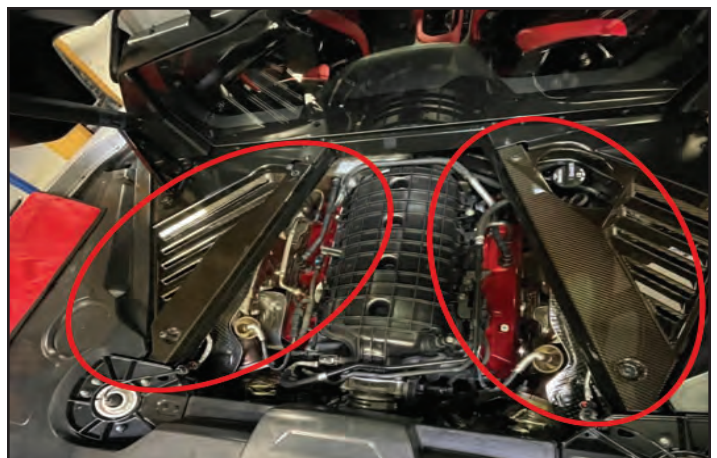



31. Install revised M8X1.25-60mm long flanged fasteners from the kit P/N 71-08-12-060 (8 places).

**Torque the fasteners 22 ft-lbs.**



32. Loosen LH / RH air inlet ducts (4 fasteners per side) and remove from vehicle.

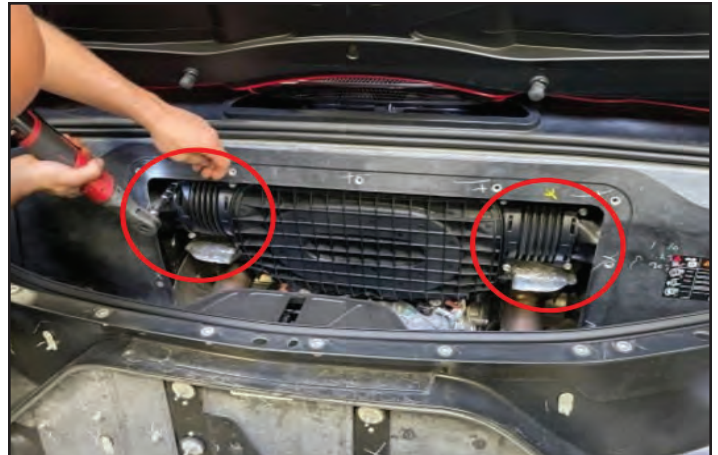

33. Disconnect the vapor purge line connection @ RH side of engine.

Remove purge line clip fastened to the body brace.



34. Lower the vehicle to provide access into the engine compartment.

Remove upper shock mount nuts (3 per side) from LH / RH sides.

Disconnect mag ride sensors from bracket then disconnect hard shell connector (LH / RH sides).



35. If equipped with mag ride, zip tie LH / RH mag ride pig tail harnesses back onto themselves so they won't catch on the shock tower during power train removal.

Trim zip-ties.



36. **Convertible Only:** Remove fasteners around the perimeter of the engine access cover.

With a helper, remove the cover and set aside.



37. Remove the radiator cap from the reservoir and set it aside.



38. Remove any fasteners holding the brake line brackets and heat shields from the LH and RH aluminum frame braces by the fuel cross-over.

Remove LH and RH frame braces from the vehicle.

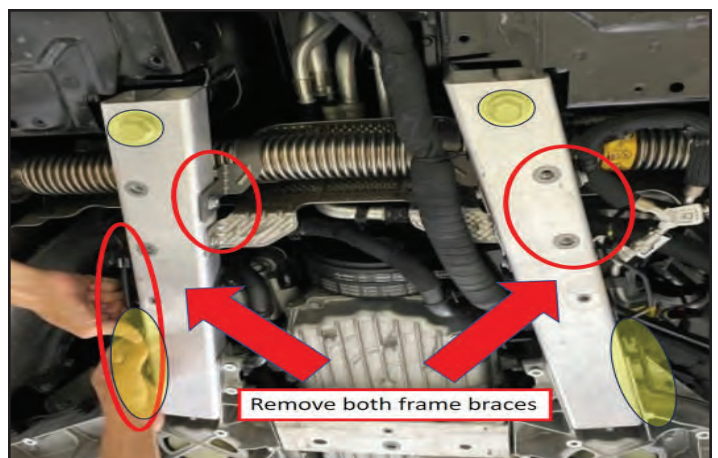



39. Disconnect LH and RH brake lines from plastic holders at cradle.



40. Remove (4) push pins securing the fuel cross-over heat shield. Remove the heat shield from the vehicle.

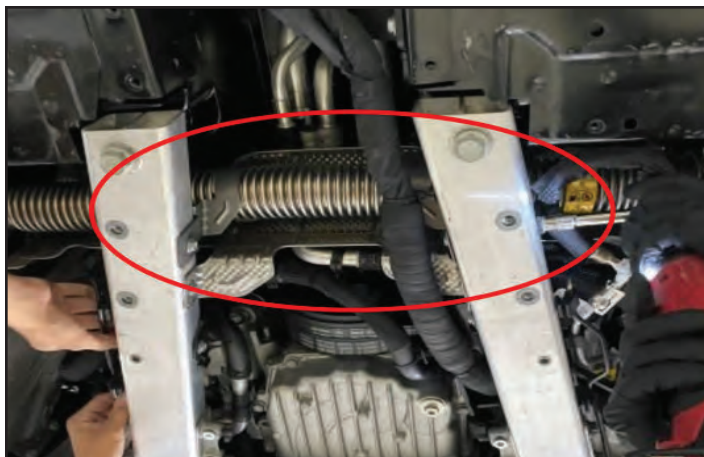

41. Disconnect exhaust valve connectors near exhaust pipes. (LH/ RH sides).



42. Disconnect rubber exhaust hangers from LH / RH sides.

LH / RH just before exhaust valves and LH /RH after exhaust valves (Remove bracket fasteners).





43. Remove fasteners securing the LH and RH rear exhaust hanger brackets to the body.

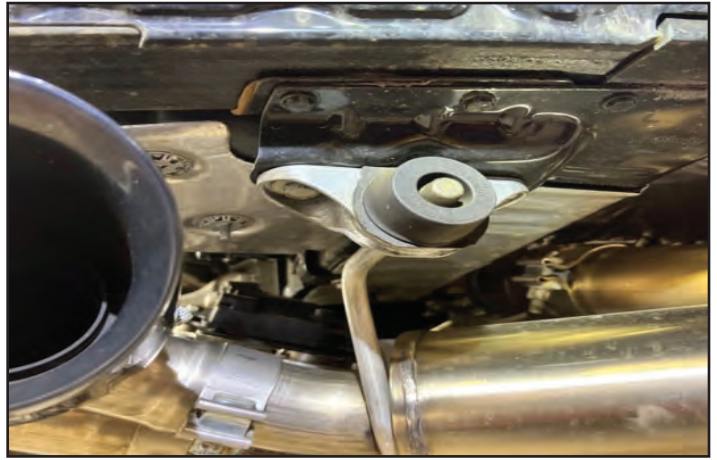

44. Remove Trans Control Module (TCM) by removing (4) bracket bolts.

Disconnect (2) electrical connectors @ TCM.

Set TCM aside.



45. Remove wiring harness fir tree connectors from plastic TCM bracket.

Remove fasteners securing TCM bracket to vehicle then remove bracket and set aside.



46. Place a large, clean container on a stand to minimize coolant loss.

Install a 3/8" I.D. rubber hose onto the drain tube. Place a rag under the drain then loosen the coolant drain @ bottom of radiator and allow coolant to drain in a bucket.

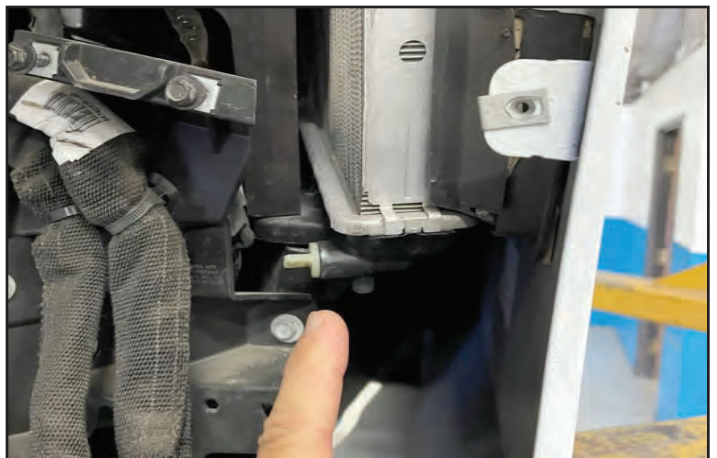

47. Remove (3) tunnel tube brackets from top of tunnel.

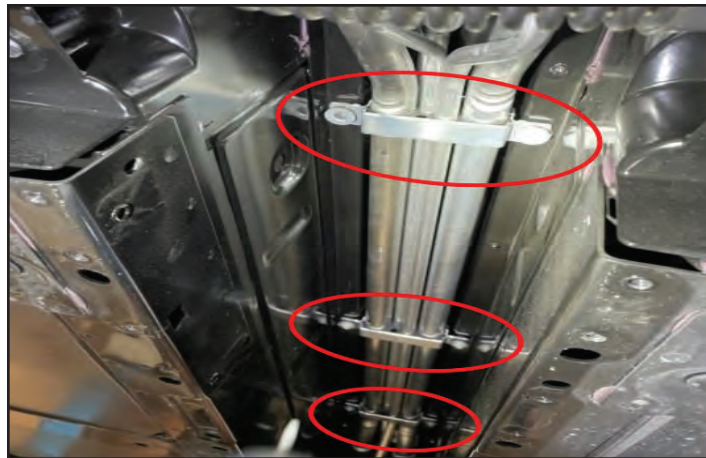

48. There are two options for the A/C system:  
 If the A/C compressor will be left attached to the engine, the A/C system must be evacuated, and the lines disconnected at the location shown.  
 Loosen and remove (2) AC tube connection nuts above the fuel crossover tube and separate the two lines.  
 Alternatively, the A/C lines can be left connected, the compressor can be removed from the engine and hung from the chassis, just prior to removal of the powertrain from the vehicle. This will be covered in a subsequent step.

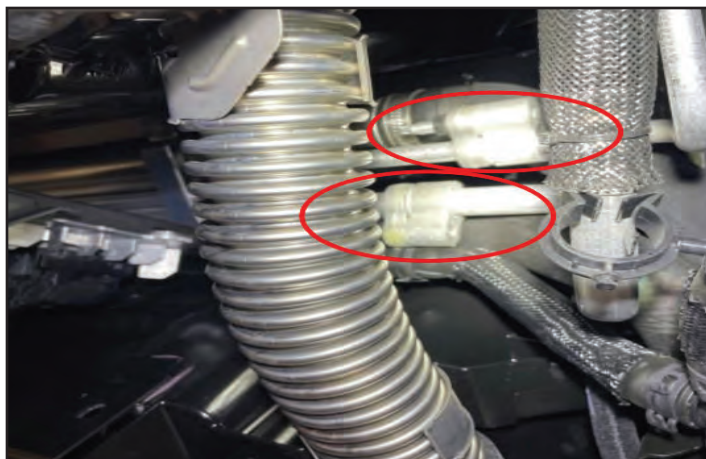

49. Disconnect rubber hose from small aluminum tube.

\* Prepare for additional coolant loss \*



50. Loosen (1) gear clamp and (1) constant tension clamp from main coolant tube connections. Remove coolant hoses from tubes.

\* Prepare for additional coolant loss \*

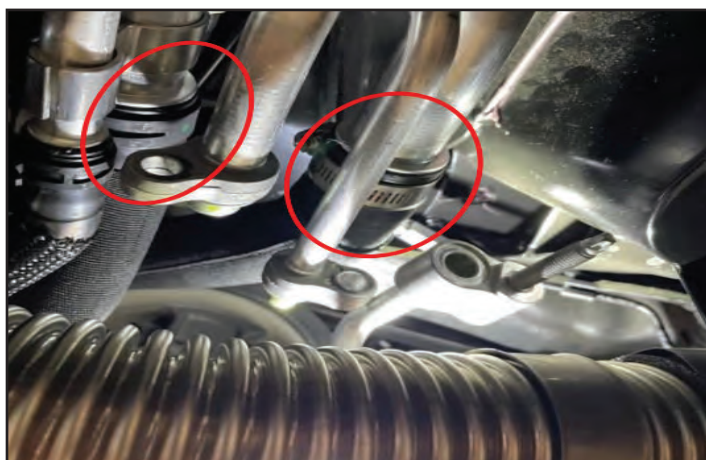



51. Place a large, clean container on a stand to minimize coolant loss.

Continue to drain the engine coolant by disconnecting the rubber coolant hose at the lower aluminum tube below the alternator.

After all coolant has drained, re-connect the hose and fasten with the original constant tension clamp.



52. **\*\* VERIFY BATTERY IS DISCONNECTED BEFORE PROCEEDING WITH THIS STEP \*\***

Inside RH rear wheel well, remove the positive battery cable cover from alternator.

Loosen and remove (2) nuts securing positive battery cable to the alternator.



53. Disconnect B+ fir tree connector from the bracket by the alternator.



54. Disconnect fuel line at LH side by tunnel.

Plug fuel line connectors with fuel-safe plugs to avoid contamination/leakage.





55. Remove brake line bracket fasteners on LH / RH control arms.

Remove brake line bracket fasteners inboard of LH / RH lower control arms @ sub-frame.



56. Disconnect LH / RH wheel speed sensors and mag ride sensors at hardshell connectors by inboard bracket.

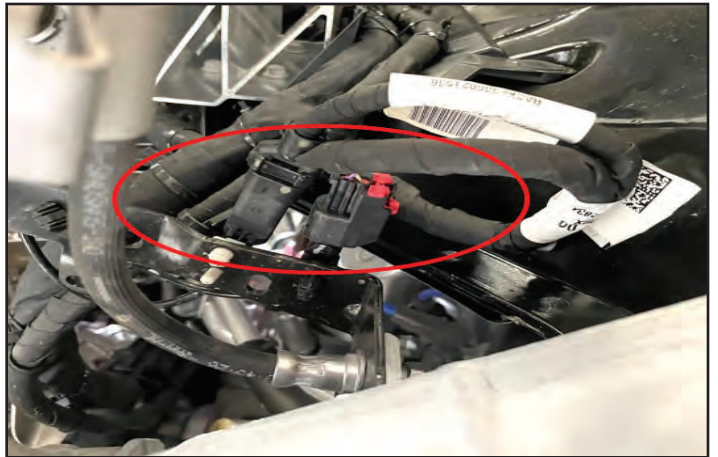

57. Disconnect LH / RH wheel speed sensor and mag ride harness fir tree connectors from inboard bracket.

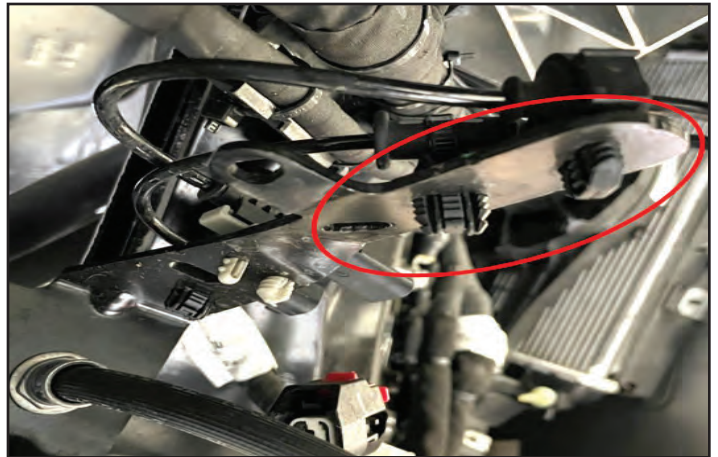

58. Inside RH rear wheel well, remove fastener securing chassis cable ground (highlighted in red).

Remove plastic harness bracket securing ground cable to chassis.



59. Inside RH rear fender: Remove hardshell connector from thermostat sensor.



60. Disconnect (2) coolant lines at bulkhead connection @ RH rear of car. Note there is a thermostat inside one connection. Disconnect inboard of this connection.

Note: coupe version will have (4) connections inside RH rear fender (1 is located at the bottle, 1 is a coolant vent).

Coupe: remove (1) fir tree connector @ bracket ( blue inset photo).

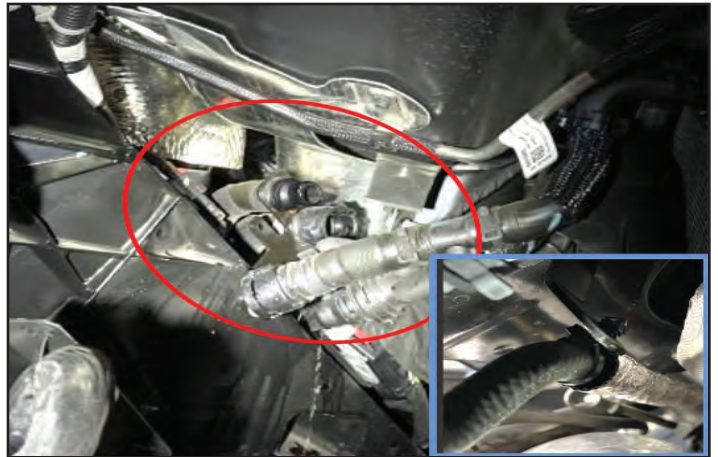

61. Remove LH / RH rear calipers from rear suspension.

Wrap in a towel and slide the calipers inside the base of LH / RH rear fenders.



62. Disconnect (2) bulkhead connectors inside LH rear wheel well.





63. LH side: Remove (2) fir tree connectors holding plastic harness bracket to frame.

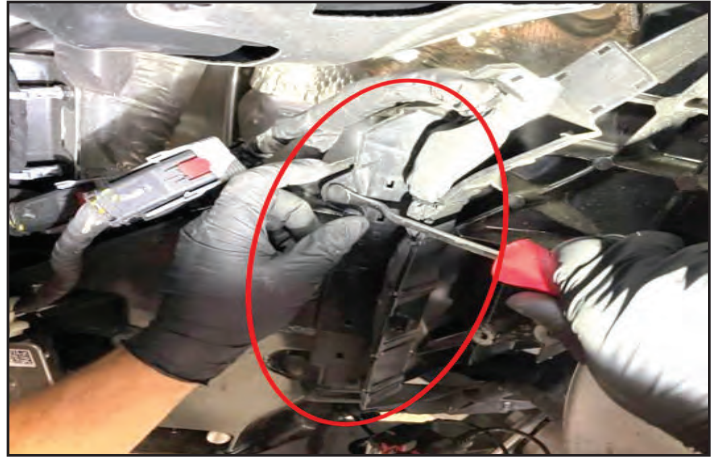

64. Disconnect LH / RH wheel speed sensor and accelerometer (if equipped) pigtails at connection points in front of the rear calipers.



65. Remove FTZM module from LH fender by removing all bracket fasteners.

Disconnect electrical connector from module. Set module aside.

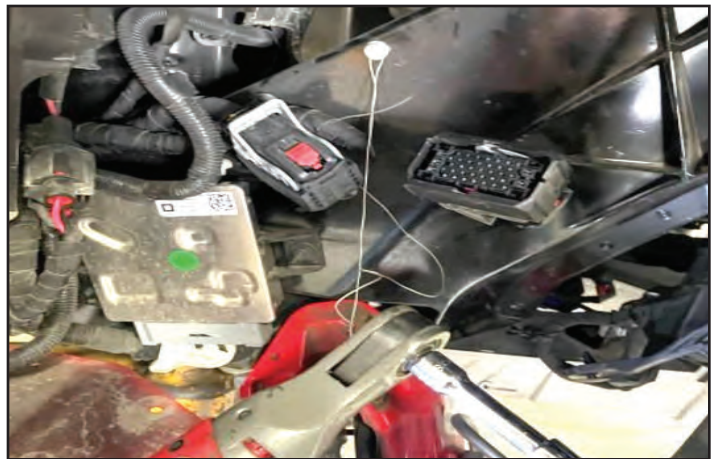

66. Disconnect LH / RH parking brake harnesses (highlighted in red) from chassis retention points.

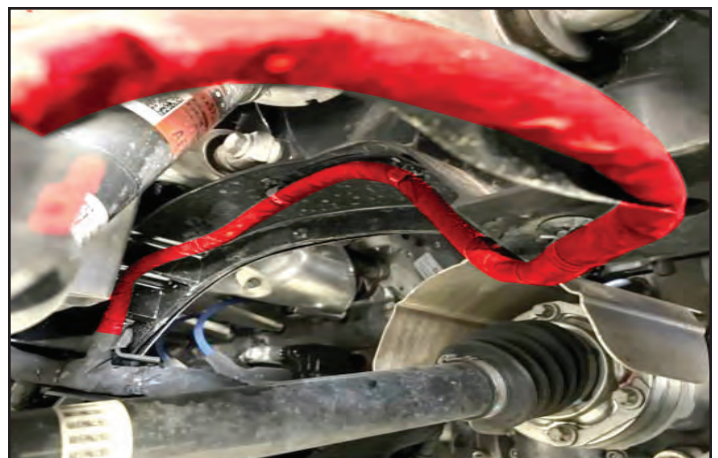



67. Remove LH / RH crash blocks in front of upper control arms.

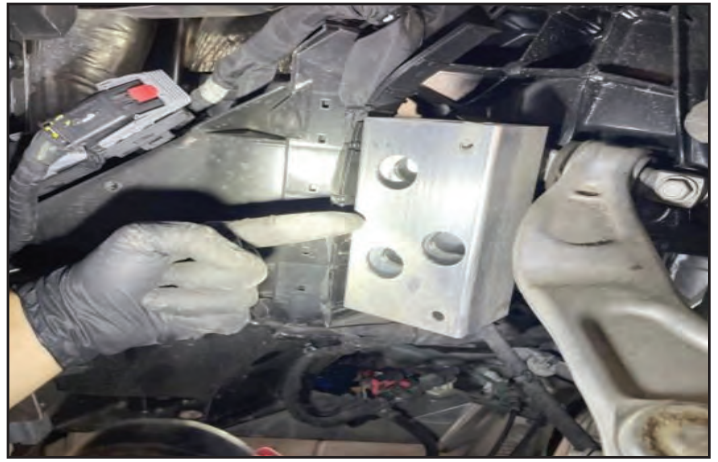

68. Inside the right rear wheel well, fir tree connectors secure the main harness bundle to a bracket, the frame structure and the coolant line bracket. Use a forked removal tool to remove the harness from these points.

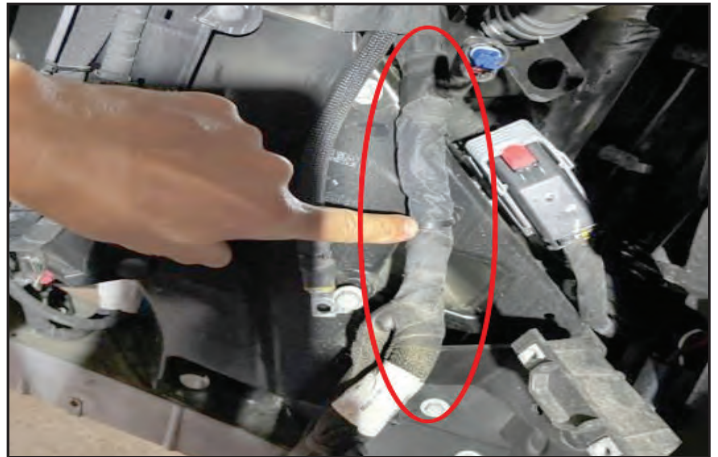

69. Remove (1) fastener @ coolant line bracket.

Tuck coolant lines inside frame so they won't catch during power train removal.



70. Disconnect NPP exhaust valve connectors @ LH / RH valves if vehicle is equipped.

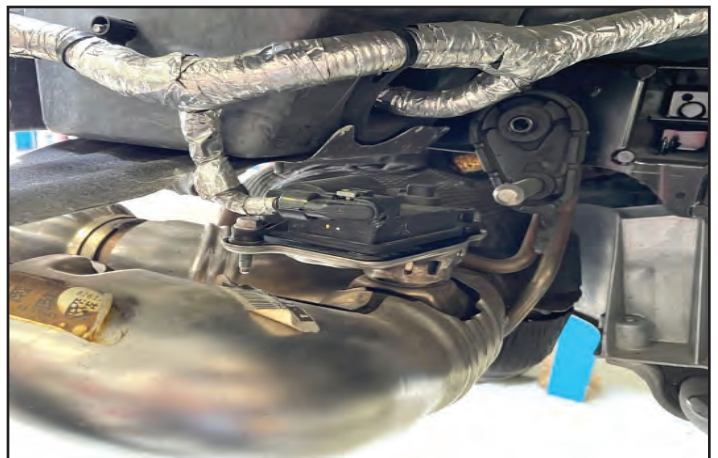

71. **Convertible Only:** Inside RH side of engine bay, disconnect (2) coolant fittings.



72. **Convertible Only:** Remove (2) nuts securing fuel line above RH exhaust manifold.



73. Remove LH / RH upper control arm bolts (4 per side).

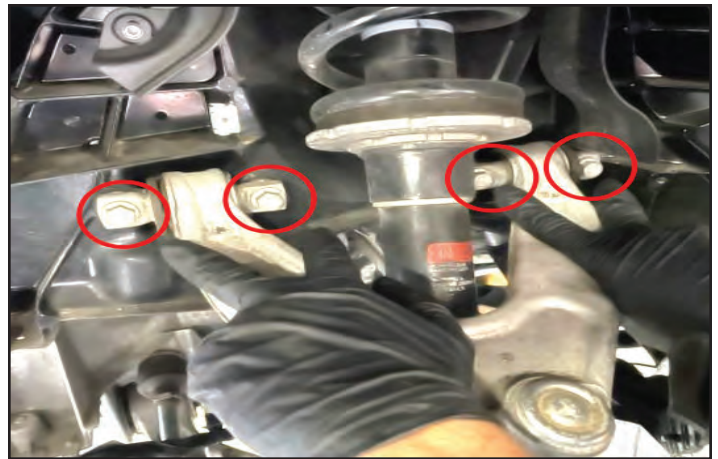

74. Raise the vehicle. Prepare for power train removal.

Fabricate a suitable power train removal fixture and secure it to the vehicle sub-frame.





75. Install C-clamps @ LH / RH rear hoist lift points to secure vehicle to hoist.



76. Roll the lower fixture under the vehicle, aligning (4) posts over the upper fixture.

Lower vehicle to engage posts into upper fixture. Fully seat posts into holes.

Tighten (8) jack screws at all post locations.

Lower vehicle to pre-load the weight of the power train onto the fixture.



77. Remove (4) main body structure bolts.

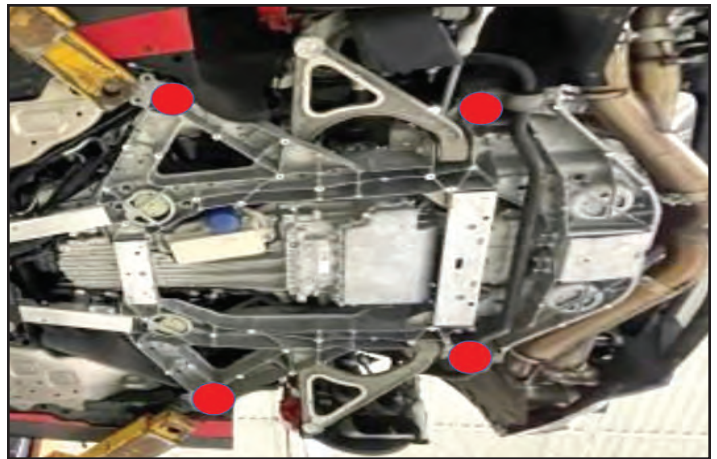

78. **SLOWLY** raise vehicle on hoist. Using helpers, carefully inspect for any remaining coolant, fuel or wiring harness connection issues and/or snags as the vehicle is raised.

**Note:** If removing A/C compressor from the engine, raise the vehicle approx. 6 inches from the power train then cut the A/C compressor belt. Unplug the A/C compressor electrical connector then remove the compressor from the engine.

Hang the A/C compressor securely from the under body. Continue raising the vehicle until the powertrain has cleared the body.





79. Carefully roll power train out from under vehicle. Use wheel locks as necessary to ensure it remains secure.



## Section 2: Supercharger Installation / Vehicle Upfit

80. Remove the airbox.

Remove (2) fasteners @ bottom rear, (1) sensor @ bottom rear, (2) wiring harness fir tree connectors @ bottom corners.

Loosen the gear clamp securing the airbox to the clean air tube at the front.

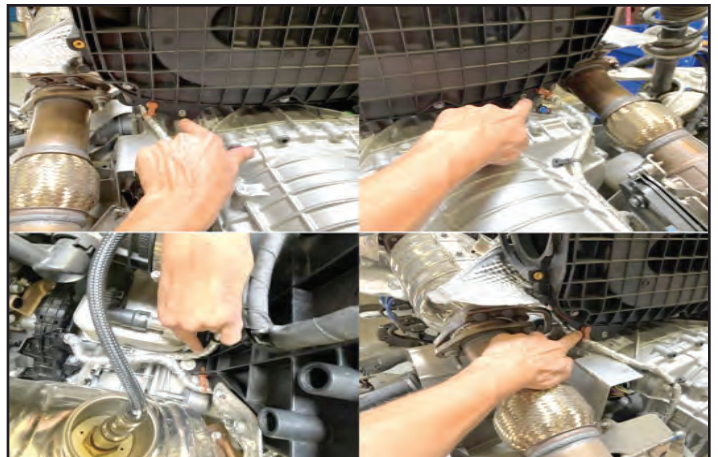

81. Disconnect trans breather vent fir tree connector from airbox.



82. Disconnect oxygen sensor fir tree connectors and takeouts from front of airbox.





83. Loosen the gear clamp at the front of the clean air tube to throttle body joint.

Disconnect the PCV tube from adaptor.

Remove the clean air tube from the throttle body..

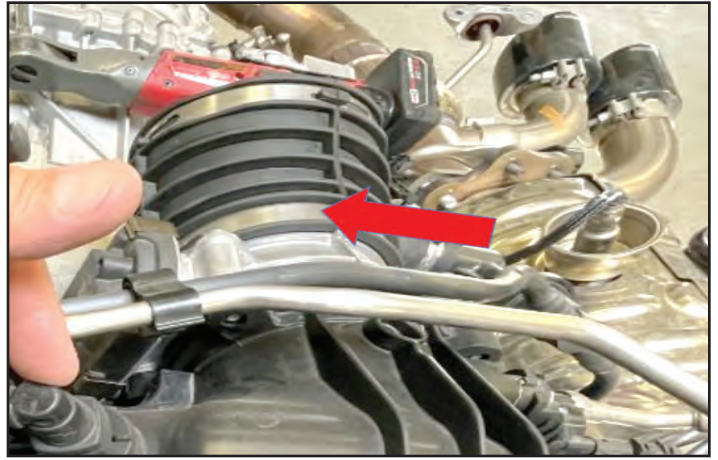

84. Remove the entire Purge and PCV tube assemblies from the engine.

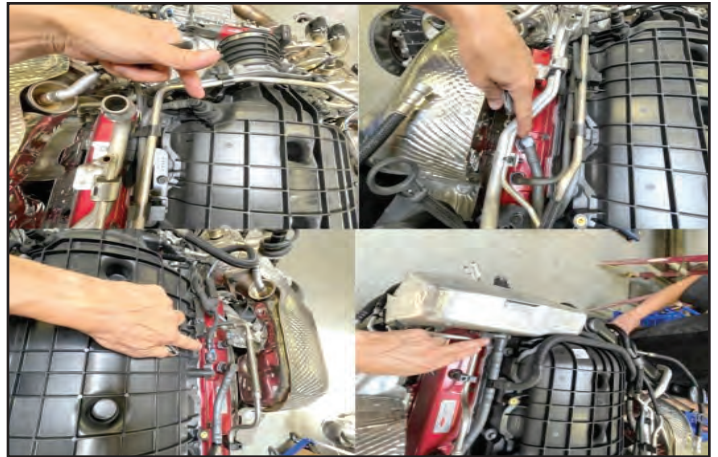

85. Disconnect oxygen sensor fir tree connectors then disconnect oxygen sensors at hardshell connectors.



86. Disconnect ETB electrical connector on RH side of throttle body.



87. Remove purge solenoid from the intake.

The solenoid and its' OE fastener will be re-installed to the inlet adaptor on the supercharger in a later step.

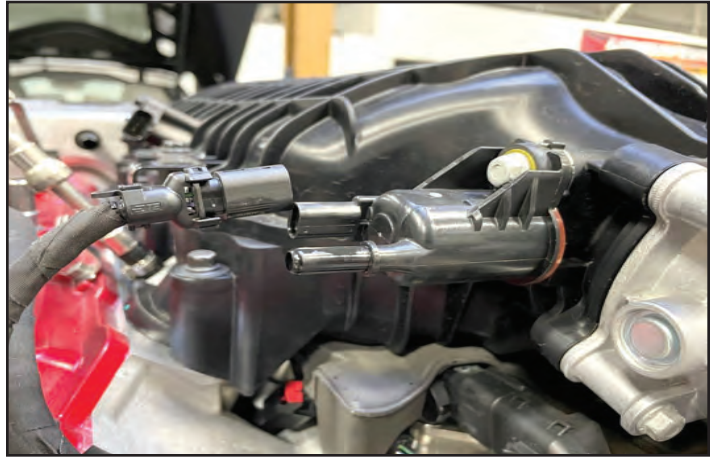

88. Remove the evap purge solenoid from the evap line using a spring lock tool.



89. Disconnect harnesses @ hardshell connectors and remove wiring harness bracket @ RH front of engine.



90. Loosen and remove all intake fasteners.

Remove intake from engine.

Wipe down and tape all intake ports to ensure no contaminants enter the engine.

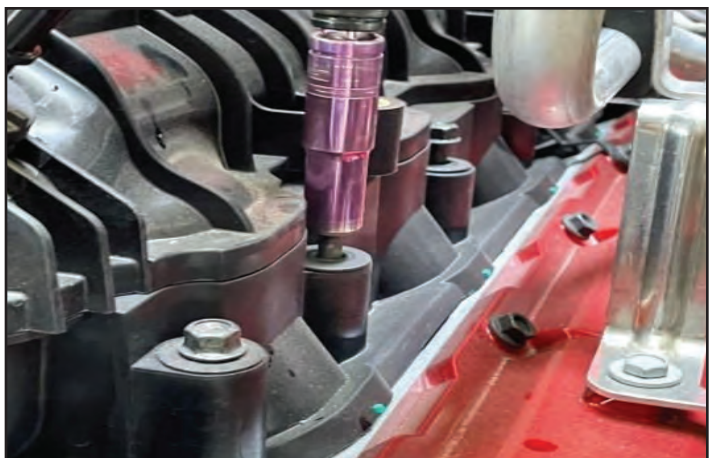



91. Remove the NVH foam blanket from engine valley.

Clean the intake ports with a clean rag and brake kleen.

Tape off the ports to prevent contamination from entering the engine.

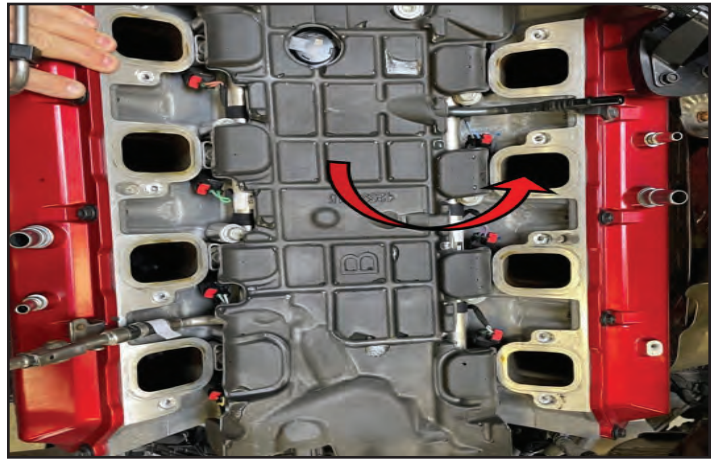

92. **If valve springs are being upgraded**, follow the procedure detailed in the GM C8 service manual to remove and re-install the springs.

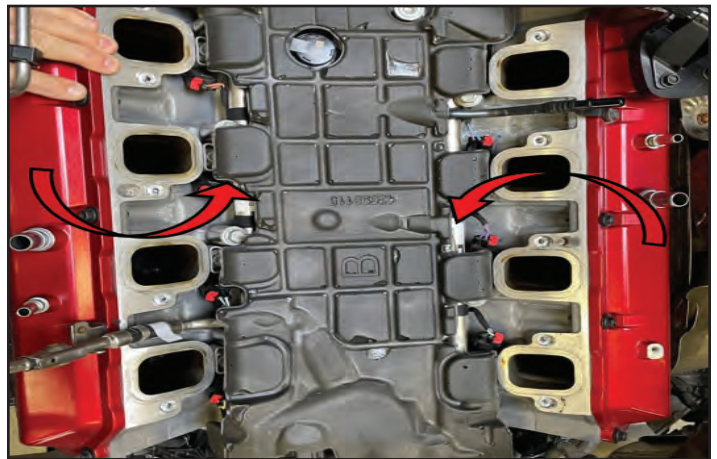

93. Remove 2 fir tree connectors holding coolant degas tube to oil fill tube.  
Remove the bolts securing the dipstick and oil fill tube.  
Remove the dipstick and oil fill tube.  
Harvest the seal from the oil fill tube @ dry sump side as indicated in the bottom photo.  
Set the seal aside.  
The factory oil fill tube and cap will not be re-used.



94. Harvest (8) seals from OE intake ports.

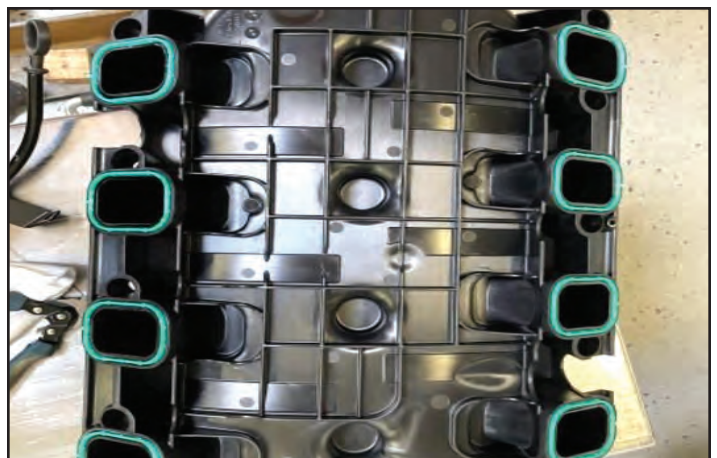



95. Re-install (8) OE PIP gaskets into SC head unit.

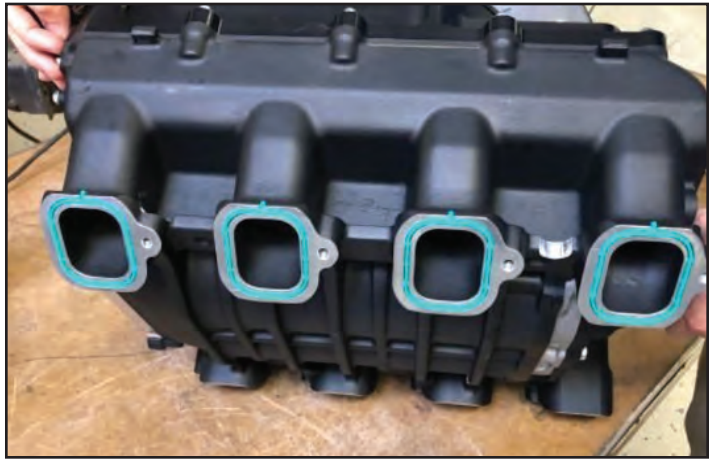

96. Smear di-electric grease around perimeter of (8) intake ports.

Rotate fuel line lock in valley by DI pump so it faces horizontally.

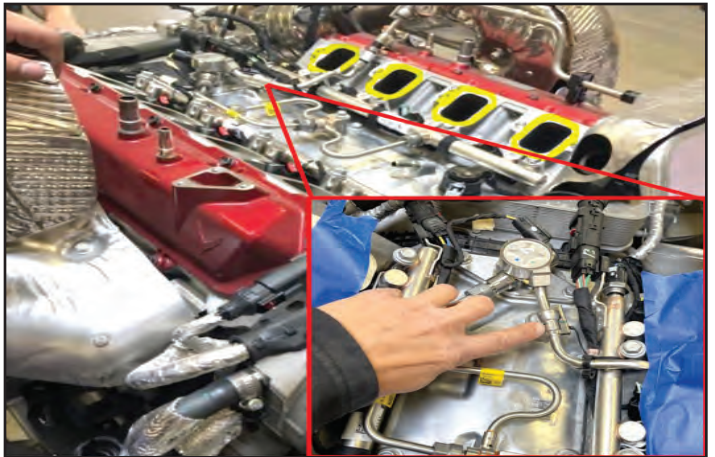

97. With the aid of a helper, install the supercharger head unit onto the engine.

Ensure the intake gaskets do not roll or become displaced during installation.



98. Apply blue Loctite 242 then install (8) intake bolts P/N 71-06-10-035 through the intake into cylinder heads.

Zero torque all bolts starting from the center out, in a criss-cross pattern.

Ensure the intake seats uniformly against both heads as the gaskets compress.

**Pre-torque (8) intake bolts to 71 in-lbs in sequence.**

**Final torque (8) intake bolts to 106 in-lbs. in sequence.**

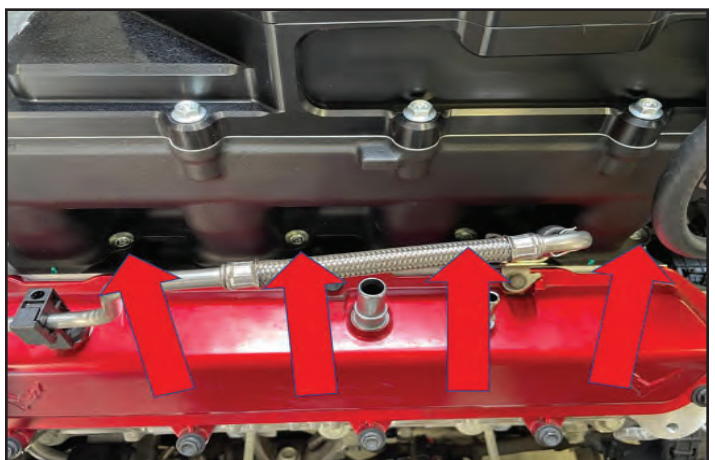



## 99. Install revised NGK LTR7IX-11 spark plugs.

Gap to 0.032 – 0.035 inch. **Torque spark plugs to 15 ft-lbs.**



## 100. Remove (2) radiator hoses from engine.

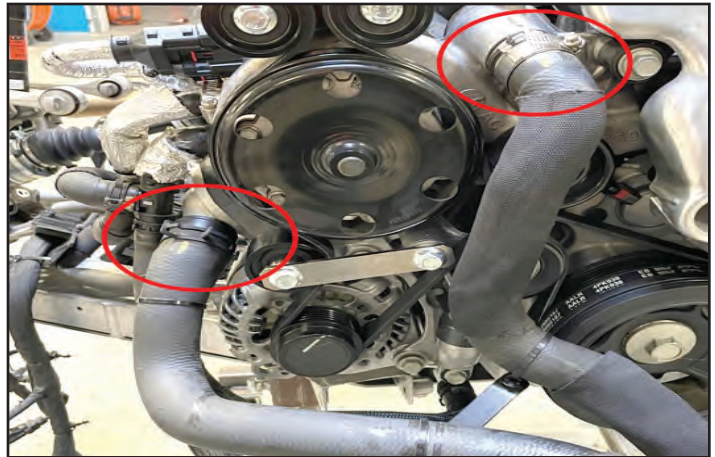

## 101. Remove serpentine belt from engine by gently rotating the hydraulic tensioner via the pulley bolt. Rotate clockwise to release tension.

102. **FEAD Drive Installation**

Pre-install (1) P/N 71-10-15-025 fastener into RH front cylinder head in the location shown.

**Note:** Due to water pump casting variance, the bolt may have to be ground slightly shorter to allow engagement into the cylinder head threads.



### 103. 2-Piece Jackshaft Installation

Slip the jackshaft lower bracket PN 65-26-62-079 onto the bolt that was pre-installed in the previous step.

Orient and align the lower bracket with the holes in the RH cylinder head.

Install (2) M8 X 30mm long bolts through the lower bracket into the cylinder head. After all (3) fasteners have been installed by hand, shift the lower bracket toward the drivers' side of the engine, hold in place, then torque the fasteners.

Note: a crow foot wrench may be required.

**Tighten M8 bolts to 21 ft-lbs.**

**Tighten M10 bolt to 41 ft-lbs.**

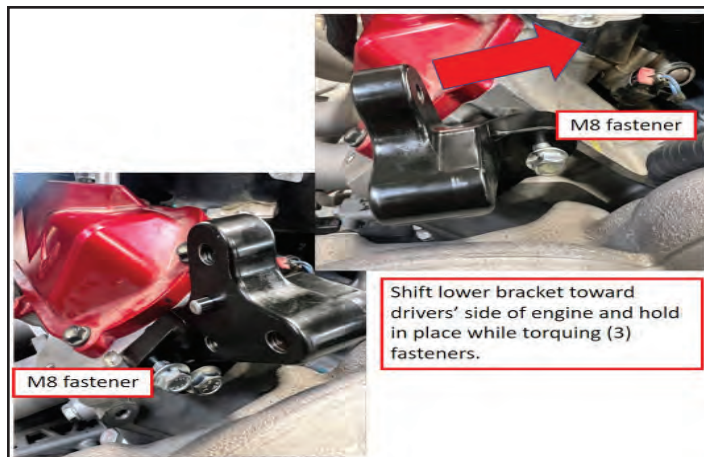

104. Disconnect and route the factory wiring/hard shell connectors between the lower bracket and the back of the water pump as shown.

Re-connect the wires and slide the locking tabs in place.

Zip tie the wires away from the exhaust system as necessary.



105. Select the upper jackshaft bracket assembly P/N 31-26-62-081.





106. Sub-assemble the following items to the upper bracket:

Pre-install coolant hose 087F through the hole in the middle of the upper bracket, in the orientation shown.

Sub-assemble (2) P/N 56-06-01-054 idler pulleys onto the upper bracket bosses.

Apply blue Loctite 242 to (2) M10 X 35mm long idler pulley fasteners P/N 71-10-15-035.

**Torque the fasteners to 41 ft-lbs.**

Install drive pulley P/N 57-00-06-130-BL to the jackshaft hub on the same side as the idlers.

Apply blue Loctite 242 to (4) M6 X 12mm long bolts P/N 71-06-10-012. **Install the bolts and torque them to 106 in-lbs in a criss-cross pattern.**

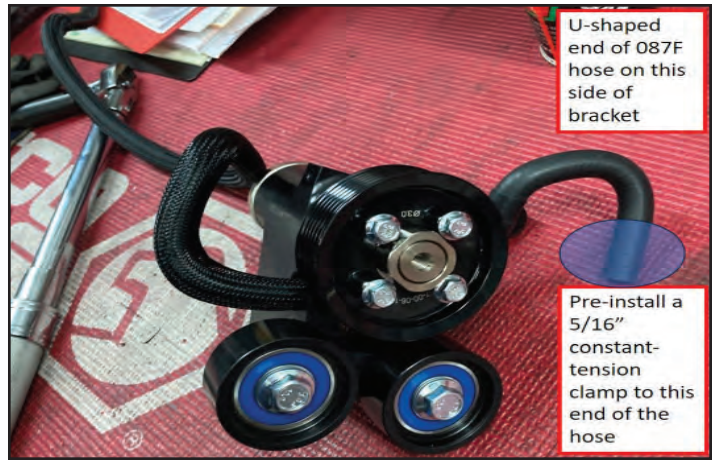

107. Install the upper jackshaft sub-assembly onto the lower bracket, aligning the dowel pin(s) and the 3 holes.

Apply blue Loctite 242 and install (3) M8 X 30mm long fasteners through the upper jackshaft bracket. Ensure the dowel(s) engage the bracket and the two halves fully seat against each other as the bolts are tightened.

**Torque the (3) fasteners to 21 ft-lbs.**



108. **Static tensioner installation:**

The static tensioner is installed to the rear of the upper bracket using (2) M10 X 35 mm long socket head cap screws, PN 72-00-10-036 and (2) 10mm ID washers from the kit. Install the washers onto the fasteners then apply blue Loctite 242 to the fasteners.

**Install and torque to 41 ft-lbs.**



109. Select the M8 X 25mm long set screw, apply blue Loctite 242 and pre-install it only a couple of turns, into the billet tensioner as shown.

The static tensioner pulley is secured to the billet bracket using a slide nut P/N 77-10-15-010, idler post P/N 69-90-47-008 and idler P/N 56-30-01-062-BL





110. Select the idler post P/N 69-90-47-008 and idler P/N 56-30-01-062-BL.

Install the post onto the idler as shown.



111. Select the tensioner slide nut PN 77-10-15-010 and prepare to install it into the bracket in the orientation shown.

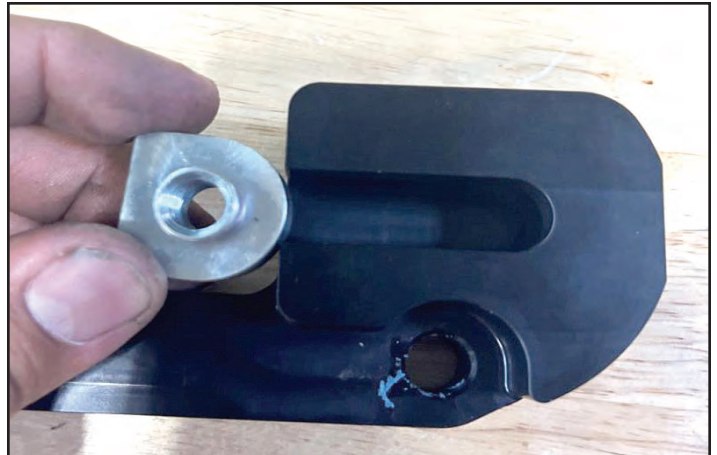

112. Select the M10-1.5 X 45mm long fastener from the kit. Apply blue Loctite 242 to the threads.

While holding the slide nut in place, hand-start the fastener through the idler and into the slide nut.

Slide the idler to the top of its' travel in the bracket to allow for sufficient clearance to install the cog belt. Snug the bolt to keep the idler in place. This will provide for the most belt clearance.



113. Verify the 30T cogged pulley is installed to the rear of jackshaft. If installation is required, apply blue Loctite 242 and install/torque M6 X 16mm long bolts to secure the cogged pulley. **Torque to 106 in-lbs.**

Ensure the cogged pulley on supercharger is 38mm diameter.

**Static Tensioner design:** The latest version is shown in the inset photo. See the following steps for belt installation detail.

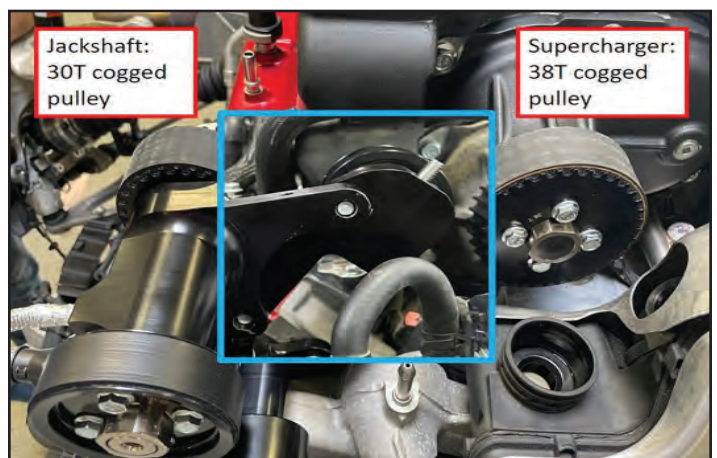



114. Install the cogged belt PN 79-83-00-720 over the cogged pulleys and under the idler pulley as shown. Ensure the belt seats fully into the grooves of the cogs. With the idler pulley bolt just loosened enough to allow it to slide, push down on the pulley until the lower span of the cogged belt just starts to create a straight line as shown with the yellow line. Tighten the set screw until it just contacts the slide nut to keep the idler in this position.

**Torque the idler bolt to 25 ft-lbs.**

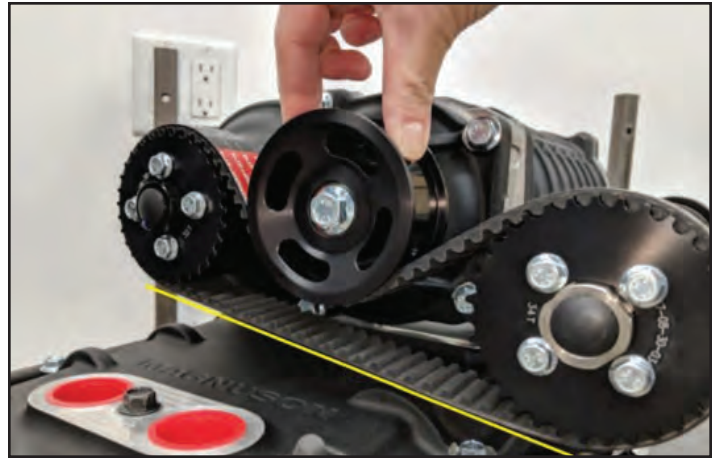

115. **Inspect for proper belt tension:**

Press up on the lower belt span to ensure that it does not make contact with the upper belt. The upper and lower belt teeth should be about 4mm apart.



116. If the lower belt overlaps the upper one, as shown here, further adjustments will be needed.



117. In this image the belt is too tight. Space between the upper and lower cog teeth is greater than 4mm.



118. Double-check the idler pulley bolt torque, ensuring it is **torqued to 25 ft-lbs.**

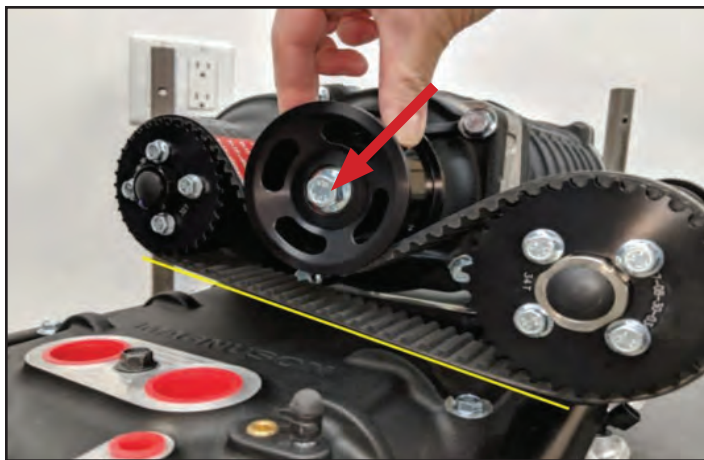

119. If A/C compressor was left installed on the engine, cut the OE belt and discard it. A new one is provided and will be installed in a later step.

Remove the OE accessory drive belt. It will not be reused.



120. Remove (3) water pump bolts.

Install idler bracket P/N 65-26-62-085 to engine using (3) socket head cap screws P/N 72-00-08-100. Apply blue Loctite 242 to all fasteners.

**Torque SHCS to 18 ft-lbs.**

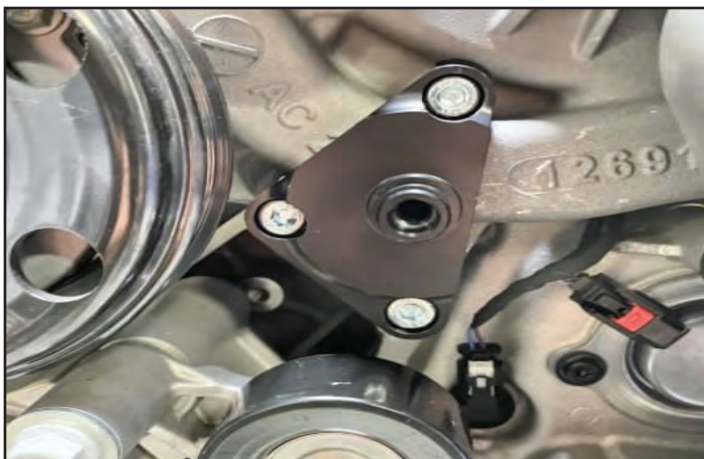

121. Install 56-50-47-001 Dayco pulley and (1) 71-10-15-030 (M10X30mm) bolt.

**Torque bolt to 41 ft-lbs.**





**122. Accessory Drive Belt Addendum A:**

Your kit may include the following items:  
 PIP seal P/N 80-59-10-561  
 PIP seal P/N 80-59-10-566  
 T-stat adaptor (billet) P/N 65-26-62-083  
 (2) Fasteners M6 X 35mm P/N 71-06-10-035  
 Gates belt P/N K060722 (not shown)

We have simplified installation of the kit and these items are no longer required to be installed. A shorter belt P/N K060710 (also supplied) will be used.

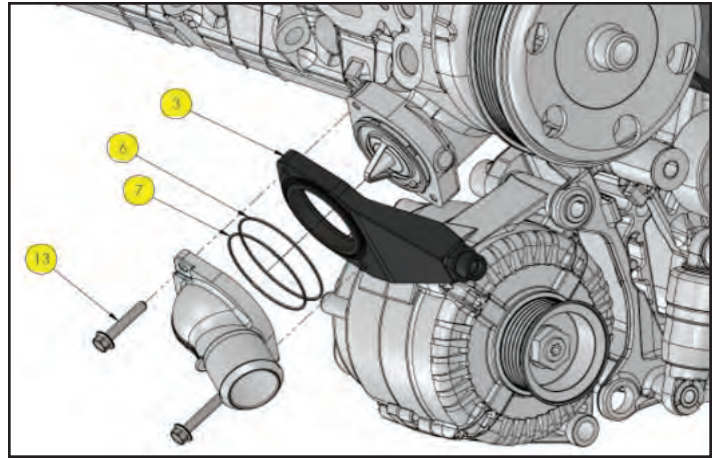
**123. Accessory Drive Belt Addendum B:**

Your kit may include the following items:  
 Idler P/N 56-06-01-054  
 Spacer P/N 69-05-00-038  
 Support Bar P/N 65-26-62-087  
 Fastener M10 X 50mm P/N 71-10-15-050  
 Fastener M10 X 120mm P/N 71-10-15-120

We have simplified installation of the kit and these items are no longer required to be installed.

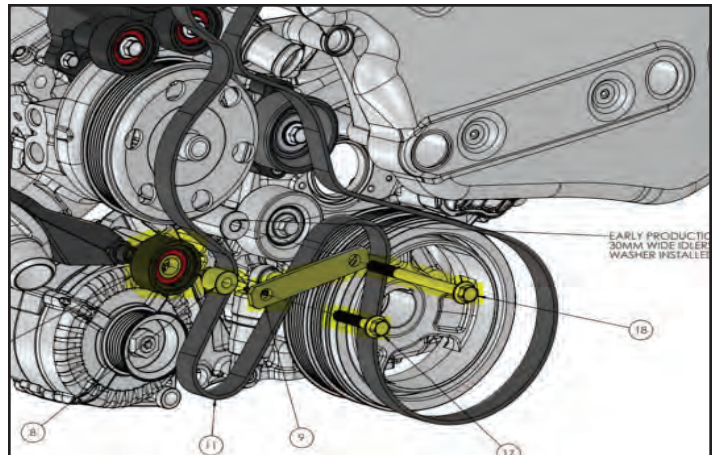

124. Cycle the tensioner and install the FEAD belt PN K060710 with revised routing as shown in blue over all pulleys, ensuring the belt is properly seated around each.

The belt will route directly between the water pump and the alternator.

**Note: all items highlighted in blue are no longer installed.**

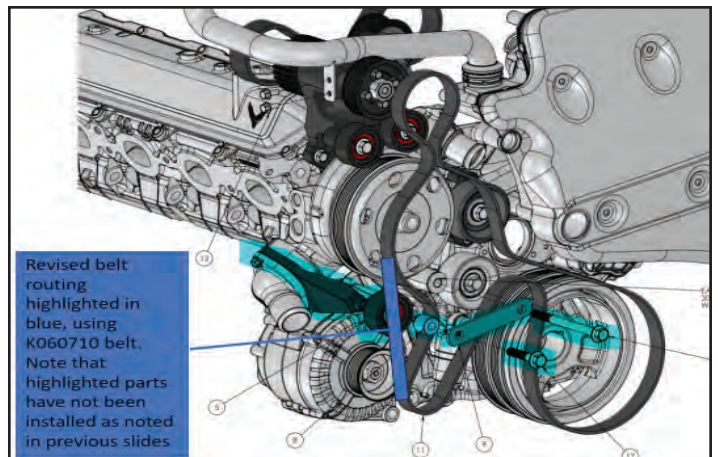

125. Re-install (2) rad hoses onto engine.

Install/position (1) constant tension clamp and position/tighten (1) gear clamp.

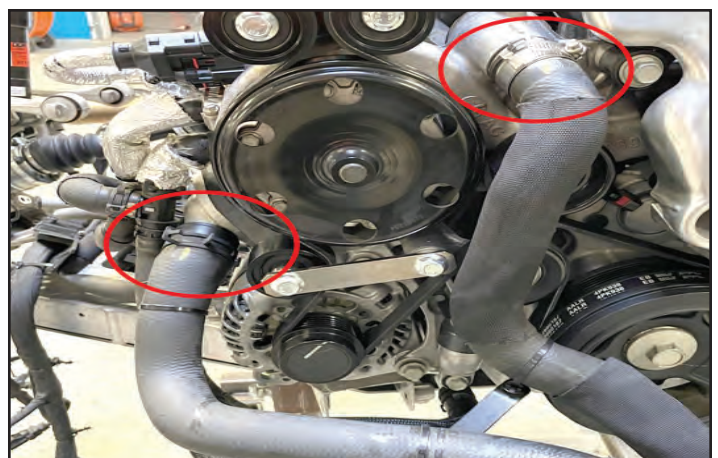

126. If the A/C compressor was left on the engine, install a belt stretch installation tool onto the front of the pulley.

Install a new A/C stretch belt (GM P/N 12660187) over the crank pulley and onto the installation tool. Rotate the crankshaft clockwise and install the stretch belt over the A/C compressor.

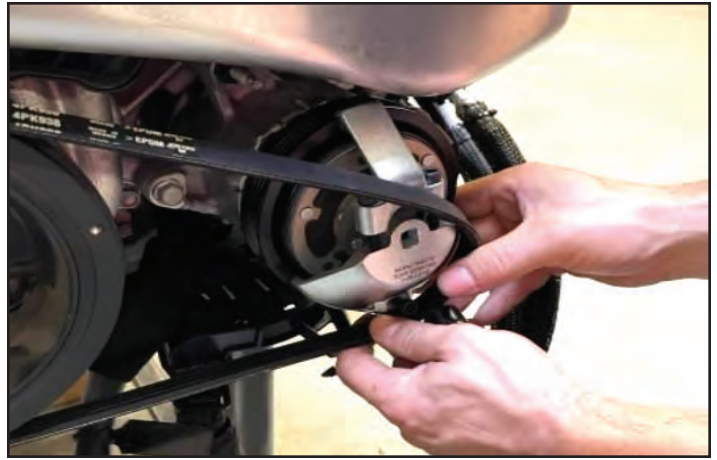

127. Verify the belt is seated properly around both pulleys.

Remove the installation tool.

Skip this step if the A/C compressor was removed.

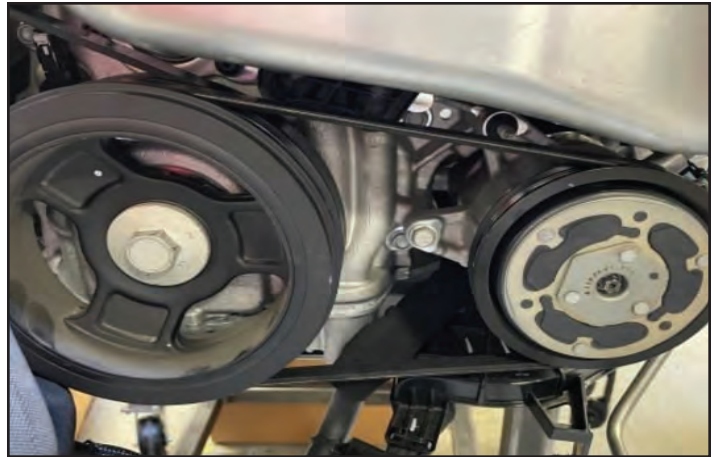

128. **Hose Installation**

Appendix A at the back of this manual provides detail on the hose part #'s.

Appendix B provides detailed hose routing for each part #.

All hoses are identified with an inkjet part # as shown in the adjacent photo.

In addition to Appendix A and B, we have also provided detail for the installation of each hose, in subsequent slides.

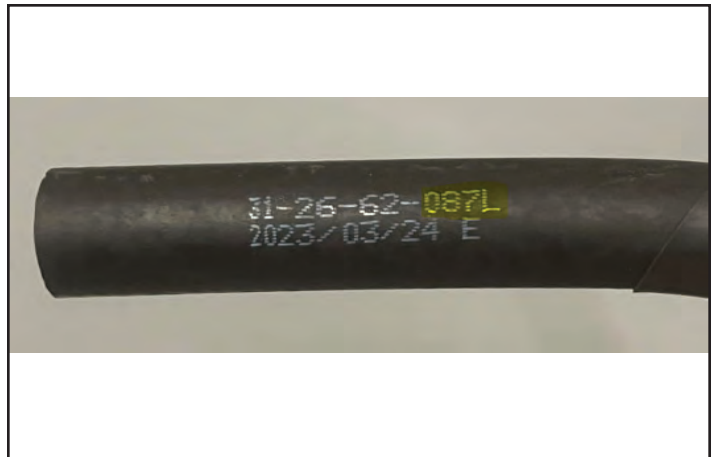



## C8 Corvette Hose Routing – IMPORTANT NOTE

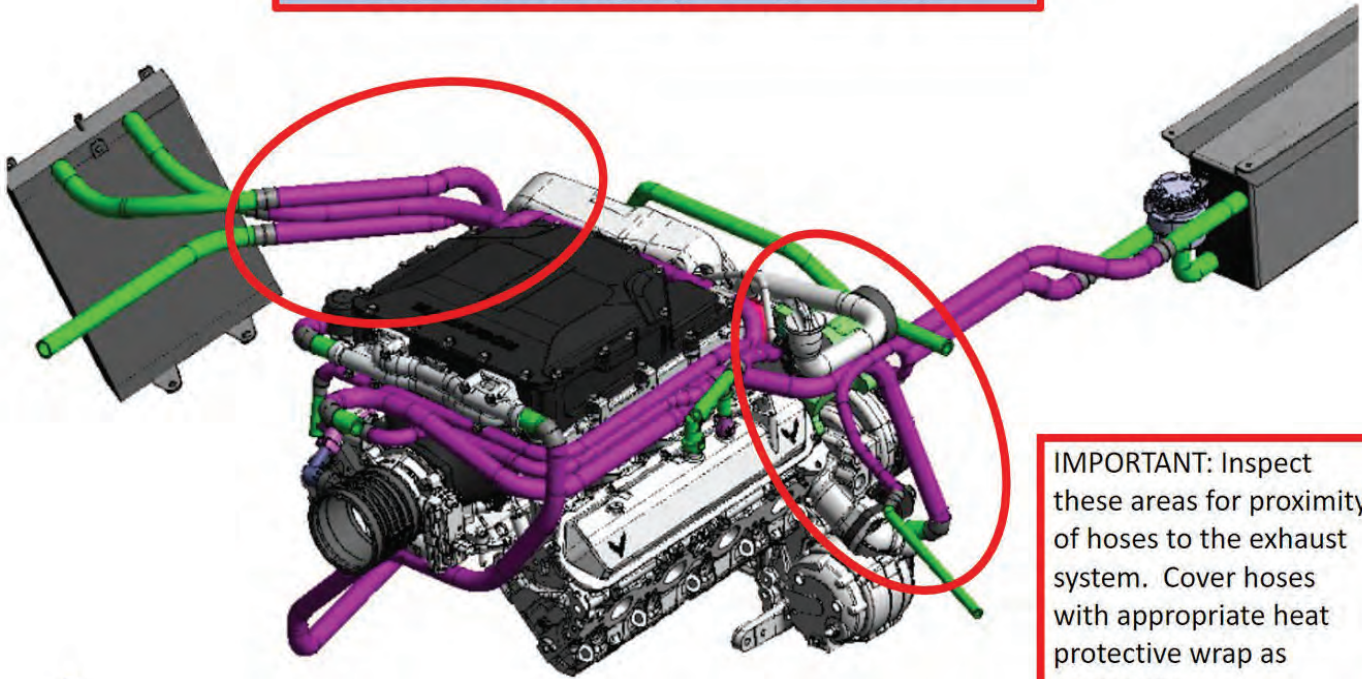

**IMPORTANT:** Inspect these areas for proximity of hoses to the exhaust system. Cover hoses with appropriate heat protective wrap as necessary

134

129. Remove the OE coolant bleed hose assembly from the spigot at the top of the water pump housing. Harvest the male quick connector from the end of this hose.

Select coolant hose 31-26-62-087F. This will replace the factory part.

Push the hooked end of the 087F hose through the hole in the jackshaft housing.

Install a 5/16" constant tension clamp at each end of the hose.

Install the hose onto the spigot at the top of the water pump housing. Secure the hose with the clamp.

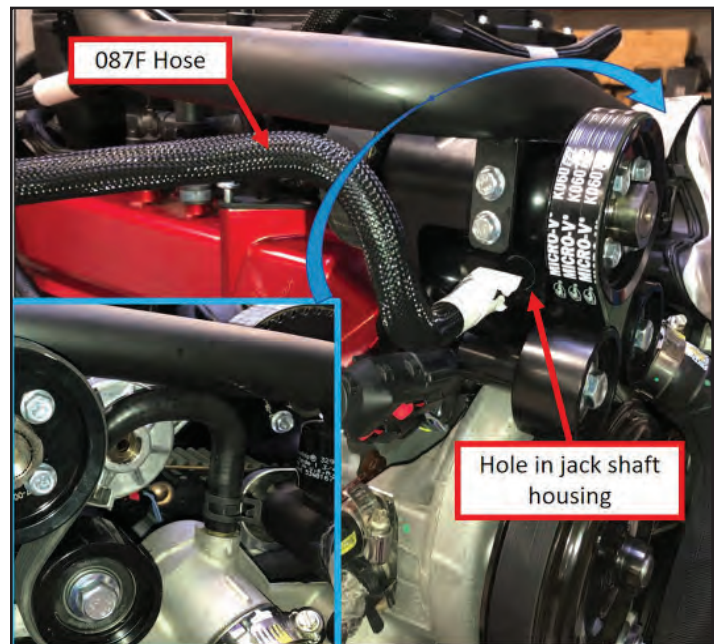

### 130. 087F Coolant Bleed Hose

**Coupe Only:** the 087F hose will be cut to fit after power train has been installed back in the vehicle. Set male connector aside.

**Convertible Only:** the 087F hose will be installed onto the top of the factory coolant reservoir after the power train has been re-installed. It does not need to be shortened.

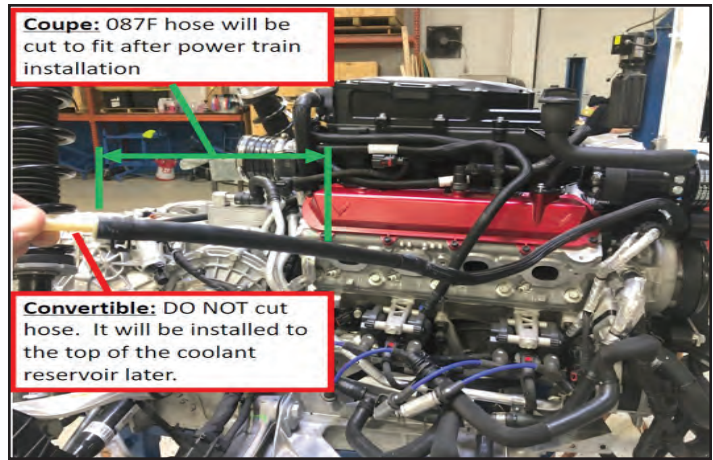

### 131. Purge Valve and Hose

Install the purge valve and fastener (harvested from the OE intake) into the port on the LH side of the throttle body adaptor.

**Torque the purge valve fastener 88 in-lbs.**

Re-install the purge valve electrical connector.

Select Hose P/N 31-26-62-087L. Install a 3/8" constant tension clamp onto each end.

Install a 3/8" 90 degree SAE fitting P/N 48-46-02-032 from the kit onto Hose 087L. The 90 degree fitting goes on the end of the hose shown in the photo.

Install the 087L hose sub-assembly onto the purge valve nipple. Engage the lock on the fitting to secure it. Route the hose per the diagram in the Appendix. The opposite end of this hose will be installed onto a body line connection at a later step.

132. Bend hardshell connector away from LH rear side of throttle body adaptor as necessary.

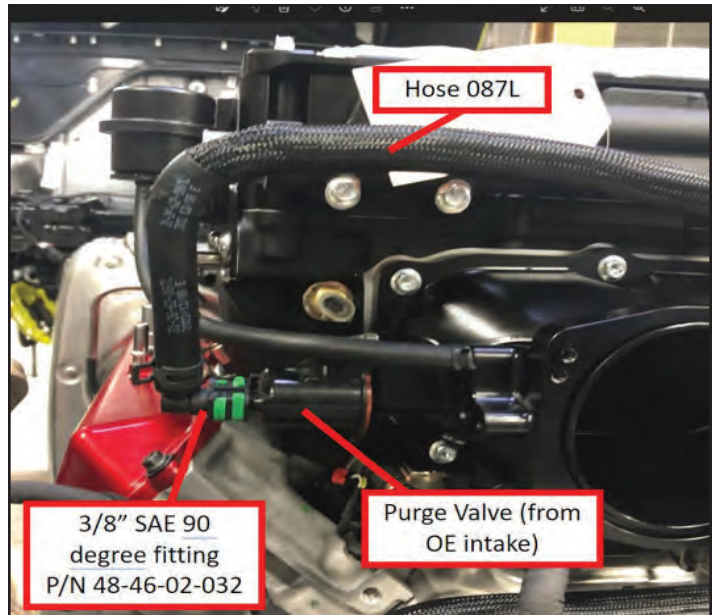



133. Remove (2) SC cover fasteners from the RH side of the supercharger, in the locations noted in the photo.

Pre-install zip ties into Hose Bracket P/N 65-26-62-089

Install the hose bracket to the RH side of the supercharger, then re-install the 2 fasteners.

**Torque the fasteners 18 ft-lbs.**

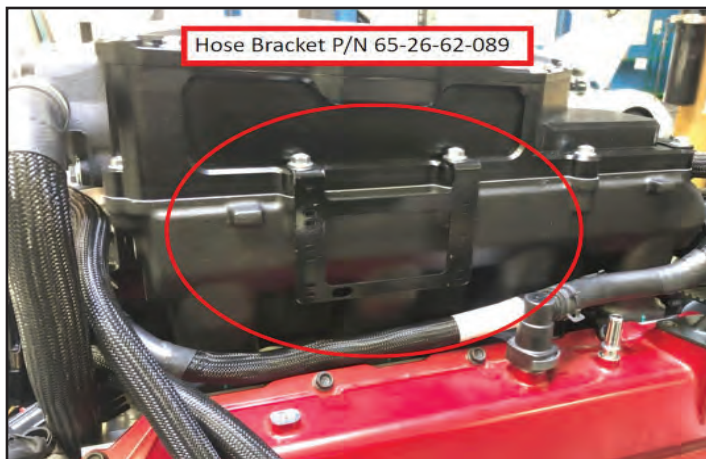

134. Trans Cooler Fittings / Line Routing

Remove both trans cooler fittings and swap them side for side.

Re-install constant-tension clamps over hose connections.

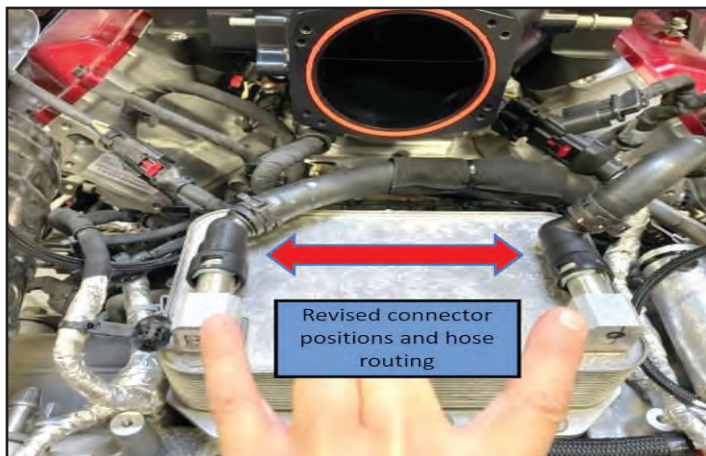

135. Add a 4 inch piece of rubber hose (not included in kit) between LH trans cooler line and trans cooler to protect the hose from abrasion against the cooler.

Zip tie both ends to the OE hose.

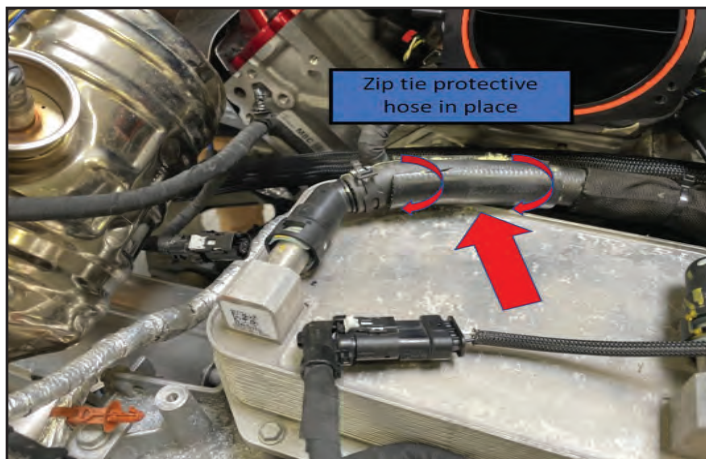

136. Bend trans cooler lines inboard toward engine.





137. Pre-install (4) long zip ties through holes in Oil Reservoir Bracket P/N 65-26-62-088.

Install coolant hose bracket to dry sump tank at LH front of engine using the original fasteners in the positions shown in the photo.



138. Remove wiring harness @ RH rear of engine from the mounting bracket.

Disconnect the harness @ hard shell connector and loop it in between the two trans cooler lines.



139. Re-connect the hard-shell connector from the last step as shown here.

Ensure oil cooler hoses are not kinked.

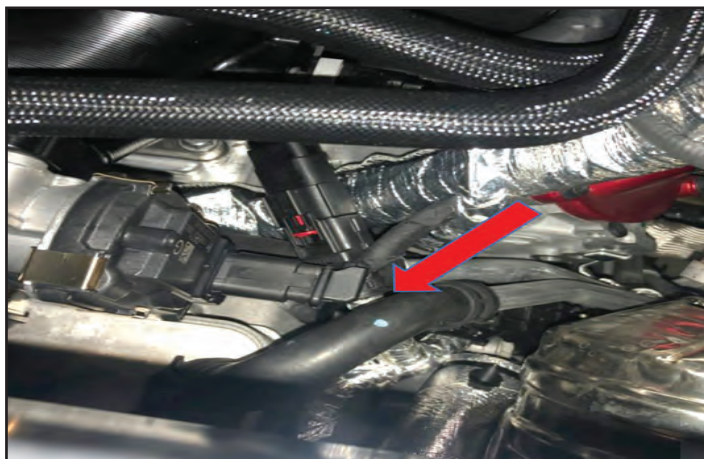

140. Install and route the LH CAC hose at the rear of supercharger.

Hose 31-26-62-087A installs onto the LH (drivers) side port at the rear of the supercharger. Secure the hose using a 3/4" constant tension clamp.

Route the LH 087A hose along the LH side of the supercharger toward the front of the engine. The opposite end of this hose will connect to the low temp radiator (forward connection) after the powertrain has been re-installed in the vehicle.

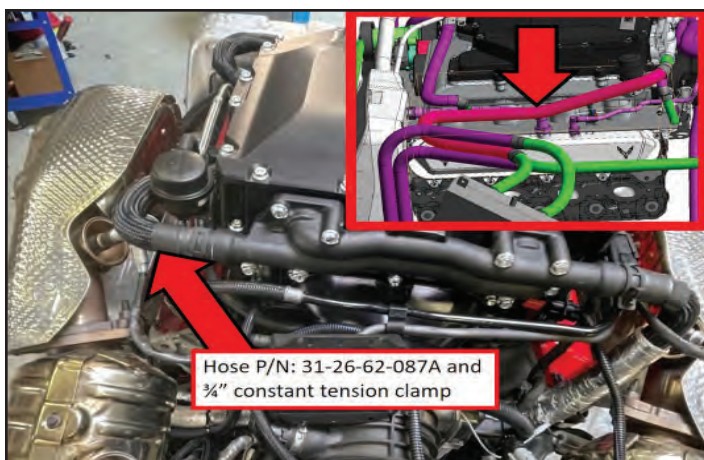



141. Zip ties secure the wiring harness inside a plastic trough at the back of the engine. Trim the tops with flush cut pliers so they do not stick up and rub on the coolant lines.

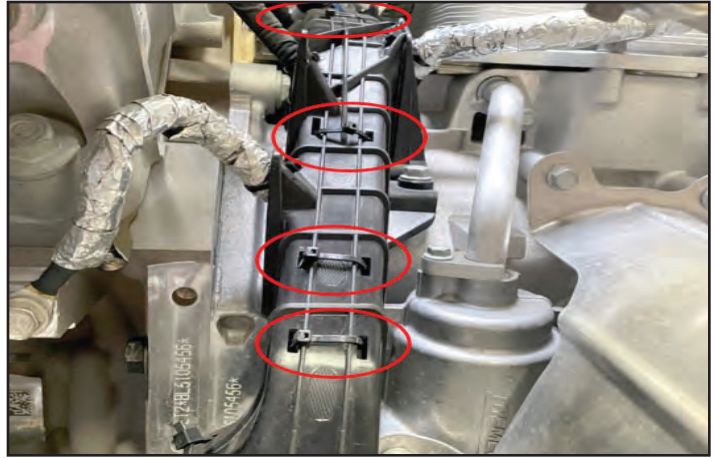

142. Install and route the RH CAC hose at the rear of supercharger.

Hose 31-26-62-087C installs onto the RH (passenger) side using a  $\frac{3}{4}$ " constant tension clamp.

Route the hose under the throttle body adaptor and over to LH front corner of the engine. The opposite ends will connect to the underbody coolant tank and to the fill bottle inside the engine compartment after the powertrain has been re-installed in the vehicle.

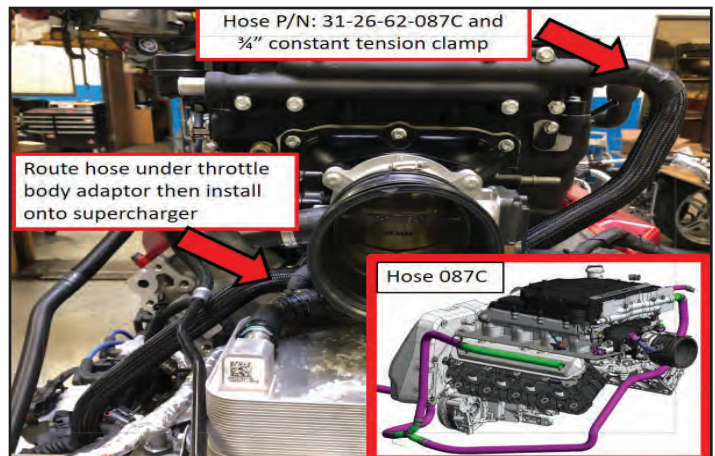

143. Use (2) zip ties to secure hose 087C to the rear most position of the previously installed dry sump tank bracket. Select Hose 087B and secure it to the forward position of the dry sump tank bracket using (2) zip ties.

This hose will install between the rear most low temp radiator connection and the intercooler pump under the vehicle. Hose routing detail can be found in the image on the next page.

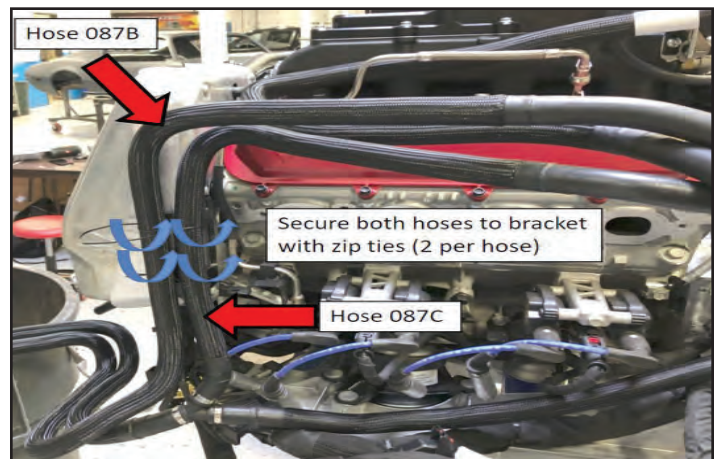

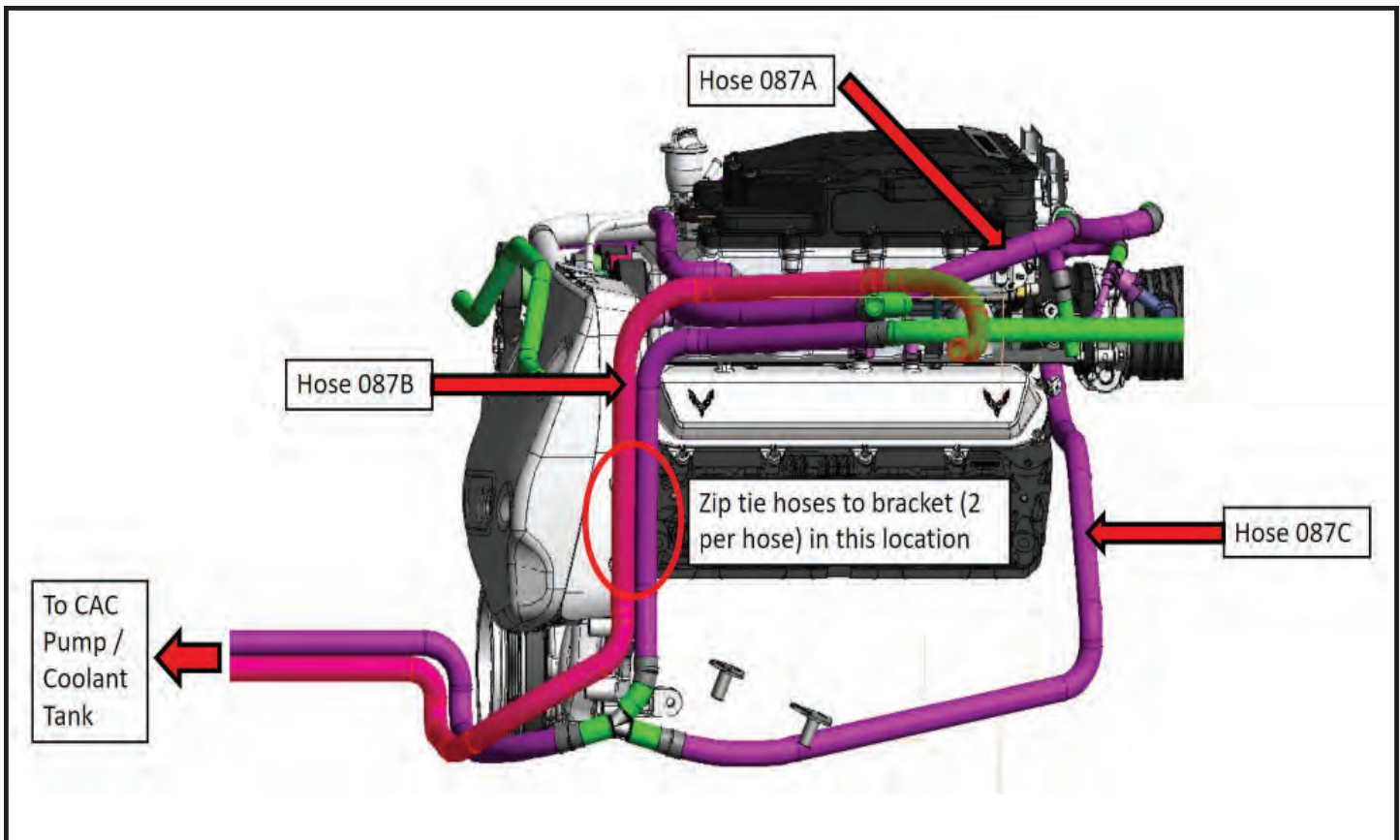

144. Select the revised throttle body from the kit.

Install the supplied throttle body o-ring to the supercharger inlet adaptor. Install the revised ETB using the original fasteners from the OE ETB.

**Torque the fasteners in a criss-cross pattern to 106 in-lbs.**



145. Re-install the ETB electrical connector, ensuring that it is fully seated and the lock has been cycled on the hardshell connector.





146. Remove the OE MAP sensor (PN 12711681) from original intake and install to the LH side of throttle body adaptor. Secure the sensor to the adaptor using an M6 X 1 - 25mm long fastener P/N 71-06-10-025, from the supercharger kit.

**Torque the sensor bolt to 106 in-lbs.**

Re-install the OE MAP sensor plug into the sensor, ensuring the blue tab has slid to the locked position.

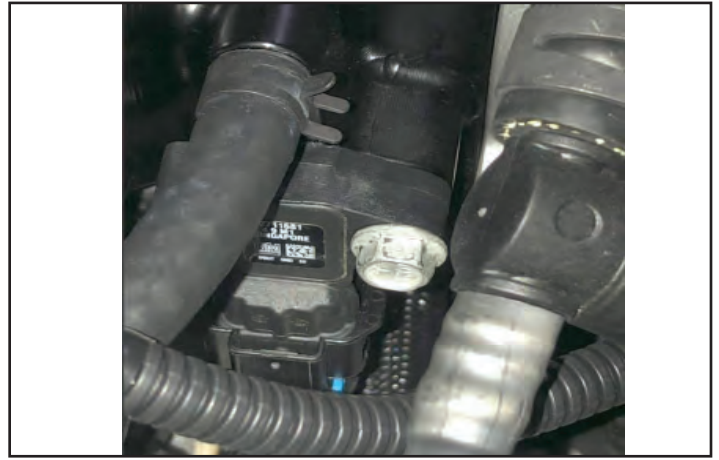

147. Carefully cut the hose ends off the original PCV line with a knife, ensuring you do not cut the o-ring that is internal to the barbed fitting.

Select new PCV line P/N 31-26-62-087H.

Install 3/8" clamps on each end then re-install the original hose ends as shown in the photo. Secure the connectors to the hose with the clamps.

Orient the hose ends and install onto the engine as shown in the following step.

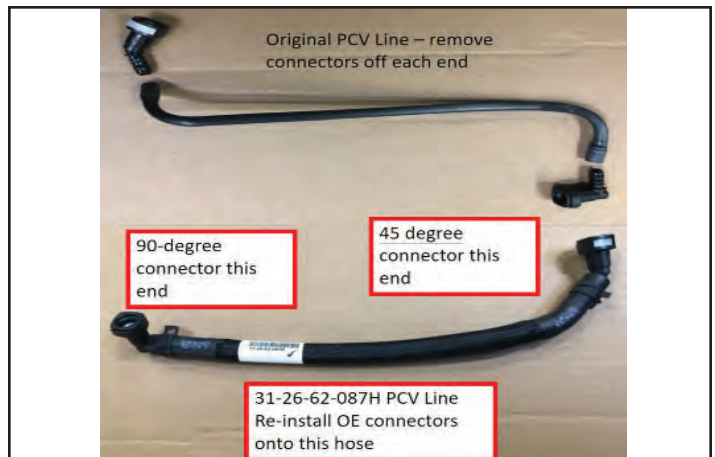

148. **087H PCV hose orientation as shown**

(45-degree fitting connects to the fitting on the throttle body adaptor.

90-degree fitting connects to hose in between cylinder 2 and 4 intake ports.

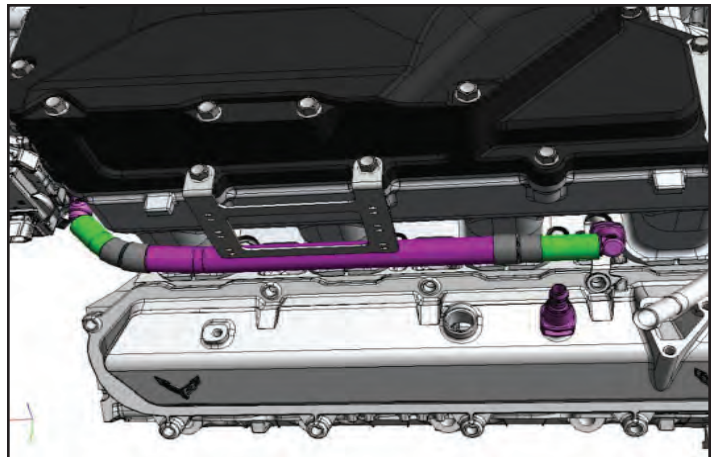

149. Remove (2) fasteners from the RH front corner of the supercharger cover.

Install PCV Crossover Hose bracket P/N 65-26-62-090 onto the corner of the cover then pre-install the original (2) fasteners. **DO NOT TIGHTEN THE FASTENERS** - the revised PCV hose assembly will be tucked under this bracket during installation in a subsequent step).



### 150. PCV Tube Fabrication:

Carefully cut the 90-degree quick connector off the factory PCV tube assembly as shown in the photo.

Carefully cut the opposite end of the hose off the T connector. Discard the section of OE hose.

Re-install the remaining section of the factory tube that has the T connector, back onto the engine, between the dry sump tank and the LH valve cover, with the T facing up and out at a 45-degree angle.

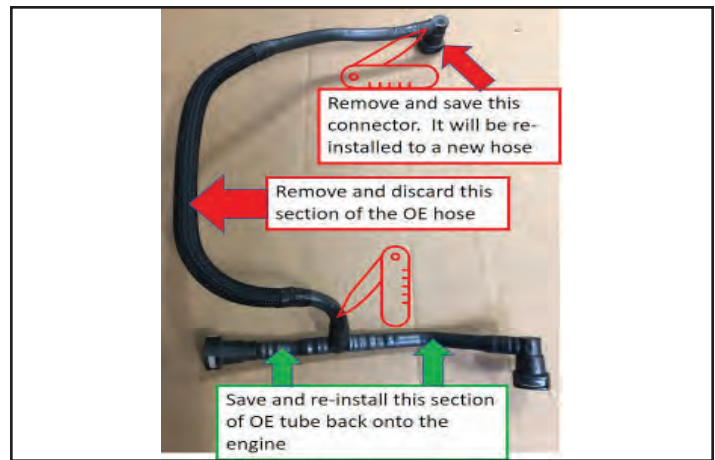

### 151. Select Hose 31-26-62-087J.

Install a ½" constant tension clamp onto the hose then install the hose onto the Tee fitting of the OE PCV line that goes between the dry sump tank and the LH valve cover.



### 152. Tuck the 087J PCV hose under the previously installed bracket.

Loop a zip tie through the bracket and around the hose.

Rundown and **torque the SC cover bolts 18 ft-lbs. to secure the bracket.**

Secure the 087J hose to the bracket using the zip tie. Cut off any excess material.

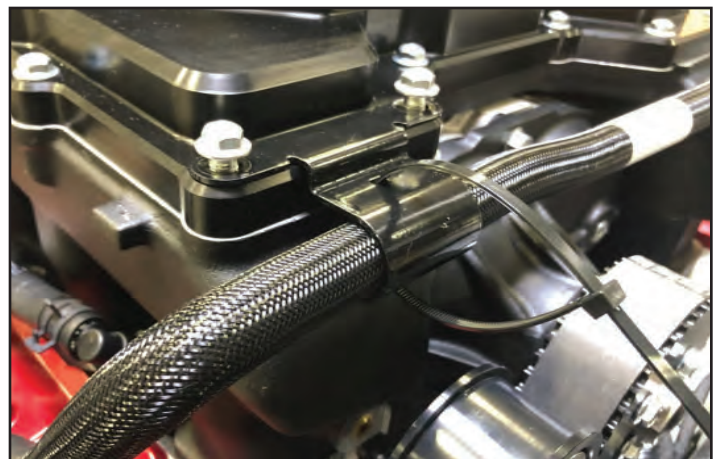

### 153. Route the opposite end of the 087J hose around the RH front corner of the supercharger, and toward the PCV connector on the RH valve cover.

Install a ½" constant tension clamp over the end of the hose, then install the 90-degree quick connector harvested from the OE PCV hose, onto the end of the 087J hose. Secure the hose using the constant tension clamp.





### 154. PCV Fresh Air Hose Assembly

#### Modification

Cut and remove the hose from the RH side of the Tee connector as shown.

Cut and remove the straight quick connector from the opposite end of the hose as shown.

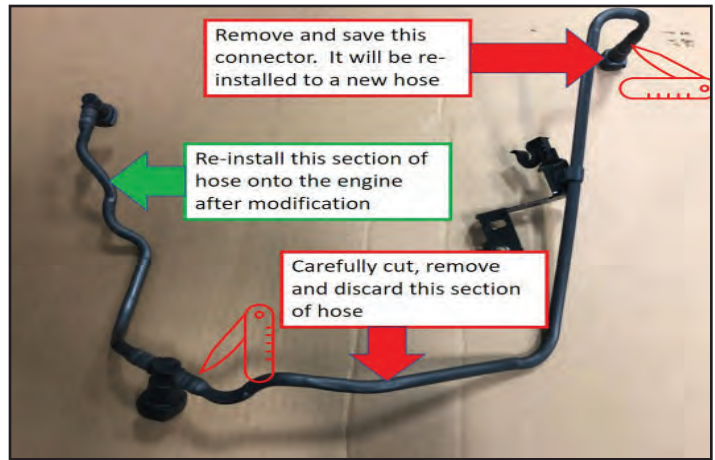

### 155. PCV Fresh Air Hose Assembly

#### Modification

Re-install the original section of the fresh air hose assembly back onto the engine, between the LH valve cover and the rubber throttle body adaptor fitting as shown.

Select hose 31-26-62-087G and route it between the Tee connector and the fitting on the passenger side valve cover as shown. Install 3/8" constant tension clamps onto both ends of the hose, then install the straight quick connector previously removed onto the opposite end at the valve cover.

\*Hose routing overview on next image.

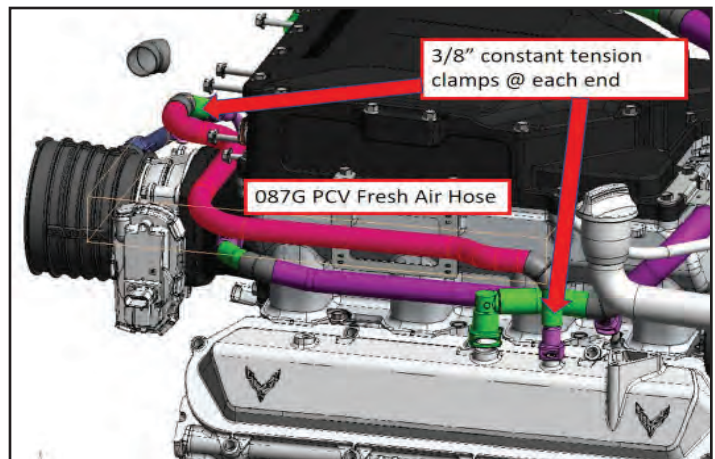
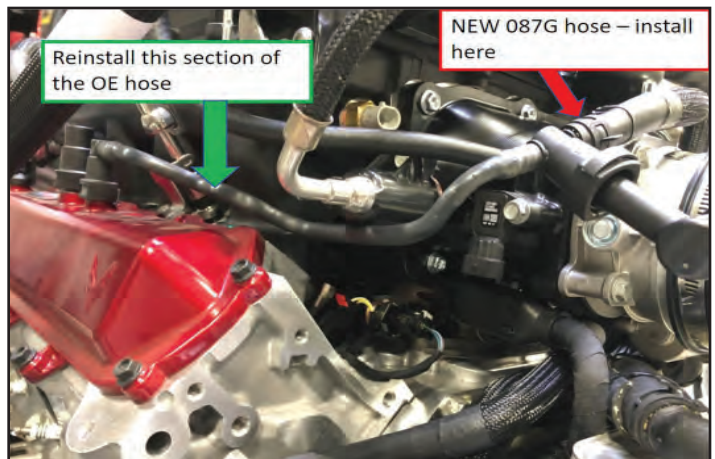

### 156. 087G PCV Fresh Air Hose Routing Overview

Install 3/8" constant tension clamps at both ends of the 087G hose.

Install this hose onto Tee fitting at throttle body adaptor.

Install the female quick connector harvested from the OE assembly onto the opposite end of the 087G hose.

Slide constant tension clamps over hose ends to secure the fittings at each end.

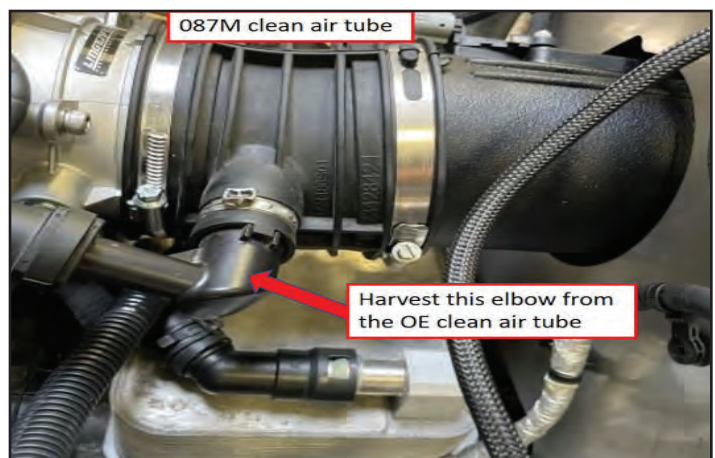

157. Harvest the OE plastic 90-degree elbow from the OE clean air tube and re-install/orient it onto the new Magnuson Clean Air Tube P/N 31-26-62-087M found in the hose kit bag. Secure the elbow with an Oetiker clamp from the kit.

Install the clean air tube to the ETB and tighten it using the supplied gear clamp.



158. Select the billet reservoir adaptor from the kit. Harvest the o-ring from the original oil fill tube and install it onto the adaptor. Lubricate the o-ring with oil and install the adaptor into the top of the dry sump tank.



159. Install a Gates Powergrip heat shrink tube P/N 32948 over the end of the adaptor where it connects into the dry sump tank. Lift the heat shrink tube up approx. 1/8" to center it over the joint then heat shrink it over the joint between the billet adaptor and factory reservoir. Select the 1" diameter 90-degree section of hose from the kit. Install a #16 gear clamp from the kit over the hose then install the hose onto the reservoir adaptor as shown. Tighten the clamp securely.



160. Select the oil fill tube PN 35-26-62-089 from the kit. Slip another #16 gear clamp over the end of the hose then install the oil fill tube as shown. Position it so that the bolt holes in the tube align with those in the jackshaft bracket. Select (2) M6 X 16mm long fasteners, apply blue Loctite 242, hand-start and zero-torque them through the oil fill tube brackets into the jackshaft bracket.

**Torque both M6 fasteners 106 in-lbs.**

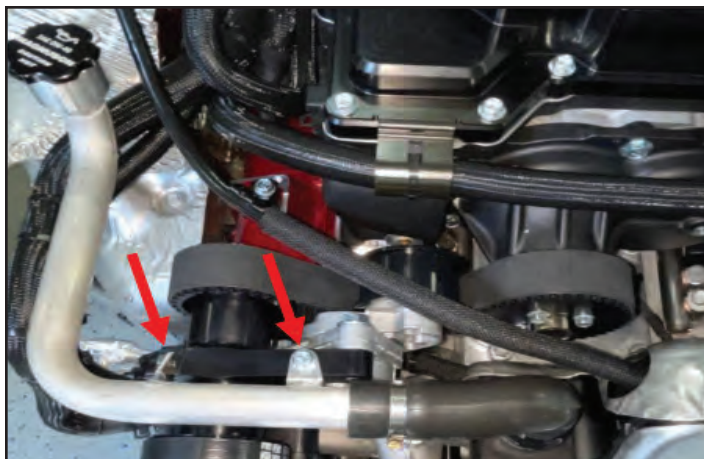

161. Position the gear clamp over the tube to hose interface then tighten it to secure the hose.





162. Carefully bend the OE dipstick tube up in the areas shown to allow it to be installed into the dry sump tank and also fit above the 1 1/2" standoff P/N 69-05-00-007 which installs into the front of the RH valve cover.

Ensure it does not come into contact with any of the supercharger pulleys after it has been installed.

See next photo for final installation.

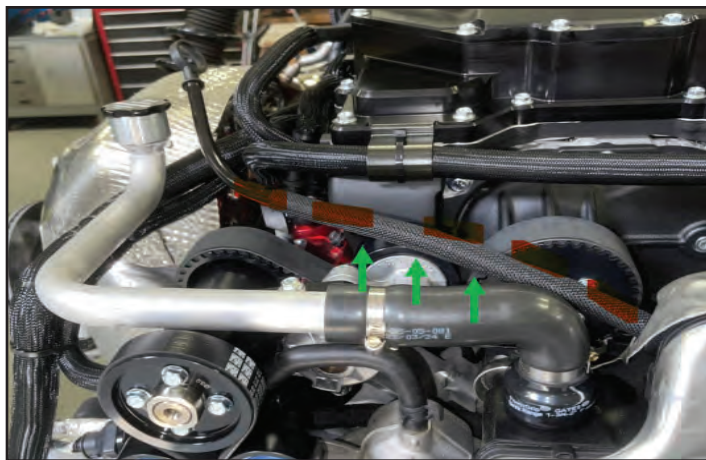

163. Select the 1 1/2" stand-off P/N 69-05-00-007 from the kit and install it between the oil dipstick tube bracket and the RH valve cover.

Install (1) M6 X 50mm long fastener P/N 71-06-10-050 through the oil dipstick tube bracket, stand-off and into RH valve cover in the hole shown.

**Torque the fastener 106 in-lbs.**



164. Install push pin for LH oxygen sensor wiring harness takeout into the rear of the LH cylinder head.

Loop the harness as required, ensuring it is away from the exhaust system.

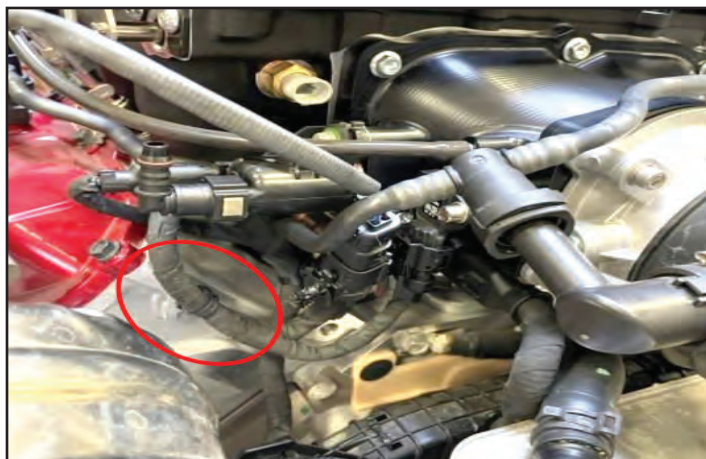

165. Re-install the airbox.

Secure the airbox to the clean air tube by tightening the gear clamp.

Secure (1) temp sensor at the bottom right of the airbox.

Secure (2) wiring harness fir tree connectors onto bottom rear corners of the airbox.

Secure the airbox to the engine using the original (2) fasteners at the locations circled.





166. Install oxygen sensor harness takeouts onto airbox retention clips.

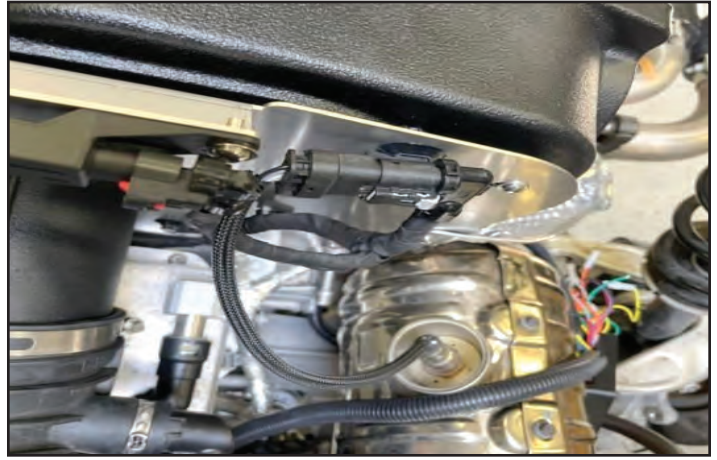

167. Select the IAT sensor relocation module from the kit P/N 82-55-80-107. There are 4 wiring connections that will be made under hood: IAT sensor, Baro sensor, MAF sensor, MAF harness. See the following slides for detail.

**Note:** the wiring connections will all be made now, however the module will remain stowed in a safe place at the back of the supercharger until the power train has been re-installed in the vehicle.

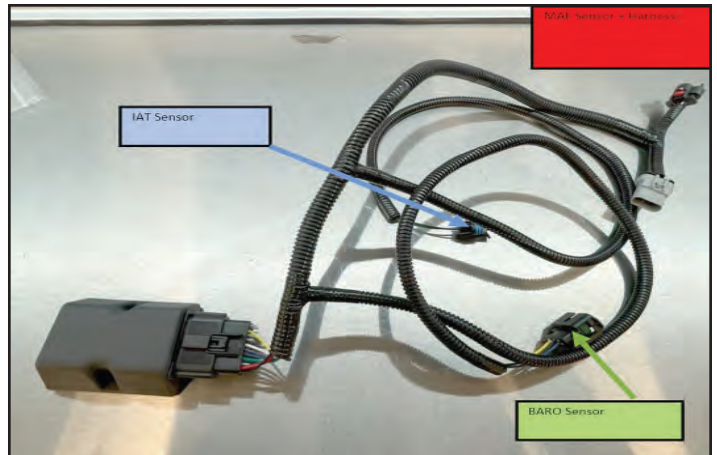

168. Route and connect the 2-pin harness from the relocation module over to the gold-colored IAT sensor on the LH rear of the supercharger.

Ensure the connector is fully seated.



169. Select the GM Baro sensor P/N 12711681 from the kit. Connect the sensor to the wiring harness on the relocation module.

Zip tie this sensor to the underside of the clean air tube as shown, ensuring the port (end with the green o-ring) faces down.

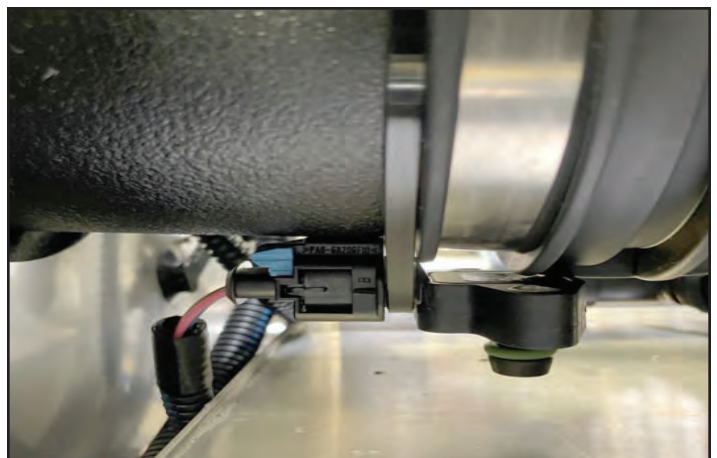



170. Connect the wiring harness with the black hardshell connector into the factory MAF sensor located at the front of the airbox, near where it connects to the clean air tube. Ensure the locking mechanism on the connector is cycled.

Connect the remaining harness with the gray hardshell connector into the factory harness with the gray connector.

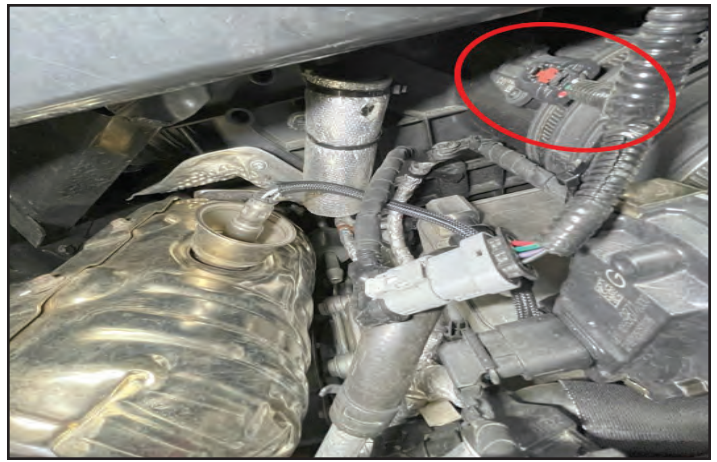

### 171. **087K Fuel Tank Vent Crossover**

Remove OE crossover line from the front of the engine compartment.

Carefully cut the quick connectors off both ends of the OE crossover line using a razor blade.

Carefully remove the silver reflective heat shielding tape from the OE crossover.

Select the revised pre-formed cross-over hose P/N 31-26-62-087K. Slide a 5/8" constant tension clamp over each end of the new pre-formed hose.

Install OE connectors to the revised pre-formed hose. \*\*The female connector goes on the side which has a longer leg (see photo).

Install the OE heat shield over hose.

Install revised hose assembly back onto the vehicle ensuring the connectors lock into place.

Zip tie the hose in place.

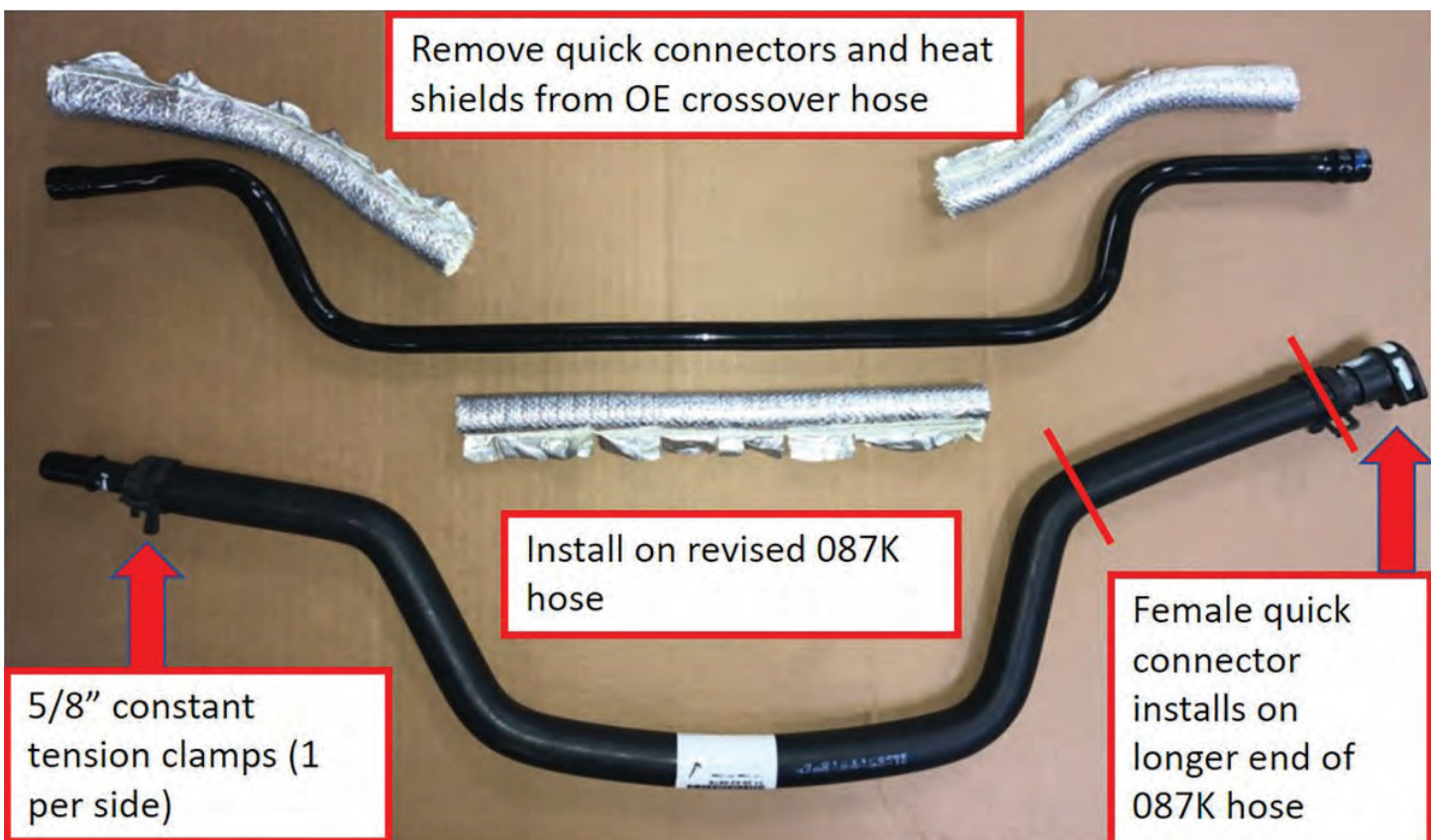



### 172. **087K Fuel Tank Vent Crossover**

Remove (2) black plastic clips that secured the OE crossover to the firewall.

Install a zip tie through the holes on each aluminum bracket. These will be used to secure the new 087K crossover hose to the panel.

Install the revised hose assembly into each quick connector ensuring it locks into place.

Install the green locks into each connector. Punch holes in the heat shield panel as necessary then fasten the hose to the heat shield using 4 zip ties. Trim the zip ties.

**IMPORTANT: this hose must be secured as far forward as possible to ensure it does not rub on the pulleys.**

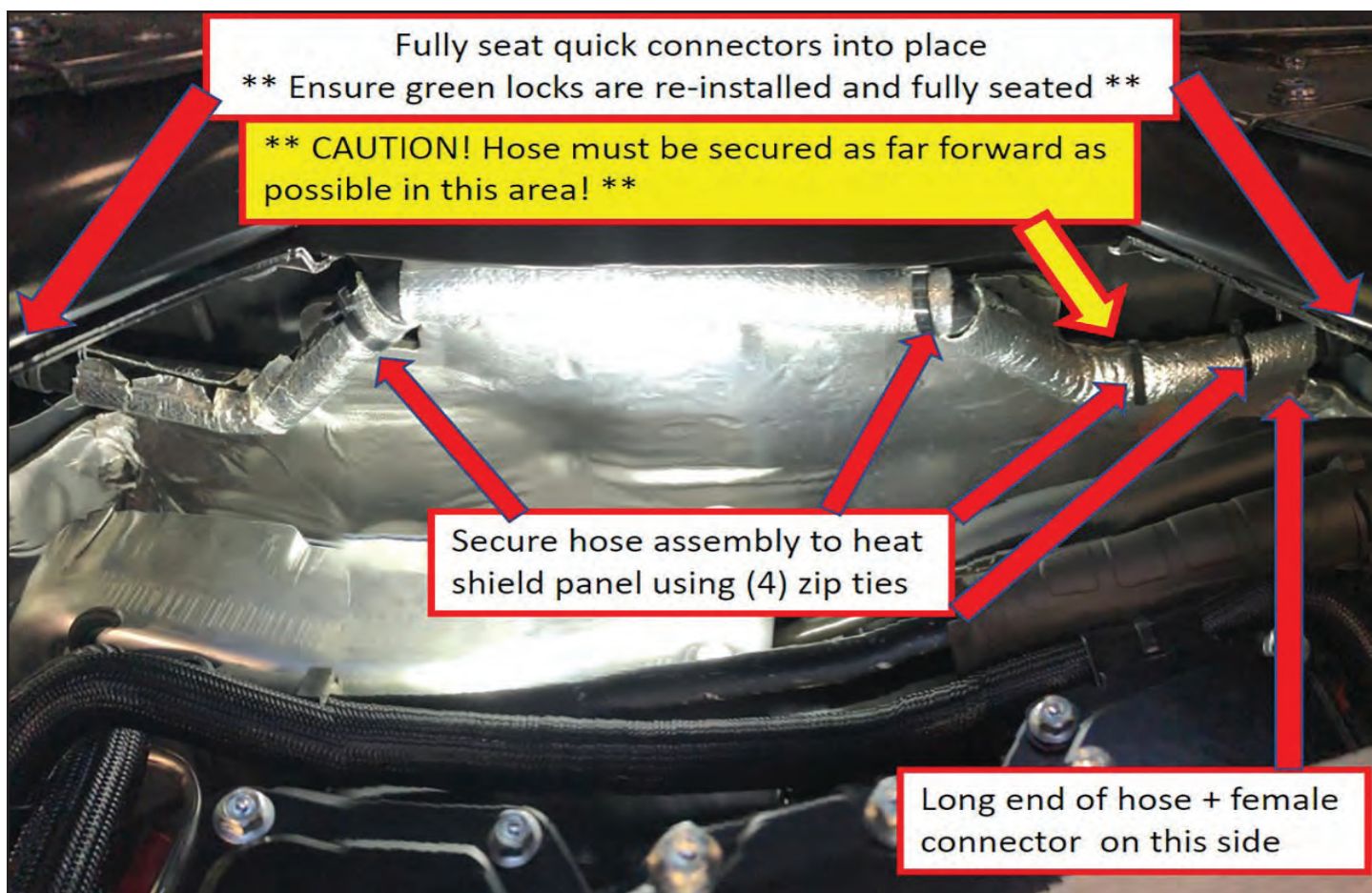

### 173. **087E Hose (Convertible ONLY):**

Route coolant hose 087E along RH side of engine as shown.

Pre-install a  $\frac{3}{4}$ " constant tension clamp to each end.

Install the 087E hose to the factory connector by the water pump @ RH front of engine. Apply a constant tension clamp to hose.

The connection point at the opposite end will be made in a subsequent step.

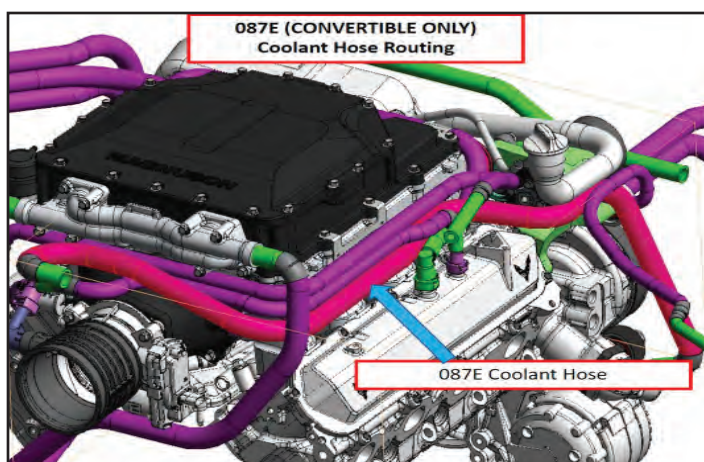



174. If removed for draining purposes, re-install coolant hose to line @ bottom of engine and apply constant tension clamp.



175. **Convertible Only:** Apply blue Loctite 242 to (4) black button head screws included in the kit. Fasten the supplied mounting bracket to the fill reservoir using the screws.

Locate the factory-installed riv nuts on the LH side of the rear structural panel inside the engine bay. Install the fill reservoir sub-assembly into this location using the supplied M6 fasteners.

**Coupe:** the fill reservoir will be installed in a subsequent step. Disregard this page.



176. **Convertible Only:** Remove the under tray from the coolant de gas bottle.

The following slides will detail modifications required to be made to the tray to alleviate contact with the supercharger hoses.

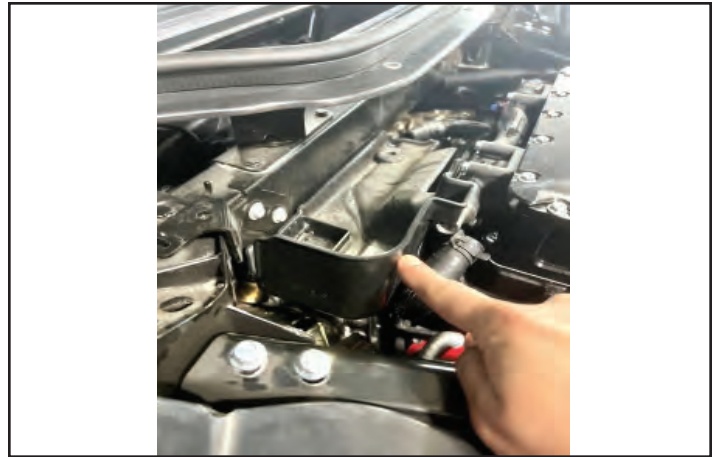

177. **Convertible Only:** Remove (1) Torx fastener securing the reservoir to the tray from underneath.



178. **Convertible Only:** Remove (1) Torx fastener securing the reservoir to the tray from the top.



179. **Convertible Only:** Remove the factory hose from the reservoir.

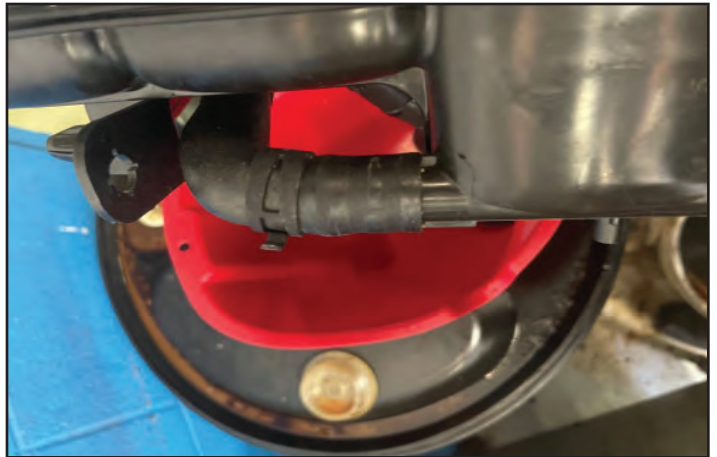

180. **Convertible Only:** Remove the reservoir from the vehicle.

Remove the hose from the top of the reservoir as shown. It will not be re-used (the 087F hose will attach to this port after the power train has been re-installed).



181. **Convertible Only:** Remove the factory hose from the reservoir in the location shown.

This hose will not be re-used.





182. **Convertible Only:** Remove the drip tray from the vehicle.

Using a band saw or cut off wheel, carefully remove the section of plastic shown in the photo.

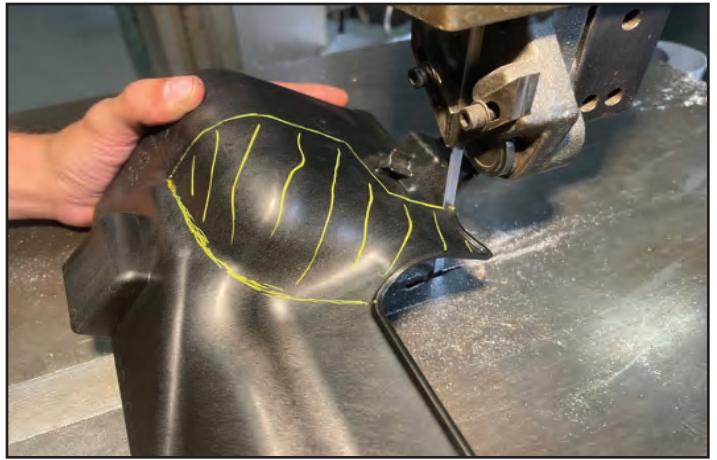

183. **Convertible Only:** Radius and blend the edges as required to eliminate any sharp edges.



184. **Convertible Only:** Reinstall the modified drip tray back onto the factory coolant reservoir, securing it using the original Torx fasteners.

Route and connect the 087E hose (highlighted in red) to the bottom port of the coolant reservoir, securing it with a  $\frac{3}{4}$ " constant tension clamp from the kit.

Lay the reservoir sub-assembly on top of the throttle body for now, it will get re-installed into the vehicle when the power train is re-installed.



185. Remove stock fan/shroud mounting assembly from inside LH rear wheel well. Remove the fan and shroud from the mount by removing (1) fastener and (2) push pins. Remove J-clip and (2) rubber isolators from the OE fan mount (see inset photo). If using an OE radiator, install the shroud to the front side and re-fasten it using the OE hardware.

If using aftermarket (Magnuson) radiator P/N 68-01-00-198, install the J-clip onto the upper radiator mounting tab, install (2) OE isolators onto the lower radiator pins, then install the OE shroud to the rad as noted above.

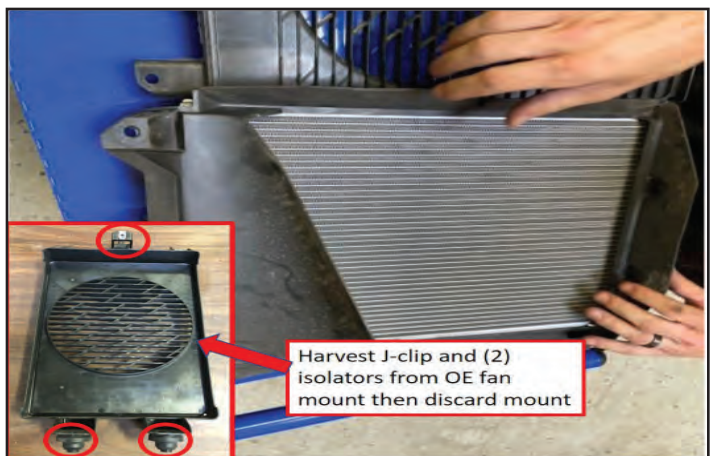

186. Re-install the new rad/shroud assembly into LH wheel well. Fasten it using the OE hardware.

Install the fan onto the rad. **Note: the OE fan shroud fastener MUST be replaced with a shorter M6 fastener (16mm long)** from the kit (Fastener P/N 71-06-10-016) or it will contact the radiator tank.

Re-connect the fan electrical plug (circled).



187. If A/C system was evacuated and opened, install new A/C bulkhead o-rings @ 2 underbody connection points.



188. **IMPORTANT: Prior to re-installation of power train, inspect the underside of the welded body structure at the right- hand front corner of the engine bay for excess, low-hanging frame weld.**

Metal to metal contact may occur between the welded zone and the oil fill tube as the engine moves during hard acceleration. Modify the oil fill tube if necessary, or metal finish ONLY the excessive low-hanging portion of the weld, ensuring there is sufficient clearance to prevent hard contact.



Continue to next page.



### 189. **Powertrain Re-Installation**

Re-install powertrain into vehicle. Using the aid of (4) helpers, carefully lower the vehicle down onto the sub-frame, ensuring nothing gets pinched or damaged.

**Note:** If A/C compressor was removed from the engine, it must be installed as the body is lowered to within ~ 6 inches of the power train. Install a new A/C compressor stretch belt at this time (GM P/N 12660187).

**Convertibles Only:** Re-fasten the factory coolant reservoir back into the vehicle at the appropriate point as the body is lowered back onto the power train.

Lower the vehicle to contact the sub-frame; use a long tapered drift pin to align the (4) holes in the sub-frame with those in the vehicle.



190. Apply blue Loctite 242 to (4) rear sub-frame bolts and hand-start in all locations.

**Torque (4) sub-frame bolts to 118 ft-lbs.**

After bolts are installed and torqued, the fixture can be removed from the sub-frame and moved out of the way.

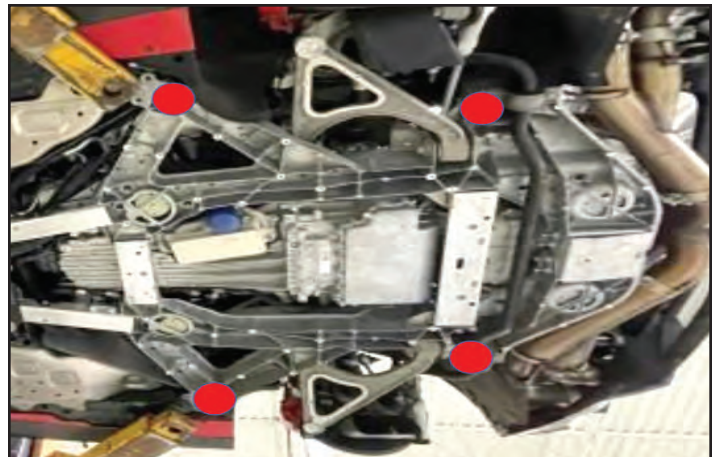

191. **Coupe Only:** Find the Fill Reservoir template at the back of this document.

**IMPORTANT: Ensure your print settings are set to Actual Size before printing. Use calipers or a ruler to verify the 105mm reference dimension is actual size on the printed copy.**

If needed, your printer settings can be adjusted to enlarge or reduce the print size as necessary to achieve the proper template size.



192. **Coupe Only:** Cut out the circular paper template and place it into the center of the recessed area in the fiberglass panel on the LH side of the engine, with the arrow pointing toward the front of the vehicle. It can be taped in place to secure it.

While holding the template stationary, use a 11/64" drill to pre-drill all 5 holes through the body panel. **Finish drill ONLY the 4 outer holes with a 15/64" drill.**

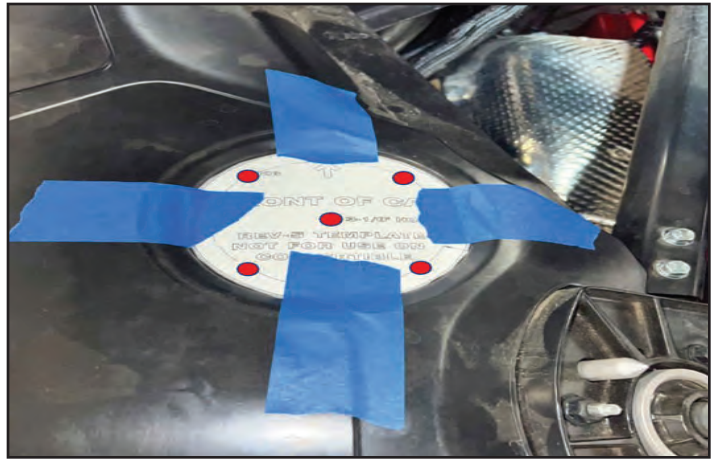

193. **Coupe Only:** Using a 3 1/8" hole saw, cut a hole in the center location as shown.

Use a vacuum while cutting to minimize airborne dust.

Sand the circumference of the hole as necessary to smooth out the surface.

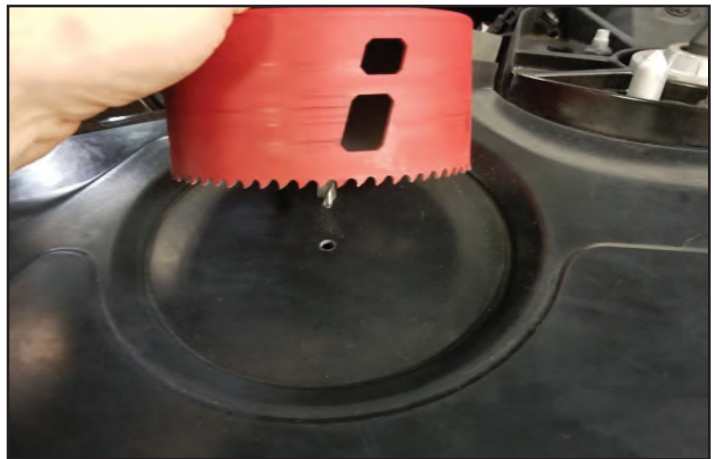

194. **Coupe Only:** Apply blue Loctite 242 and install (4) threaded hex adaptors PN 77-89-06-012 into the rivet inserts in the fill reservoir bracket as shown.



195. **Coupe Only:** Pre-install the fill reservoir cap onto the reservoir then install the reservoir sub-assembly from inside the LH rear wheel well with the hose nipples pointing toward the front.

Center the reservoir cap in the hole then secure the reservoir to the vehicle body using (4) black button head fasteners PN 72-06-10-021.

Apply blue Loctite 242 to the fasteners prior to installation.

Ensure the reservoir cap does not contact the edge of the fiberglass panel. Grind or sand the hole as necessary so the gap is uniform around the circumference of the cap.





## 196. Intercooler Tank Vent Hose Sub-Assembly

**Note:** The following slides detail installation of the hoses to the fill reservoir on coupe models. Installation is similar on convertible models, however, the fill reservoir is located inside the engine bay at the LH rear corner. Measure and cut hoses as appropriate for convertible models.

Cut a 5-inch long section of 3/8" coolant hose from the supplied 10-foot section.



## 197. Intercooler Tank Vent Hose

Install the hose onto the check valve P/N 68-12-57-107, ensuring the arrow on the valve is pointing TOWARD the hose end.

Secure the hose to the valve with a 19mm constant tension clamp from the kit.

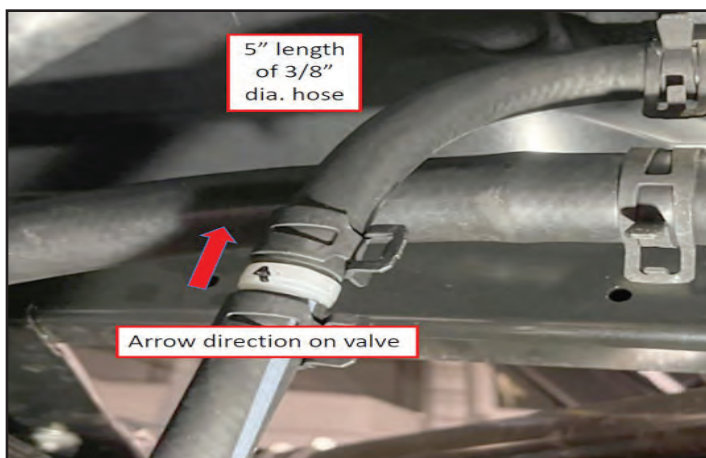

198. Working from inside the LH rear wheel well, route the remaining length of 3/8" coolant hose together with the other 3/4" hoses, inboard and down toward the tunnel. Secure it to the other hoses with zip ties, ensuring it is routed away from the exhaust system.

Install the check valve / hose sub-assembly that was fabricated in a previous slide onto the end of the long coolant bleed hose. Secure the hose to the check valve with a 19mm constant tension clamp from the kit.

The opposite end of the 5" hose installs onto the upper nipple on the coolant fill bottle. Secure the hose to the bottle with another 19mm constant tension clamp.

Ensure the hose does not dip and has a constant upward travel towards the reservoir. Zip tie/secure as necessary.

**Note:** Coupe hose routing shown. Convertible hose routing similar.

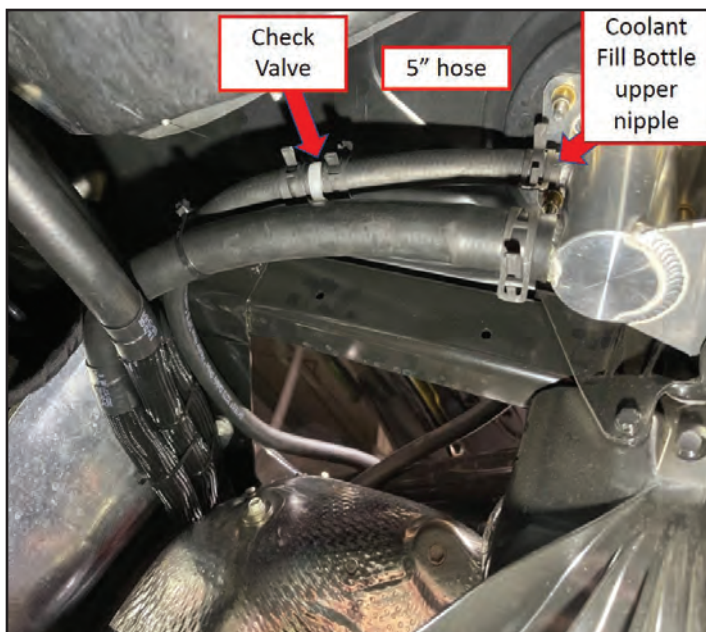

199. Install a 27mm constant tension clamp onto the end of coolant hose 087C then route and install the hose to the lower nipple of the fill bottle. Cut the hose to length if necessary.

Secure the hose using the clamp.

Zip tie the hoses together as shown.

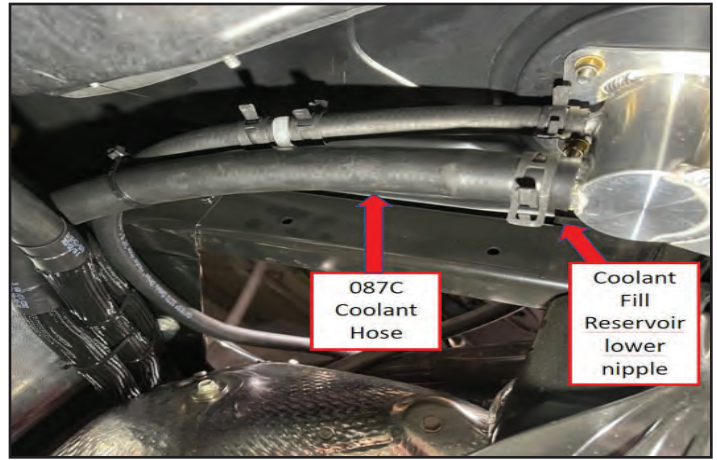

200. Re-install (2) main coolant lines in tunnel. Tighten (1) gear clamp and install (1) constant tension clamp @ main coolant tube connections.

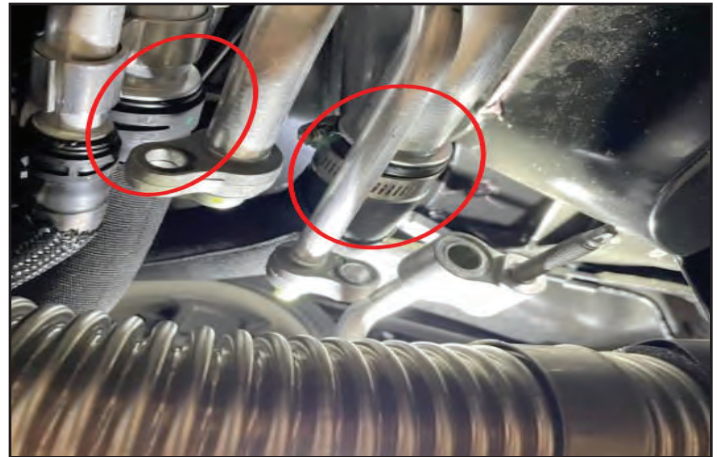

201. Re-connect rubber hose @ small aluminum tube. Fasten constant tension clamp.



202. Re-secure and tighten (2) AC tube connection nuts above the fuel crossover tube (if A/C lines were split).

**Torque to 16 ft-lbs.**





203. Pre-install fuel cross-over heat shield up into tunnel.

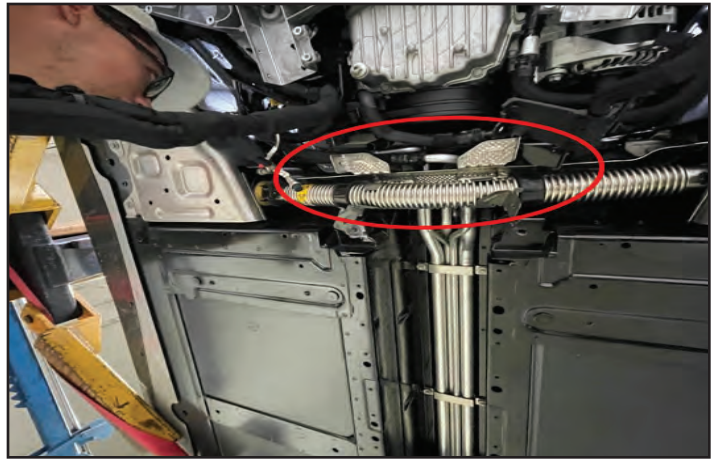

204. Install crossover heat shield push pins through heat shield into aluminum fuel tank shield.

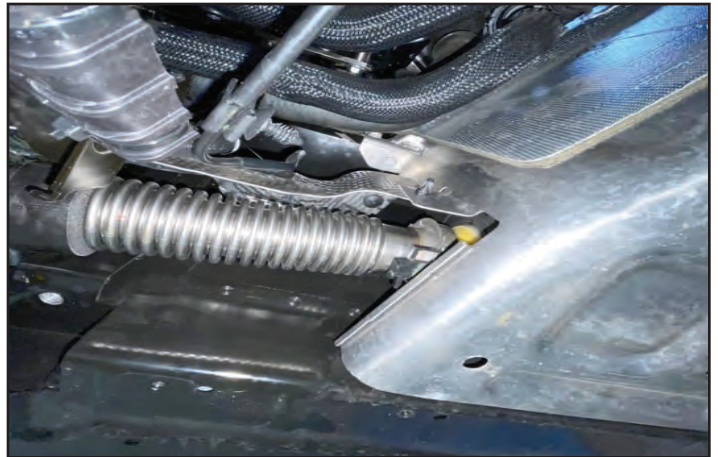

205. Apply Loctite and install LH / RH upper control arm bolts (4 per side). Longer bolts go in the outside locations.

Washers go between the control arm mounts and the frame.

Use a floor jack and piece of wood under the rotor to pre-load the rear suspension and allow the upper control arm bolts to go in easier. **HAND-START THE BOLTS, ENSURING YOU DO NOT CROSS-THREAD THEM.**

**Torque control arm bolts to 44 ft-lbs.**



206. **Convertible Only:** Re-install (2) nuts securing fuel line above RH exhaust manifold.

**Torque to 88 in-lbs.**



207. Install the 3/8" SAE connector found in the kit, (PN 48-46-00-072), onto the end of the 087L fuel vapor hose. Secure the connector with a 3/8" constant tension clamp then install the hose sub-assembly onto the vehicle side male tube as shown.

Harvest the spring clamp from the OE fuel vapor hose and install it over the 087L hose, then into the brace as shown.

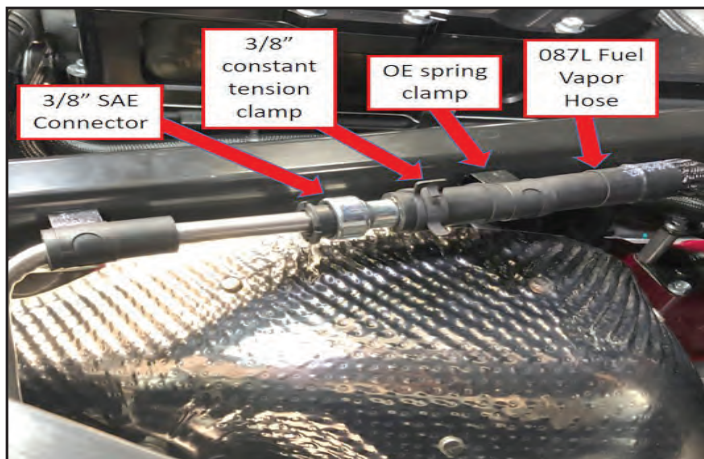

208. **Convertible Only:** Route and install the 087F coolant hose onto the top port of the factory reservoir. Secure it using a constant tension clamp.

Secure the 087F hose to the bracket on the RH side of the supercharger using zip ties.



209. Lubricate and re-install rubber exhaust hangers on LH / RH sides.



210. Reconnect NPP exhaust valve connectors @ LH / RH valves (if vehicle is equipped).





211. Reinstall (1) fastener @ coolant line bracket.

Pull coolant lines back outside the frame and re-attach.

Re-fasten fir tree connector.

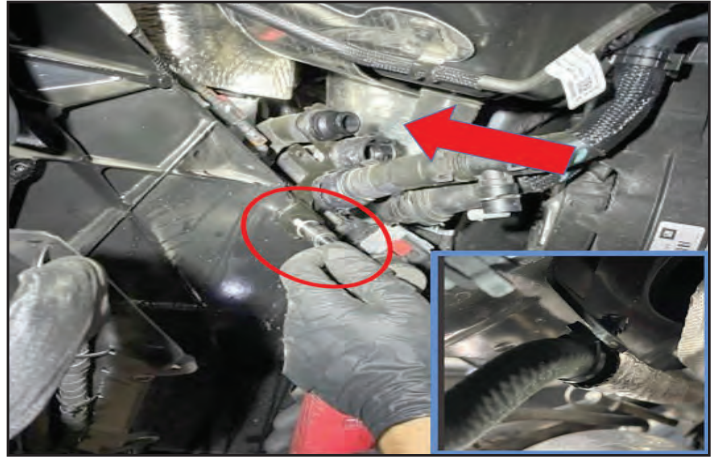

212. **Coupe Only:** Find the end of the previously installed 087F coolant hose and route it toward the female quick connector located in the front of the RH wheel well.

Cut the hose to length as required, then install the OE factory male connector that was previously harvested, onto the end of the 087F hose. Harvest the OE silver heat shield from the OE hose and install it over the 087F hose so it is located by the exhaust system, then install a 5/16" constant tension clamp to secure the male connector to the hose.

Connect the 087F hose sub-assembly to the OE 90-degree female connector.

Zip tie the 087F hose to the bracket and along the firewall to secure it as necessary.

Ensure the hose does not come into contact with any rotating or hot parts.

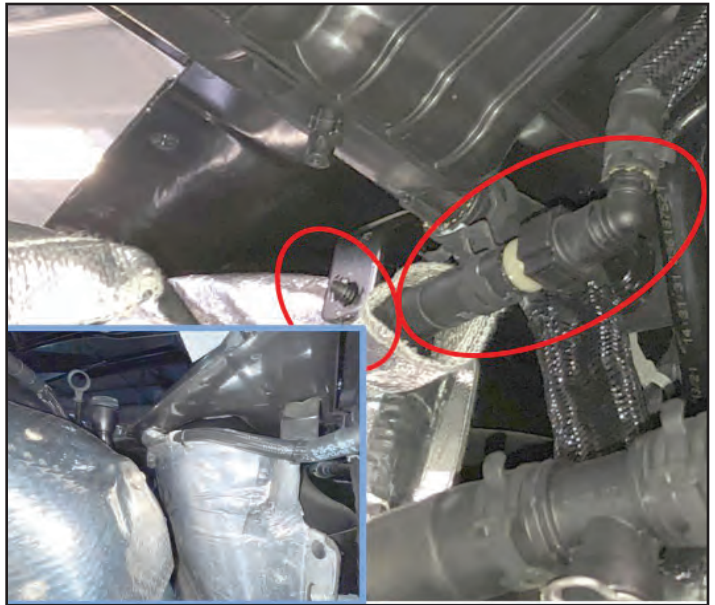

213. Re-install LH / RH crash blocks in front of upper control arms.

**Torque to 88 in-lbs.**



214. Inside the RH rear wheel well, re-secure fir tree connectors holding the main harness bundle to the bracket, frame structure and the coolant line bracket.

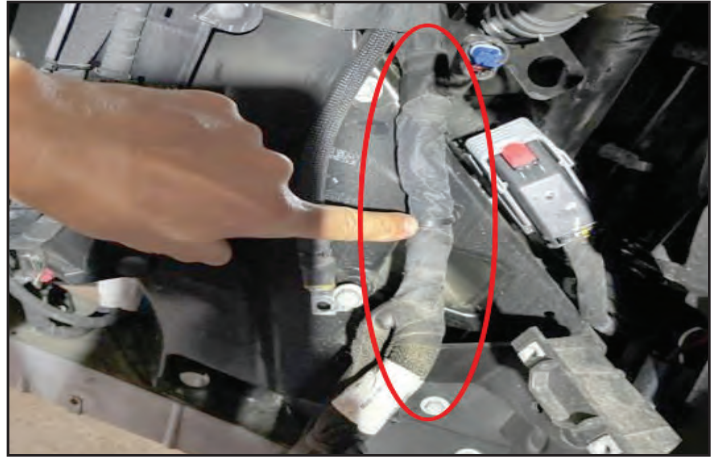

215. Inside RH rear wheel well, install hardshell connector into thermostat sensor.



216. Inside RH rear wheel well, re-install fastener securing chassis cable ground.

Re-install plastic harness bracket securing ground cable to chassis.



217. Re-connect LH / RH wheel speed sensor and accelerometer (if equipped) pigtails at connection points in front of the rear calipers.





218. LH side: Re-install (2) fir tree connectors holding plastic harness bracket to frame.

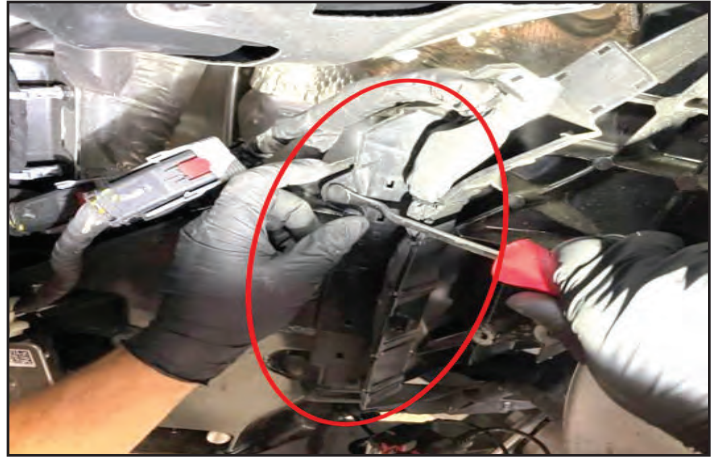

219. Re-install (2) bulkhead connectors inside LH rear wheel well.



220. Re-connect LH / RH parking brake harnesses to chassis retention points.

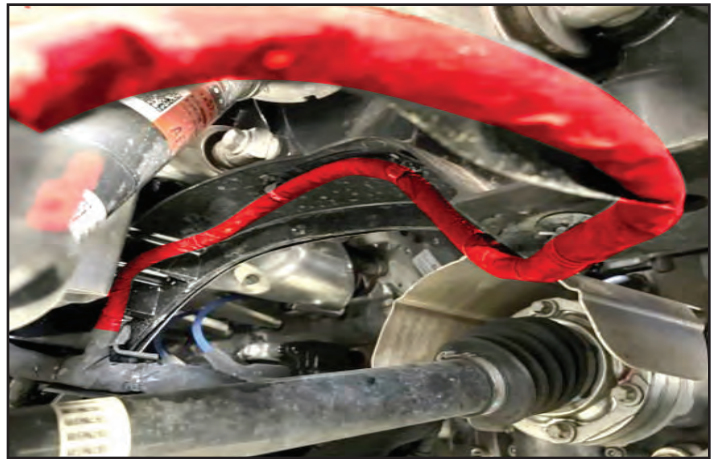

221. Re-install hard shell connectors @ LH / RH parking brake solenoids.



222. Re-install FTZM module into LH fender. Re-install all bracket fasteners.

Re-connect electrical connector to FTZM module.

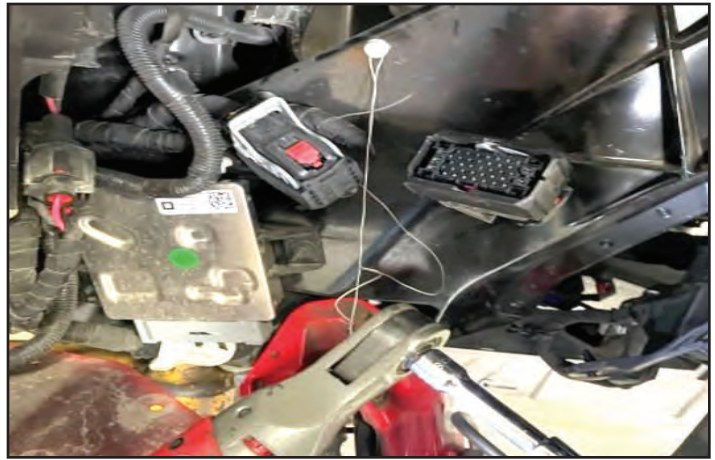

223. Inside the LH wheel well: route, secure and install the 087A and 087B hoses onto the Low-temp radiator and secure with 3/4" constant tension clamps.

**Note:** The hoses can be trimmed to length as needed to help keep them away from the exhaust heat shields.

**Note:** Hose 087A installs onto the front fitting.

\*\* **Convertible models:** See following slide for unique hose routing and installation detail \*\*

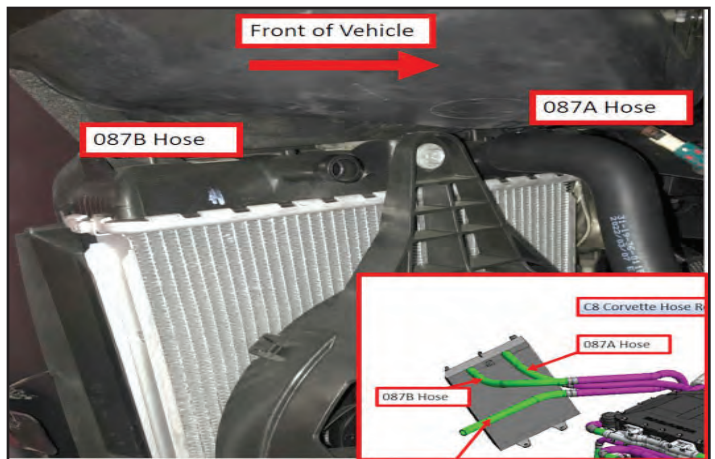

224. **Convertible Only:** Install a 3/4" constant tension clamp and 90 degree mender from the kit to the end of the 087A and B hoses. Secure the clamps in place.

Cut (2) short pieces of leftover 3/4" hose approximately 3 inches long. Secure each hose to the opposite end of the 90 degree mender, then install the hose sub-assemblies onto the low-temp radiator, securing them with 3/4" constant tension clamps.

**Note:** Hose 087A installs onto the front fitting.

See the following slide for convertible hose routing detail.

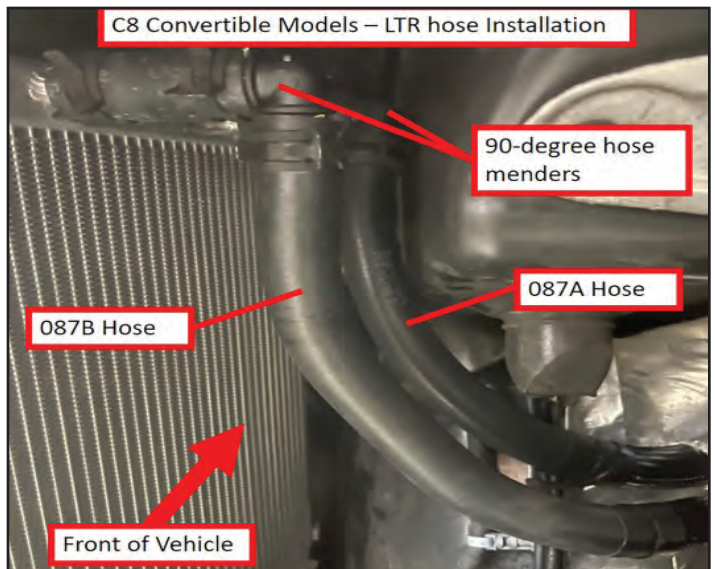



225. **Convertible Only:** Route the 087A and B hoses as shown. Install heat shielding material (not provided) in any areas that come in close proximity to the exhaust system as needed to protect the hoses from excessive heat. Install the piece of protective U-channel molding from the kit to the sharp body edge as shown to keep the hoses from chaffing. Tuck the hoses as close to the fire wall as possible. Use zip ties as necessary to hold them in place.

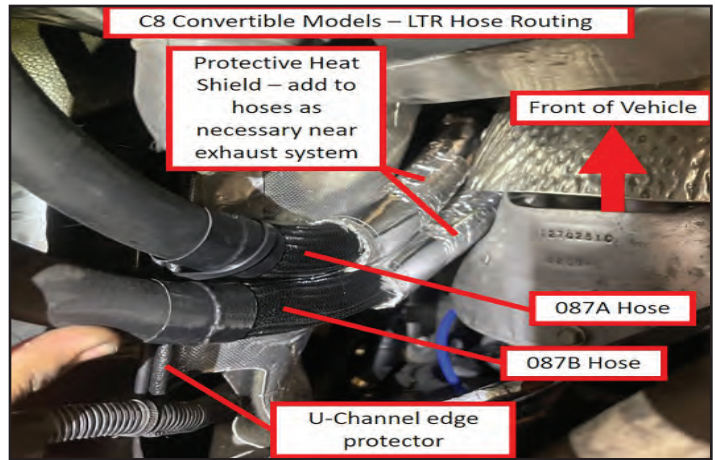

226. Re-install LH / RH rear calipers.

**Apply blue Loctite 242 and torque caliper bolts to 118 ft-lbs.**



227. Re-install brake line bracket fasteners into LH / RH control arms.



228. Re-connect the fuel line at LH side by tunnel.

Re-install the lock.



229. Re-connect B+ fir tree connector into the bracket by the alternator.



230. Re-install and tighten (2) nuts securing the positive battery cable to the alternator.

Re-connect the positive battery cable cover @ alternator.



231. Re-connect hardshell connector @ A/C pressure sensor.



232. Re-install the ECM bracket into the tunnel (early models).

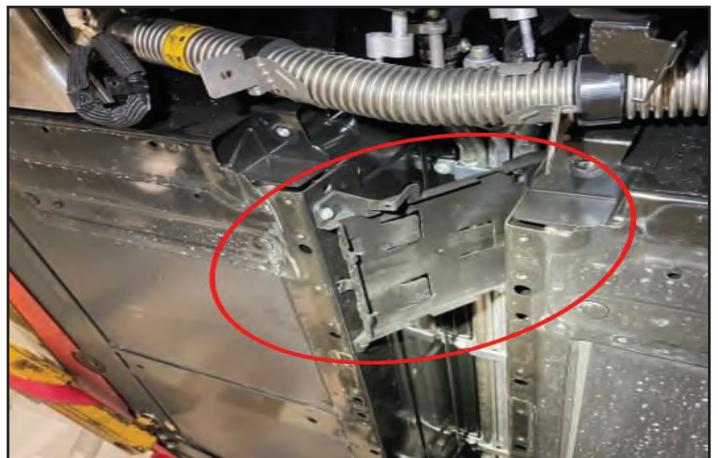



233. Re-install the ECM into the tunnel bracket (early model shown).

Re-connect (4) electrical connectors @ ECM.

Late models – ECM located inside LH rear fender.

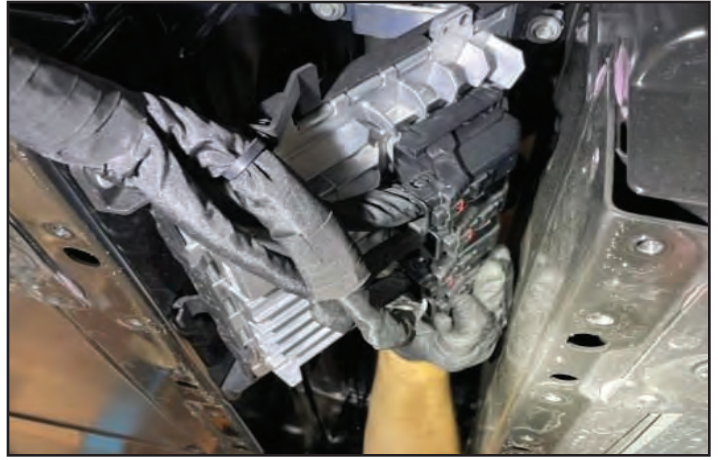

234. Ensure coolant line connection has been made and constant tension clamp has been installed by alternator.



235. Inside RH fender, ensure the radiator drain plug has been installed and tightened.

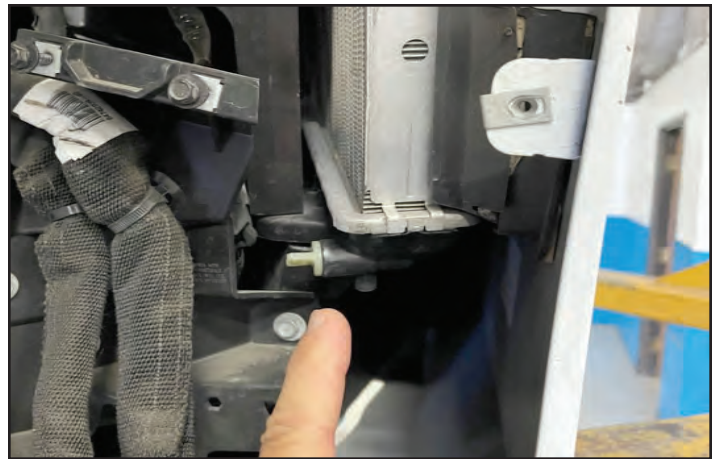

236. Re-install the TCM bracket then install/ tighten the fasteners securing the bracket to the vehicle.

Re-install the wiring harness fir tree connectors into the plastic TCM bracket.



237. Re-connect the Trans Control Module (TCM) electrical connectors.



238. Re-install LH and RH brake lines into plastic holders at cradle.



239. Apply blue Loctite 242 to all bolts.

Re-install the LH and RH frame braces into the vehicle. Re-install and zero torque all frame brace bolts. **Pre-torque all horizontal bolts (red circles) 43 ft-lbs. then apply + 100 degrees final angle.**

Large vertical bolts (blue circles) are to be pre-installed and run up to within  $\frac{1}{2}$  inch of contact with brace. They will be final torqued to 118 ft. lbs. after the underbelly covers have been installed.



240. Re-install fasteners holding the brake line brackets and heat shields into the LH and RH aluminum frame braces by the fuel cross-over.

Re-install (4) push pins securing the fuel cross-over heat shield.

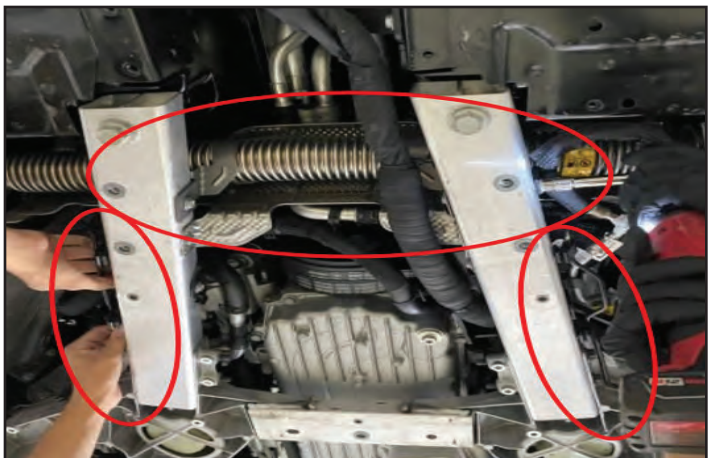



241. **Install and torque upper shock mount nuts 22 ft-lbs. (3 per side) on LH / RH sides.**

Re-connect mag ride sensors and clip sensor to the bracket on the vehicle.



242. Route the 087L fuel vapor line along the RH engine brace, toward the OE connection point at the frame brace.

Cut the 087L hose to length as necessary, then install a 3/8" constant tension clamp over the hose, followed by a 3/8" SAE metal barbed fitting (P/N 48-46-00-072).

Slide the clamp up the hose to secure the barbed fitting.

Re-install the purge line clip to the body brace.

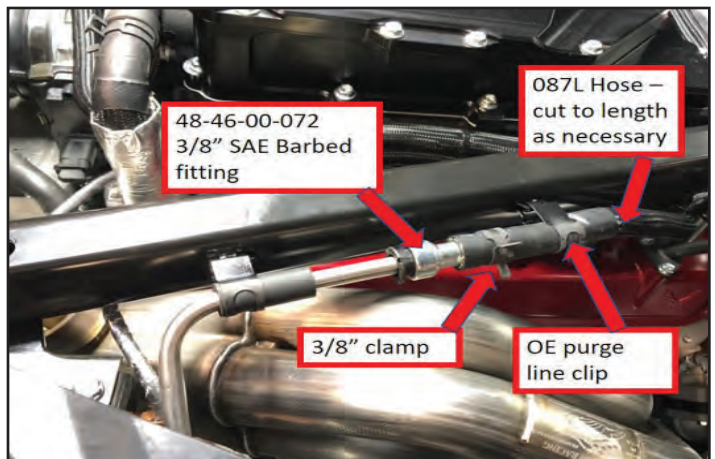

243. **Coupe Only:** Use double-faced tape to secure the relocation module to the location shown.

Any extra relocation module wiring can be routed under the vehicle cross support and zip tied to adjacent factory wiring near the air box. Ensure the wiring is kept as far away from the exhaust system as possible.

**Convertible Only:** Relocation module can be secured under cross support or against front of airbox as appropriate. Ensure the module and wiring are kept as far away from the exhaust system as possible.



244. **Convertible Only:** Route the 087E hose across the back of the supercharger as shown. Ensure it is attached and clamped to the bottom port on the LH side of the factory reservoir.

Use zip ties to secure the hose along the RH side of the supercharger.





245. Re-install the LH / RH air inlet ducts (4 fasteners per side) and tighten the fasteners.

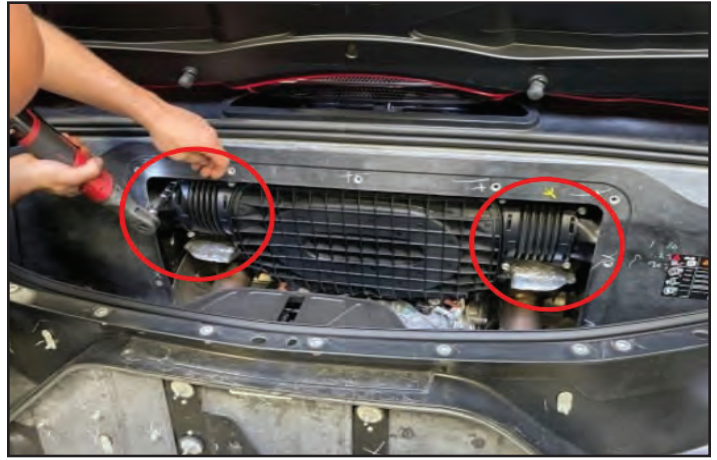

246. With help from a second person, gently lift and begin to re-install the rear fascia onto the vehicle.

While holding the fascia close to the vehicle, re-connect (3) electrical connectors between body and fascia.

Install (2) rear fascia screws loosely to hold it in place.



247. Facing rearward from inside each rear fender, locate and re-install the fasteners attaching the rear fascia to the LH / RH fenders @ rear upper corners.



248. Re-install the LH / RH rear inner fender panels. Secure using the original Torx T15 screws. **Torque to 22 in-lbs.** Install push pins.

Re-install the plastic rock guards onto the LH / RH rear corners of wheel wells (bottom right photo).





249. Re-install fasteners in upper LH / RH corners securing rear valence to rear fenders.



250. Re-install rear lower under body valence and rear brake cooling ducts, if applicable.

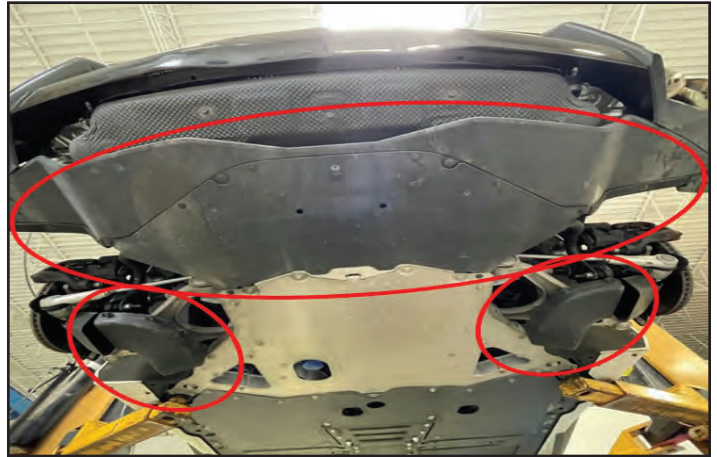

251. Re-install rear wheels.

**Torque lug nuts to 140 ft-lbs.**



252. Re-install shims (as applicable per original OE installation) and screws around perimeter of rear upper valence.

**Torque screws to 22 in-lbs.**

Remove grease pencil markings made during removal process noting shim locations.



253. Re-install front closure panel then install and tighten fasteners around perimeter of panel.

Re-install carpet in trunk.



### Section 3: Charge Air Cooler Pump/ Electrical Upfit

#### 254. **Charge Air Cooler (CAC) Pump Electrical System**

The following slides detail the electrical upgrades required to support the operation of the CAC electrical pump.

Gather the relay harness assembly P/N 82-55-80-078 shown here.



#### 255. **Intercooler Relay Harness Modification:**

Install the 15A fuse inside the fuse holder of the relay harness assembly from the last step. Pull the yellow wire out of the existing convolute and cut the existing fuse tap lead off. Add 6.5 feet of additional yellow wire to the existing harness.

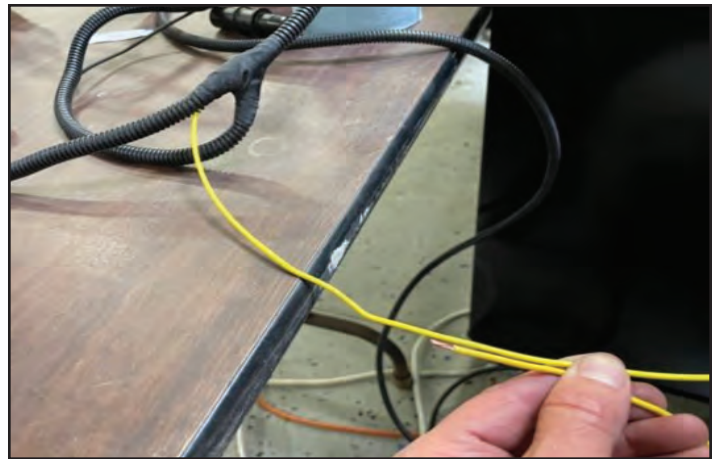

256. Solder and heat shrink the connection, then install the supplied convolute tubing over the yellow wire.

Re-install the fuse tap lead to the end of the 6.5-foot wire extension and solder/heat shrink the end.

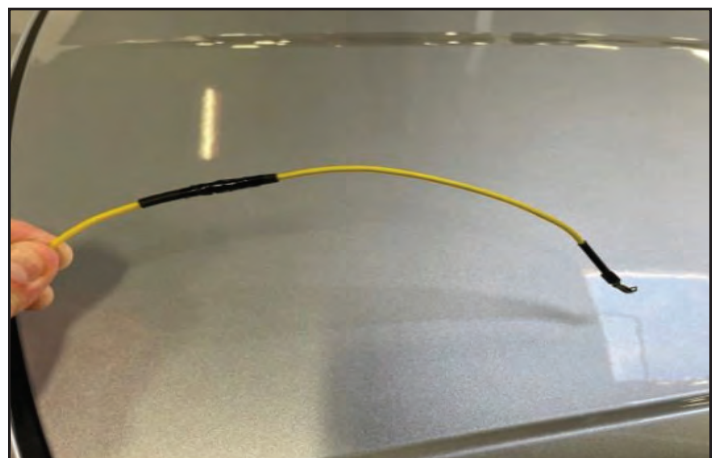



257. Install intercooler pump relay and fuse under hood in the area shown.

Add convolute tubing to all wires then tape ends with Tesa or electrical tape.

Secure both components with a nut then route all wiring behind the battery and down toward the tunnel.

Raise the vehicle and continue with installation on the following step.

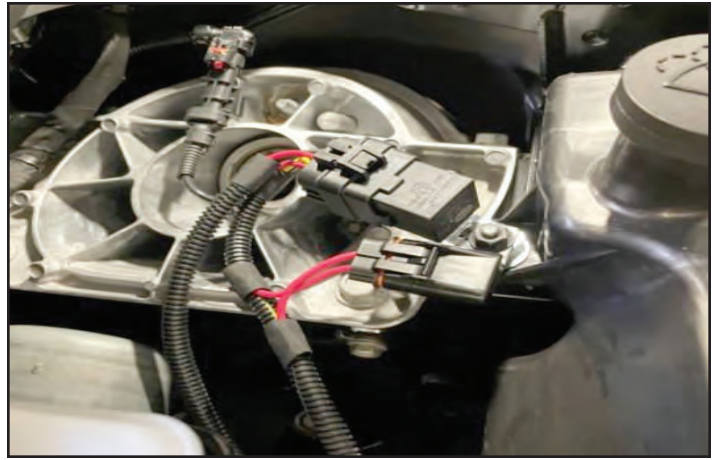

258. Route the positive and negative CAC pump relay wires up into the battery compartment. Crimp ring terminals onto the positive and negative wires (if not installed).

Fasten the red (+) wire to the red positive battery terminal by installing an M6 flanged nut from the kit to the factory stud.

Remove the factory nut from the negative (black) battery terminal then install the black wire onto the stud and re-secure with the factory nut.

Install wire loom over the red and black wires and secure as necessary with zip ties.

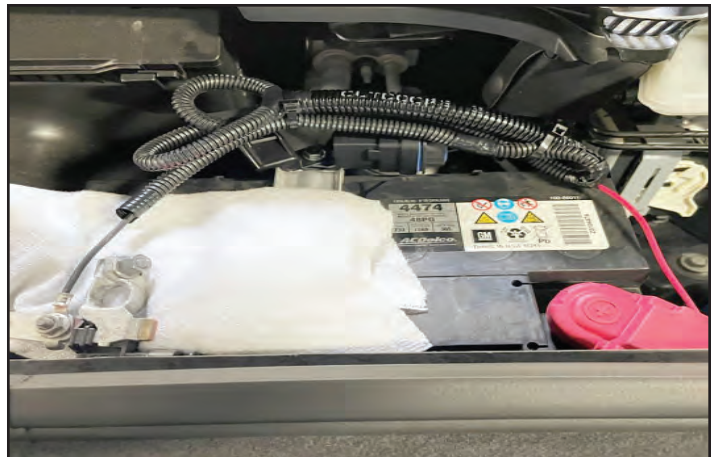

259. Ensure the (3) tunnel tube brackets are installed. Re-install into top of tunnel as necessary.



260. Route the yellow wire down through the tunnel and into the body plug located along the LH vertical face of the tunnel.

Zip tie the wire along the coolant lines ensuring it does not rub on any sharp surfaces.

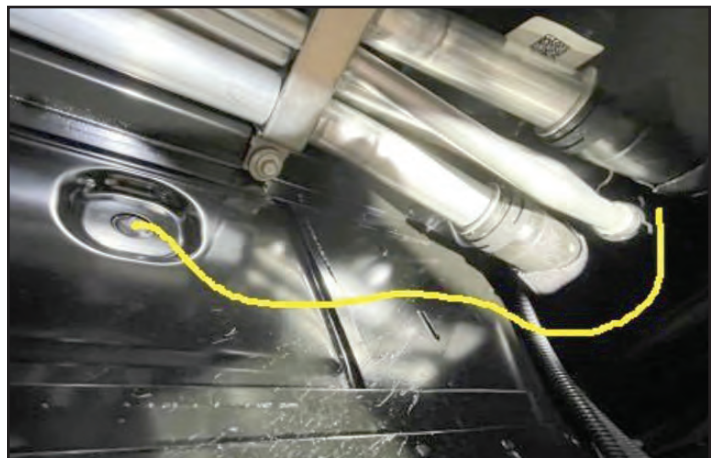

## Section 4: Tunnel Reservoir Installation

### 261. Tunnel Reservoir (Intercooler Tank) Sub-Assembly

See Appendix B for specific hose routing detail.

Select Tunnel Reservoir P/N 68-01-03-083. Apply pipe sealant and install a 1/8" NPT to 3/8" barb fitting P/N 48-46-00-009 onto the reservoir.

Install the remaining 9 1/2 foot long piece of 3/8" hose onto the intercooler tank barbed fitting and secure with a 3/8" constant tension clamp.

Route the hose along the top of the tank as shown.



262. Route the intercooler pump wiring harness and the coolant bleed hose above the tank, toward the back of the car, in between the intercooler tank stand offs. Ensure the wiring and coolant line do not become pinched as you install the tank into the vehicle.

Apply blue Loctite 242 and secure the tank to the vehicle using the original fasteners.

Secure the hose and all wiring in place with zip ties. Loop any extra length of wire in front of the reservoir and secure to the OE tunnel tubes with a zip tie.

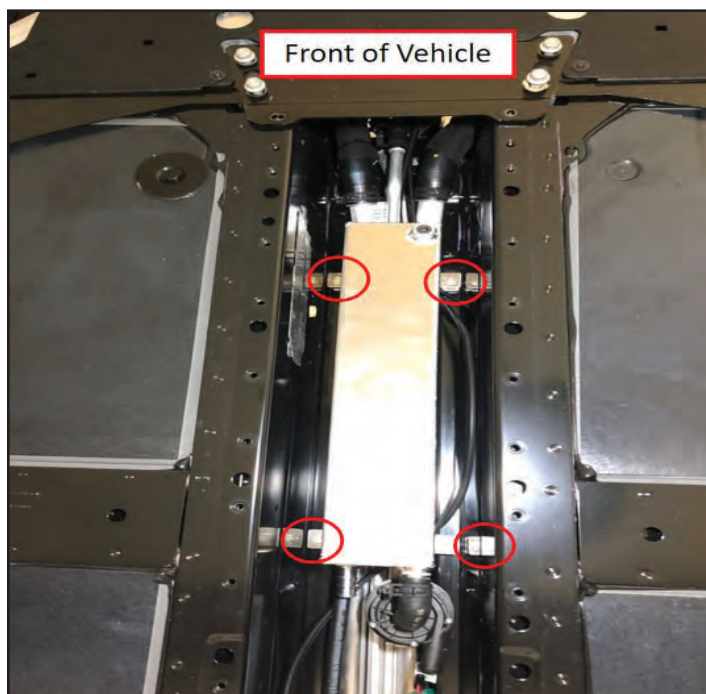

263. Install intercooler pump P/N 68-14-59-005 onto rear of tank using worm gear clamp P/N 48-46-10-018, with the pump oriented as shown in the photo.

Tighten the clamp securely over the rubber isolator.

Install 3/4" constant tension clamps over both ends of Hose P/N 31-26-62-087D, then install the hose between the pump and tank as shown. Slide the constant tension clamps toward the hose ends to secure the hose to the tubes.

Select wiring harness pigtail adaptor P/N 82-55-80-087 and connect it to the pump, then connect harness P/N 82-55-80-077 to the adaptor.

Secure the pump wiring with zip ties along the tunnel as required.

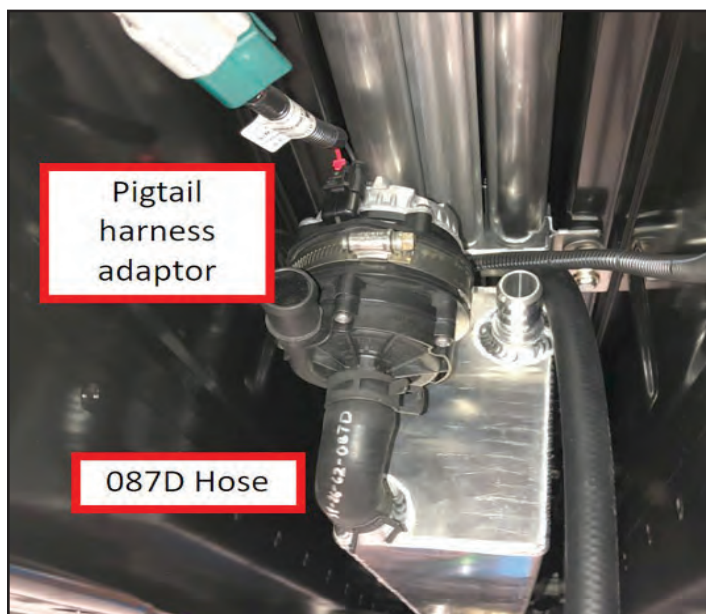



264. Route, secure and install hoses 087B and 087C toward the intercooler pump and reservoir. Cut the hoses to length as necessary for proper fitment within the tunnel. Hose 087B installs onto the intercooler pump. Secure with a  $\frac{3}{4}$ " constant tension clamp.

Hose 087C installs onto the intercooler reservoir. Secure with a  $\frac{3}{4}$ " constant tension clamp.

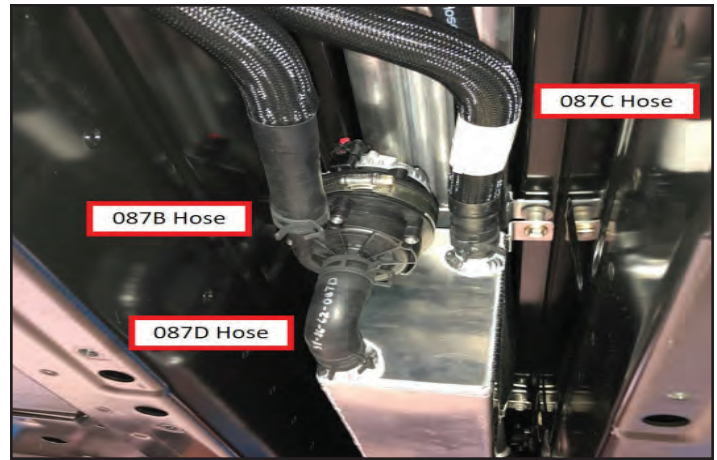

265. Secure the intercooler pump hoses to the factory tubes by using zip ties along the length of the tunnel as shown.

Ensure none of the lines rub on any mating components.



266. Working from inside the vehicle:  
Pull the LH side console trim panel outward toward the drivers' seat to gain access for routing the yellow wire. Find the yellow wire that was pushed through the tunnel in the earlier step. Install convolute tubing over the yellow wire, tape the ends then carefully route the yellow wire rearward inside the trim panel toward the fuse box located below the center speaker.



267. Locate the rear compartment fuse block in between the seats.

Remove the cover and set aside. It will need to be modified in the following slides.



268. Remove the 15A fuse at location 35 (ECM/ MAF/02/AC feed) then install the fuse tap for the CAC pump into the inboard side of the fuse at this location.

Re-install the original fuse into the fuse block tap.



269. Carefully route the CAC pump wire through the fuse box as shown.



270. Grind a notch in the fuse box cover in the location shown to allow the CAC pump wire to pass through.

Re-install the cover and all interior trim as necessary.

Continue to next page.

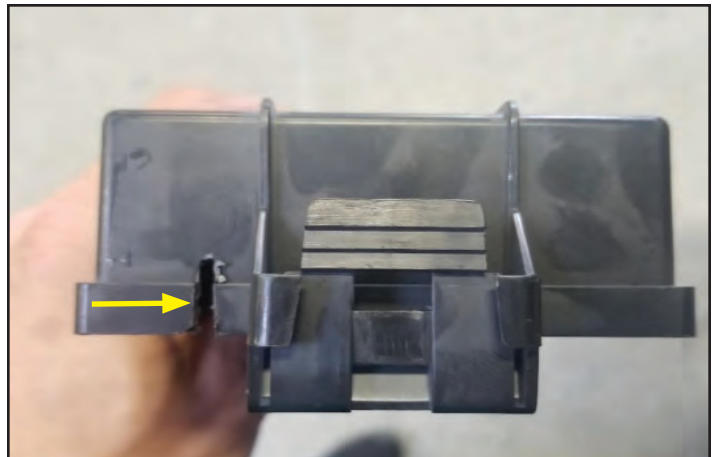



## Section 5: Coolant System Evac and Fill

### 271. **Coolant Systems Evac and Fill:**

Verify all coolant hose connections then proceed to evacuate and fill the engine and charge air coolant systems using Snap-On SVTSRAD272A vacuum/fill tool.

Fill the engine and CAC coolant systems with AC Delco Dexcool 50/50 Premix Antifreeze (GM P/N 10-5027 or 12378390).

**IMPORTANT:** the engine and charge air coolant systems **MUST** be vacuum bled in order to remove sufficient trapped air. Failure to use vacuum bleeding equipment may result in engine damage due to entrapped air.

In addition, the intercooler pump includes an internal fail-safe to prevent operation if it senses excessive cavitation or is run in a dry environment.

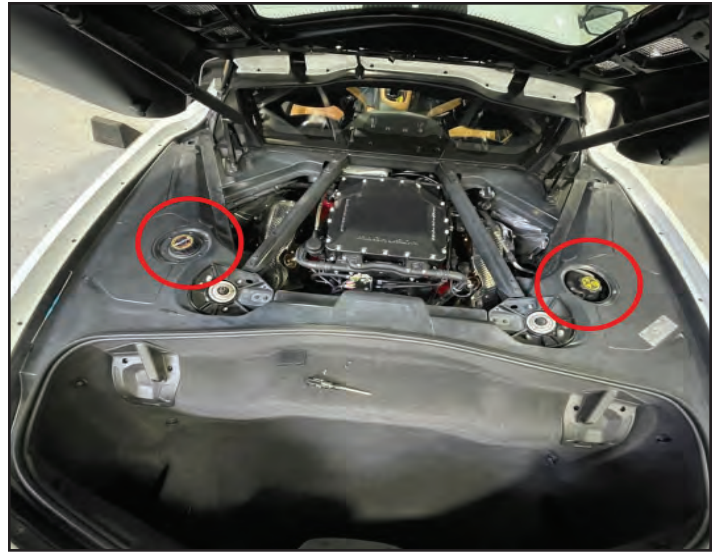

272. Verify battery cable connection is clean, re-connect and tighten the negative battery cable under the hood.



## Section 6: Flash ECM with Magnuson Calibration

273. Prepare to flash the new Magnuson calibration file to the vehicle.

It is strongly recommended to connect a battery charger to the vehicle whenever flashing a cal file.

If the flash process is interrupted at any point, you could permanently damage your ECM. Connect your MPVi3 to the OBDII port on your vehicle.

Connect the USB cable between the MPVi3 and your laptop.



274. Launch the HP Tuners **VCM Editor** software.

Click the File tab, then Open.

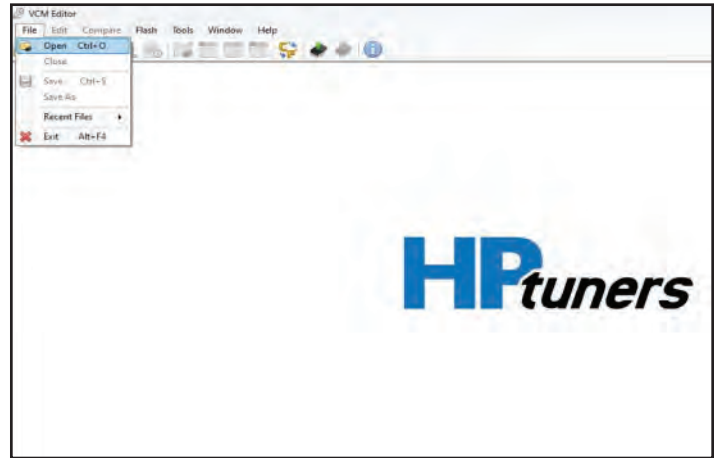

275. Navigate to the file folder where you saved the cal file that you have received from Magnuson for your specific application.

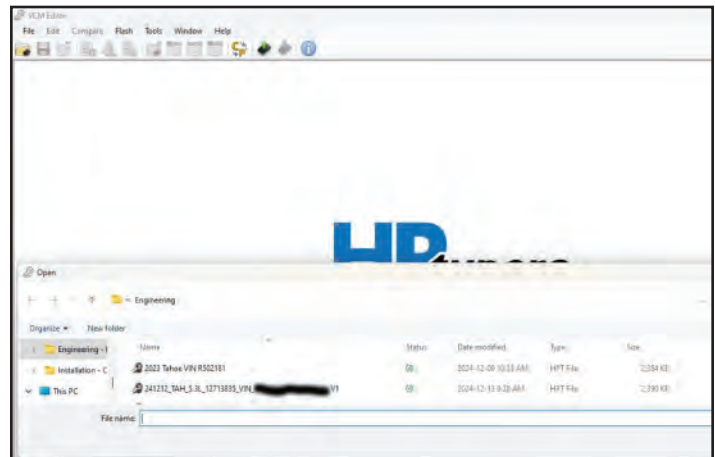

276. Click the Flash tab, then Write Vehicle.

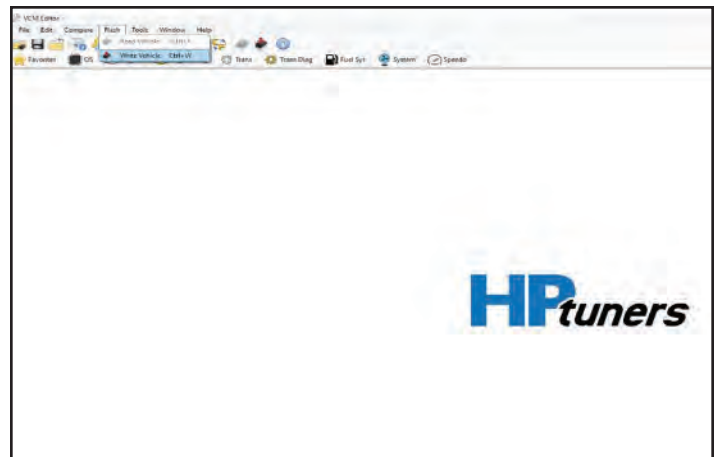

277. When the pop-up appears, click Write to begin flashing the vehicle.

\* At this point, HP Tuners will ask you to license the VIN. You are responsible to purchase the credits required to flash the calibration file to your vehicle.

Do not disturb the laptop or cables while the file is being uploaded to the vehicles' ECM. Allow the software to finish the process. Follow the on-screen prompts to cycle the ignition as requested.

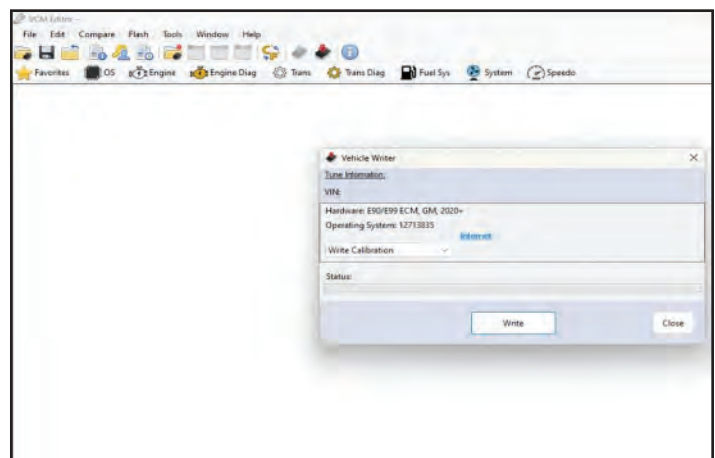



278. At this point your ECM should now have the revised calibration file loaded and the vehicle should be ready to start.

**\*\*\*A throttle body relearn is recommended. This can be done with some aftermarket service tools or the GM factory service tool.**

Make one final inspection of the entire under hood area, ensuring you have completed all steps of this manual, all tools have been cleared away and both coolant systems have been filled.

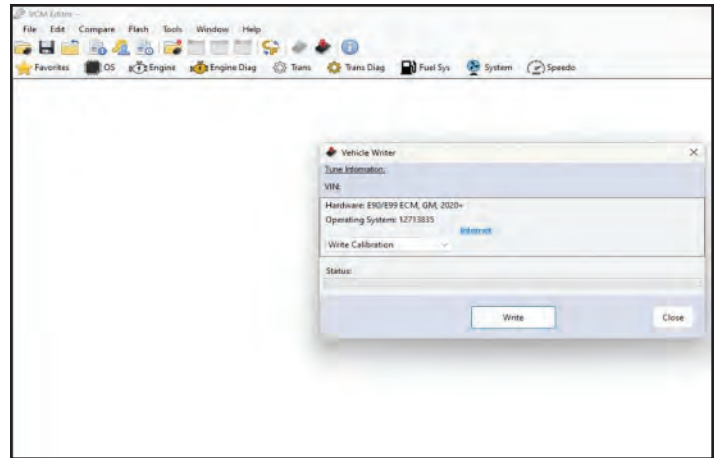

279. Make any final checks to the vehicle as necessary.

Start vehicle and check for any leaks or abnormal noises.

Perform final audit checks of coolant fill levels and wheel torques before driving the vehicle.



280. Road test / dyno the vehicle then inspect the entire under carriage for leaks before installing the under body panels. Working from under the vehicle, re-install (4) under body panels in the center of chassis, in the order shown in the photo. Hand-start ALL under-body fasteners first. Torque under body bolts, starting from the center and working your way outboard to the ends.

**M6 bolts are torqued to 80 in-lbs.  
M8 bolts are torqued to 16 ft-lbs.**

**IMPORTANT: Large tunnel panel reinforcement plate (steel plate) bolts are to be torqued to 118 ft-lbs.**

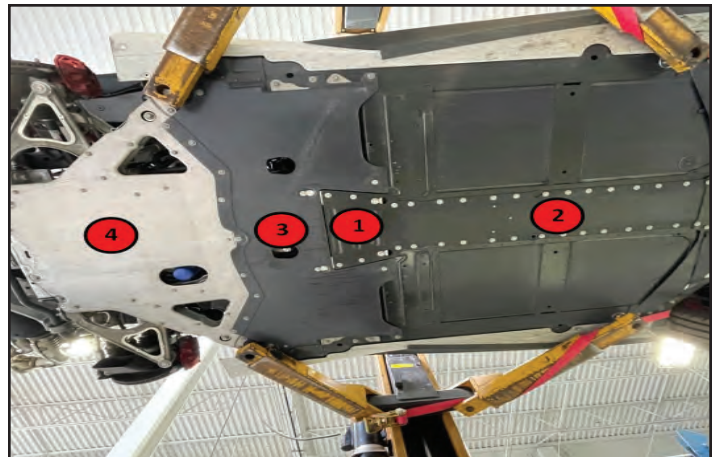

## Section 7: Convertible Model Addendum

281. **Convertible Only:** Prior to re-installation of the factory engine bay cover, the following modifications need to be made:  
Drill out the factory-installed rivet in the center of the engine bay cover using a 3/16" drill

See next step.

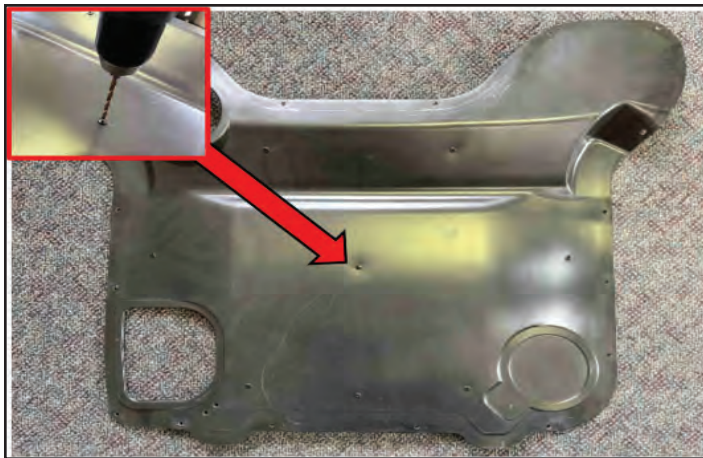

282. **Convertible Only:** Apply red Loctite and install a barrel nut assembly and 1-inch washer from the kit. Install the nut end of the assembly into the hole from the top side of the engine bay cover. Thread the screw/washer sub-assembly into the nut from the underside (heat shield) of the cover. Using a flat blade screwdriver, gently tighten the screw, ensuring the washer centers and engages onto the barrel nut. Tighten the screw only until the top surface of the washer becomes flush with the heat shield material.

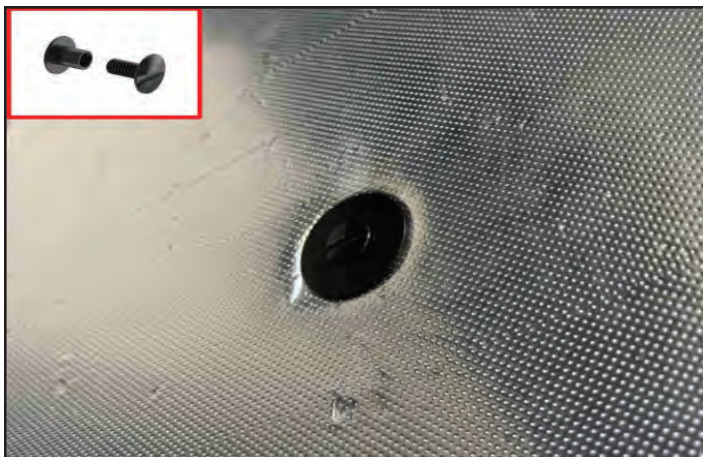

283. **Convertible Only:** It is recommended to remove all badges from the supercharger lid prior to re-installation of the factory convertible engine bay cover.

The badges have insufficient clearance to the heat shield and will result in contact during engine operation.



284. **Convertible Only:** With a helper, re-install the closure cover.

Re-install the fasteners around the perimeter of the engine access cover.





285. Print and install hang tag inside vehicle notifying customer they must **DECLINE** any future over-the-air (OTA) software updates from GM on this vehicle.

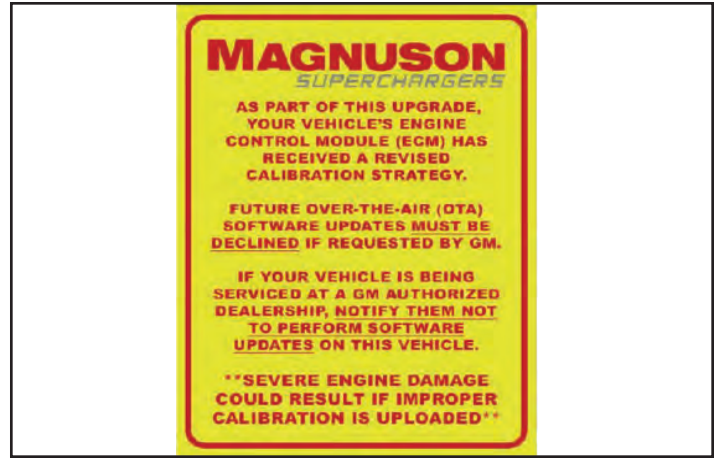

## Appendix A: Hose Part # Matrix

## C8 Corvette Hose Part # Matrix

| <b>COOLANT HOSES</b>  | <b>PART #</b> | <b>CLAMP SIZE / QTY.</b>           |
|---|---------------|------------------------------------|
| IC HOSE – LOW TEMP RAD TO SC INLET                              | 31-26-62-087A | 3/4 INCH / QTY. 2                  |
| IC HOSE – PUMP TO LOW TEMP RAD                                  | 31-26-62-087B | 3/4 INCH / QTY.2                   |
| IC HOSE ASSY – SERVICE FILL/SC OUTLET TO RESERVOIR (3-PC. HOSE) | 31-26-62-087C | 3/4 INCH / QTY. 3                  |
| IC HOSE – RESERVOIR TO PUMP                                     | 31-26-62-087D | 3/4 INCH / QTY. 2                  |
| HOSE – BTM DEGAS TO WTR PUMP (CONV. ONLY)                       | 31-26-62-087E | 3/4 INCH / QTY. 2                  |
| HOSE – WATER PUMP BREATHER TO DEGAS BOTTLE                      | 31-26-62-087F | 5/16 INCH / QTY. 2                 |
| <b>PCV HOSES</b>  | <b>PART #</b> | <b>CLAMP SIZE / QTY.</b>           |
| FRESH AIR SIDE  | 31-26-62-087G | 3/8 INCH / QTY. 2                  |
| VACUUM, DIRTY SIDE  | 31-26-62-087H | 3/8 INCH / QTY. 2                  |
| FRONT CROSSOVER   | 31-26-62-087J | 1/2 INCH / QTY. 2                  |
| <b>FUEL VAPOR HOSES</b>   |               | <b>CLAMP SIZE / QTY.</b>           |
| FUEL TANK VAPOR CROSSOVER                                       | 31-26-62-087K | 5/8 INCH / QTY. 2                  |
| VMV – BODY LINE TO VALVE  | 31-26-62-087L | 3/8 INCH / QTY. 2                  |
| <b>CLEAN AIR TUBE</b>   |               | <b>CLAMP SIZE / QTY.</b>           |
| CLEAN AIR TUBE  | 31-26-62-087M | 1.25" OETIKER AND 120mm WORM DRIVE |



# Appendix B: Hose Routing Detail

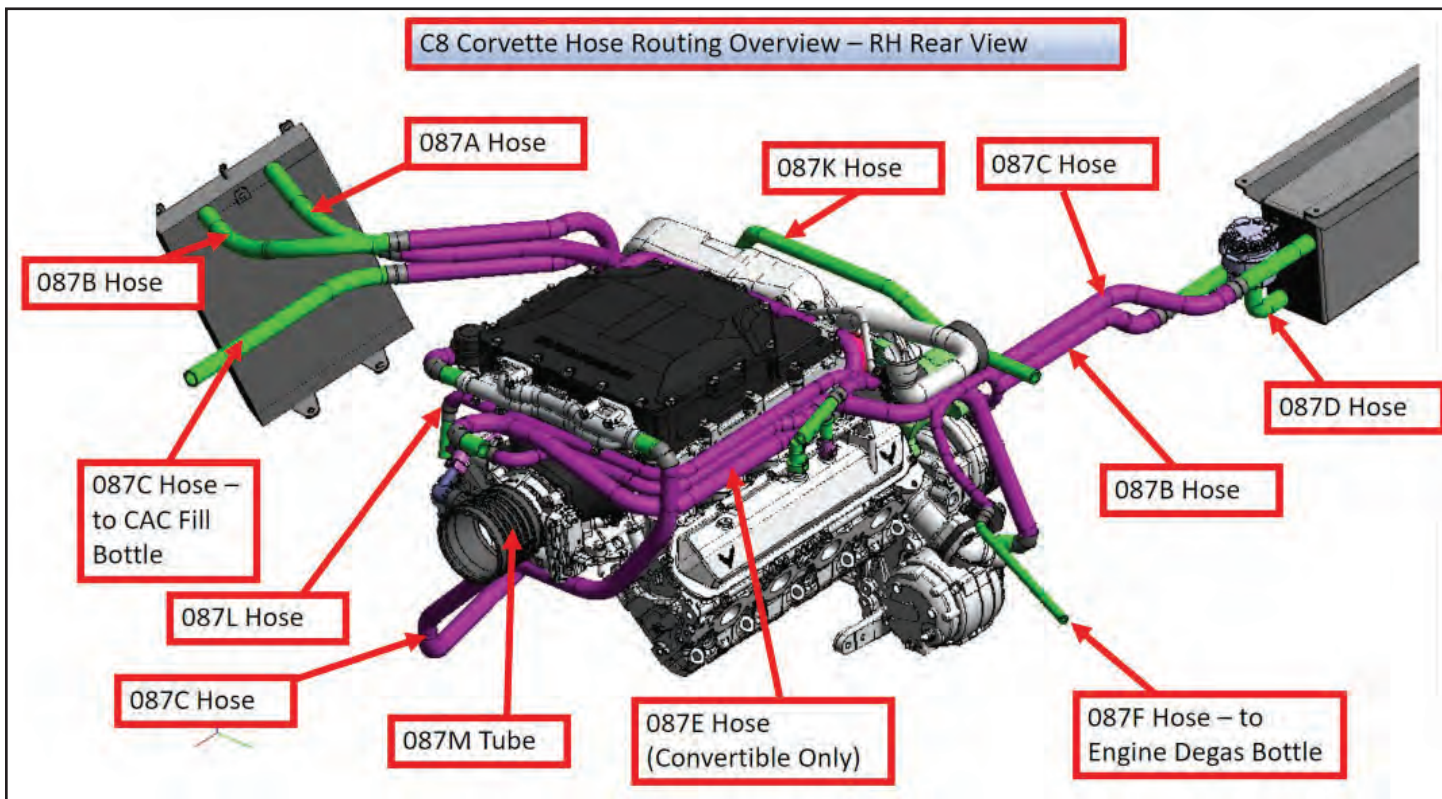
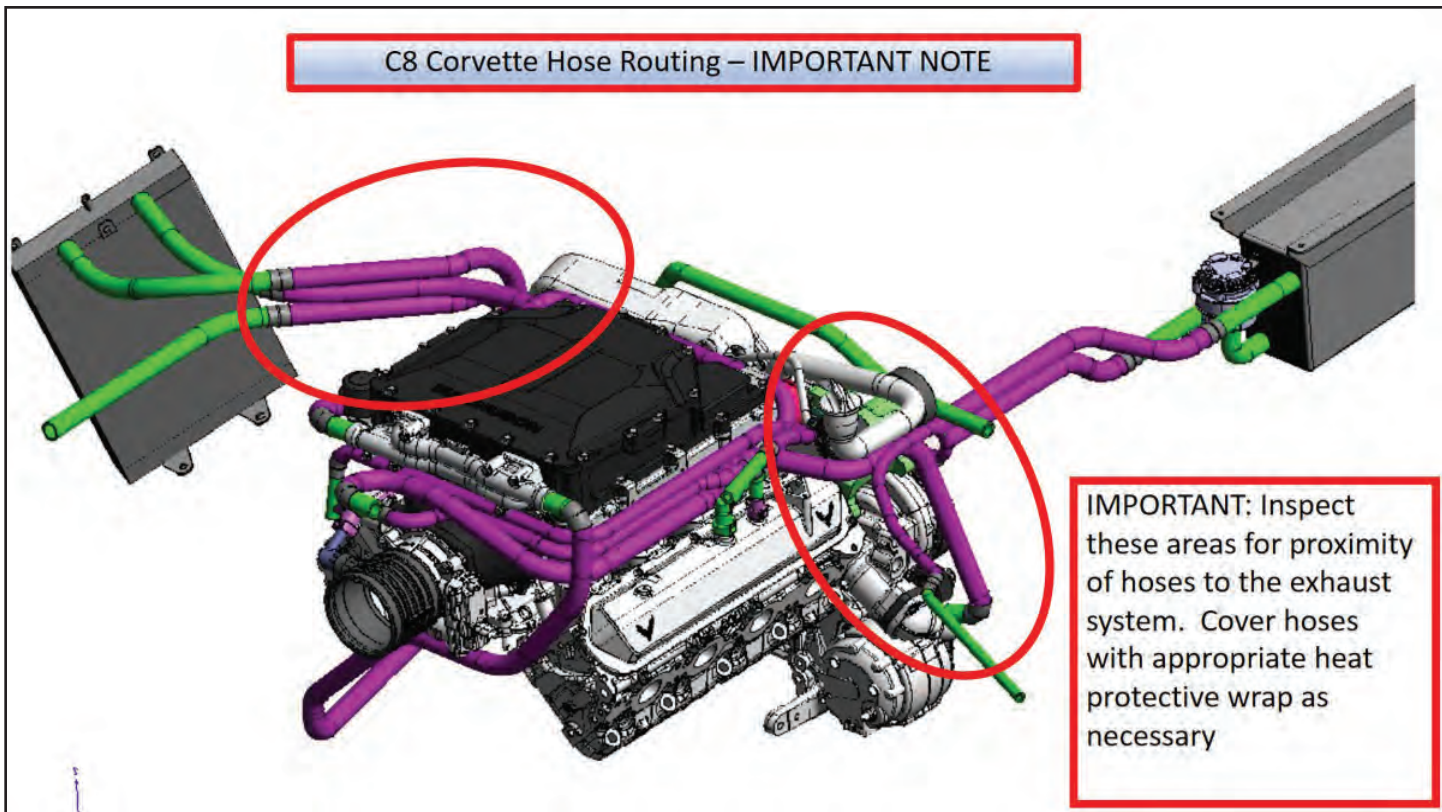



C8 Corvette Hose Routing Overview – RH Side View

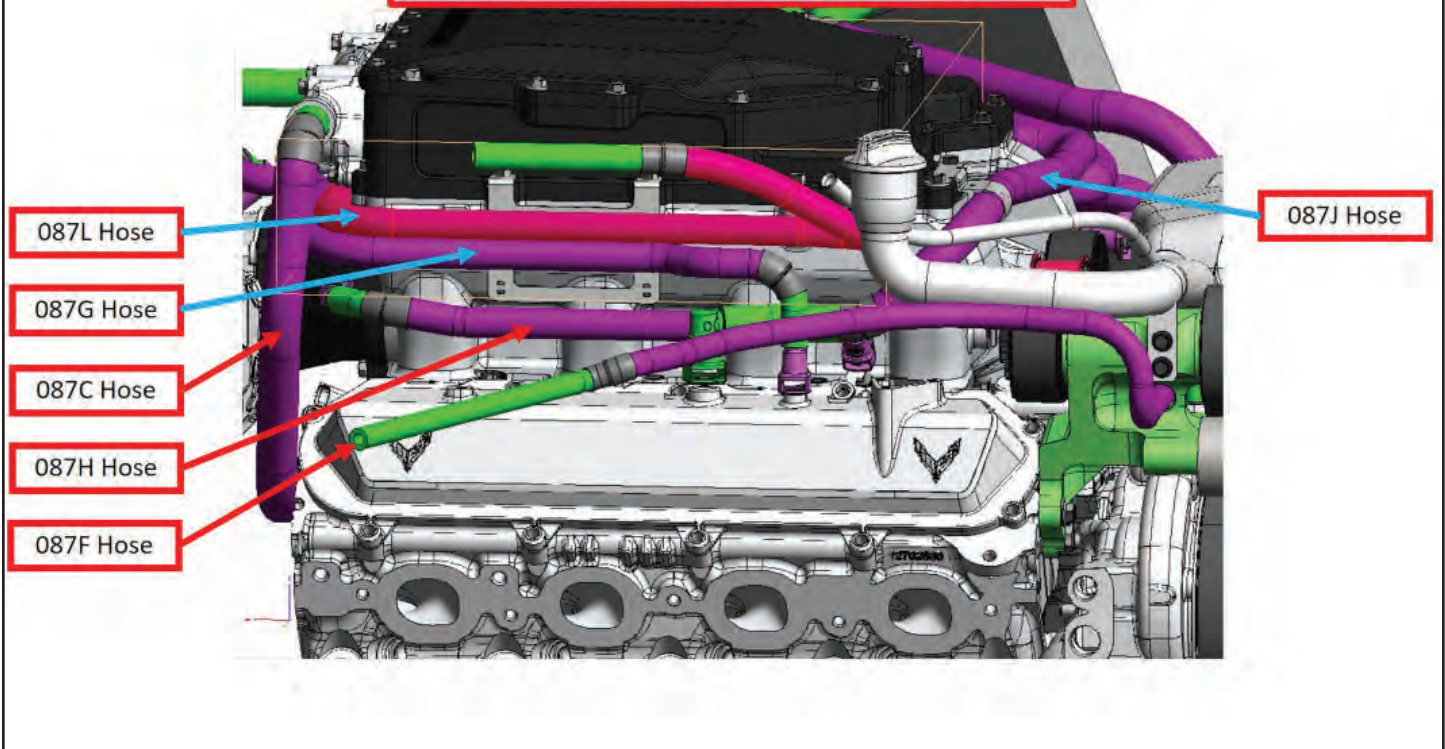

C8 Corvette Hose Routing Overview – RH Front View

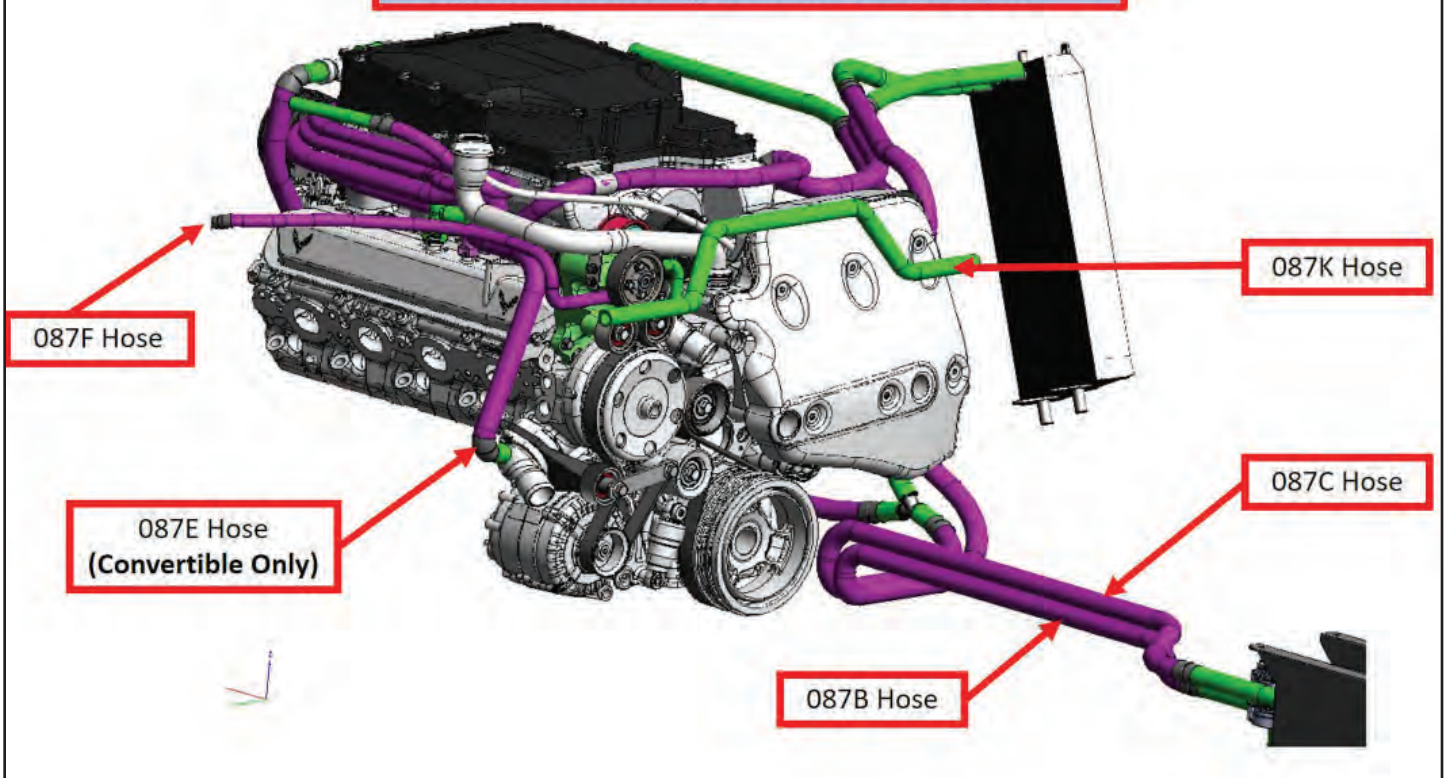



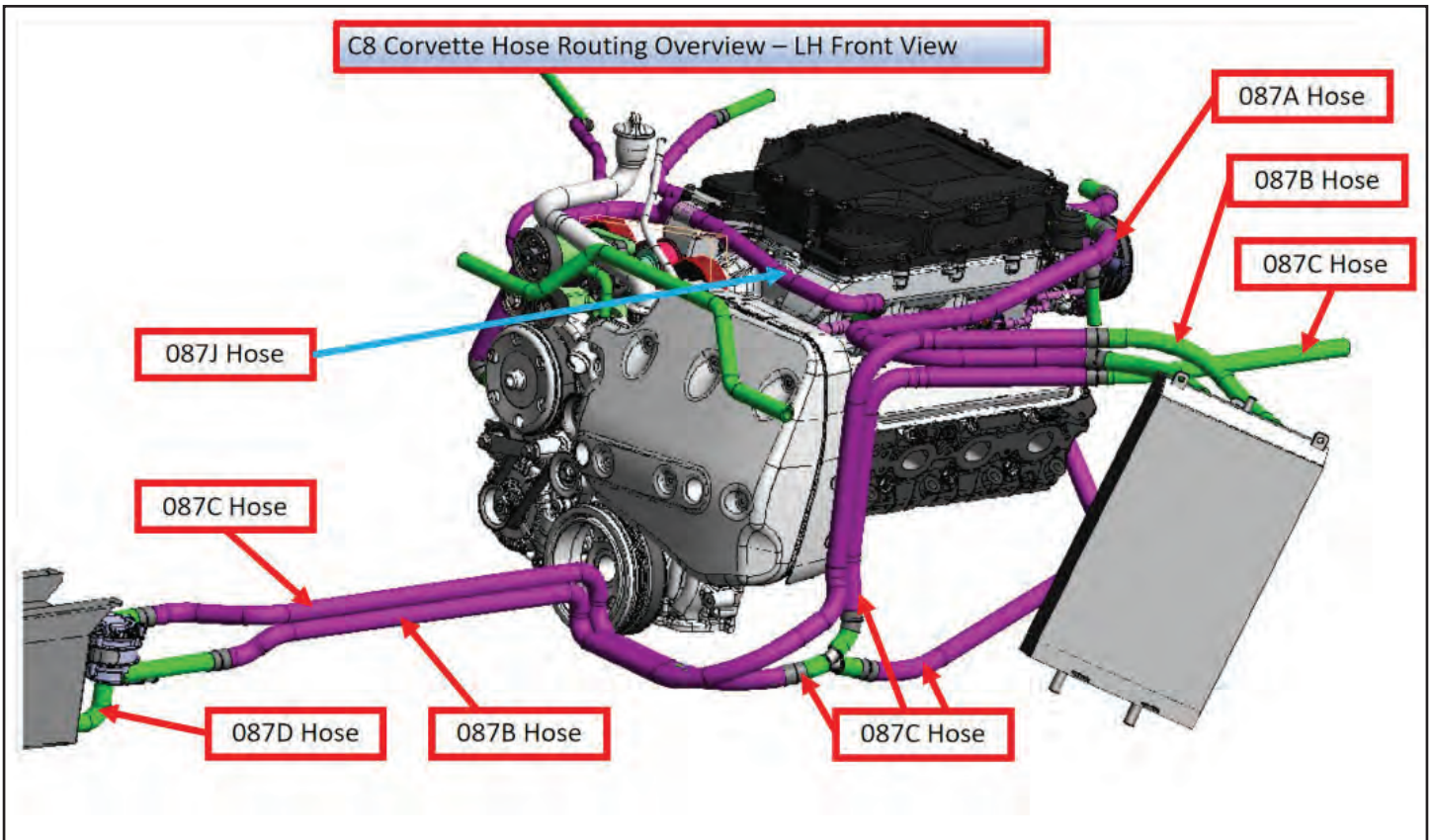
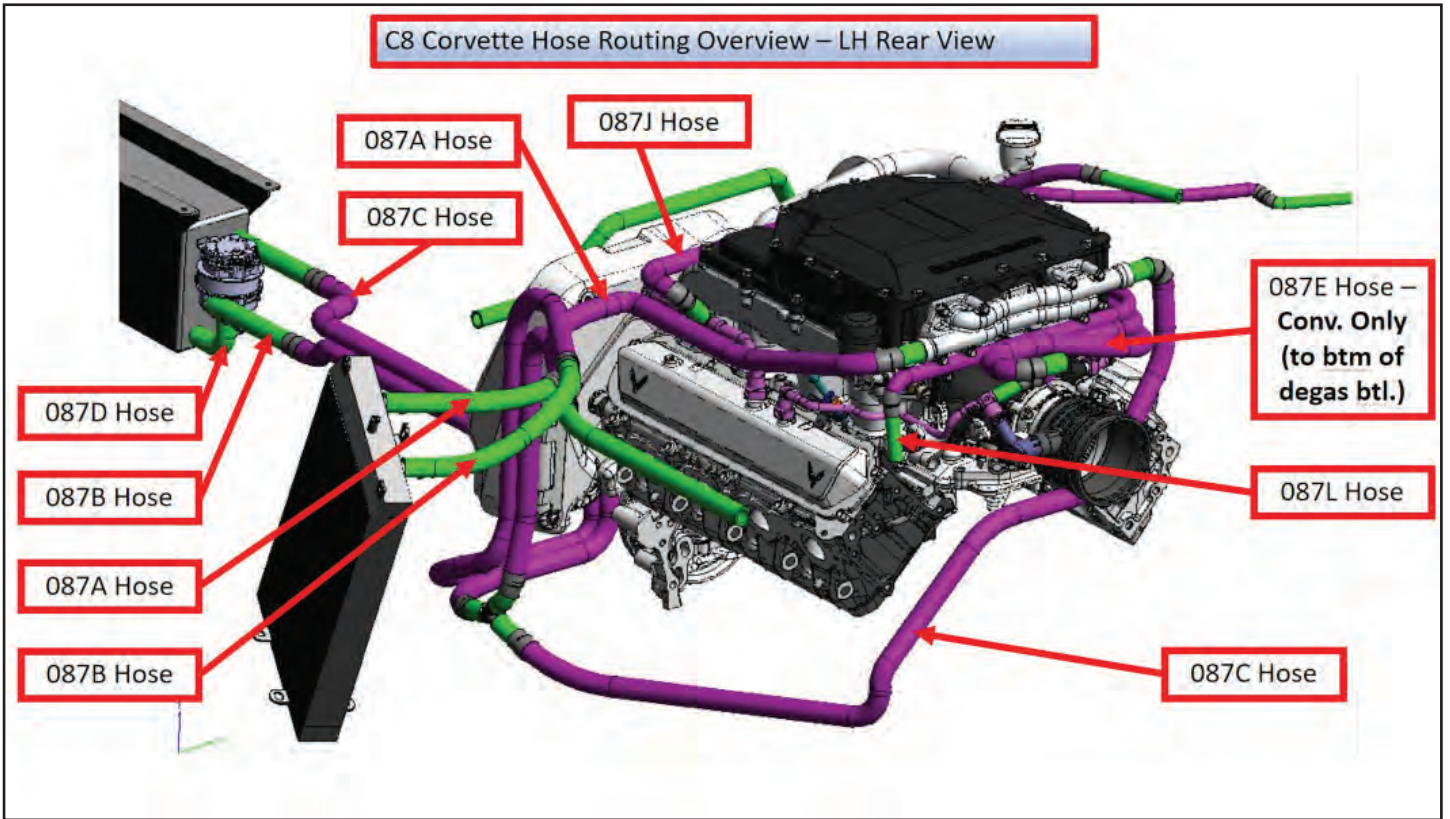

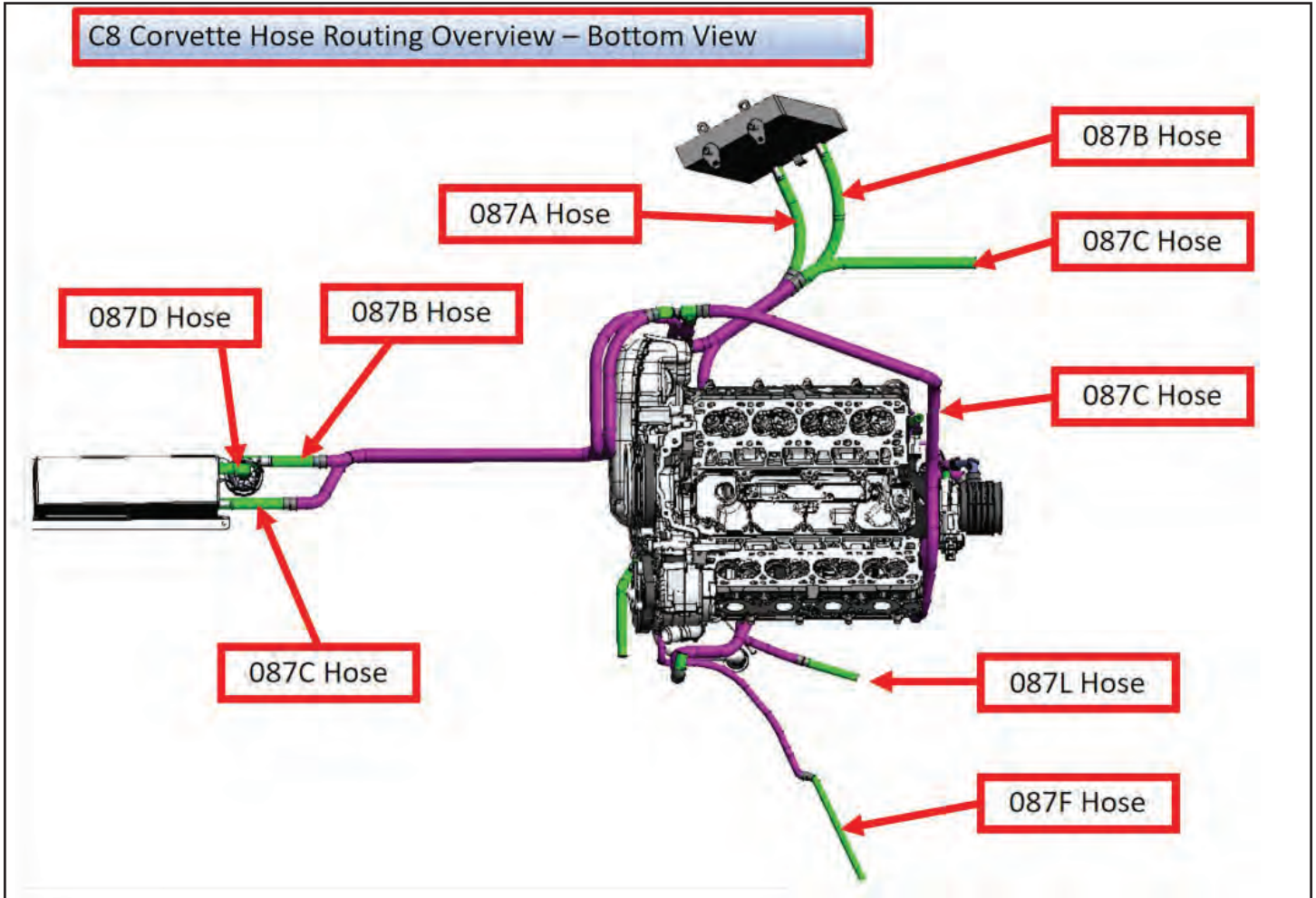



C8 Corvette Hose Routing Overview – Reservoir and Tank Hose Routing

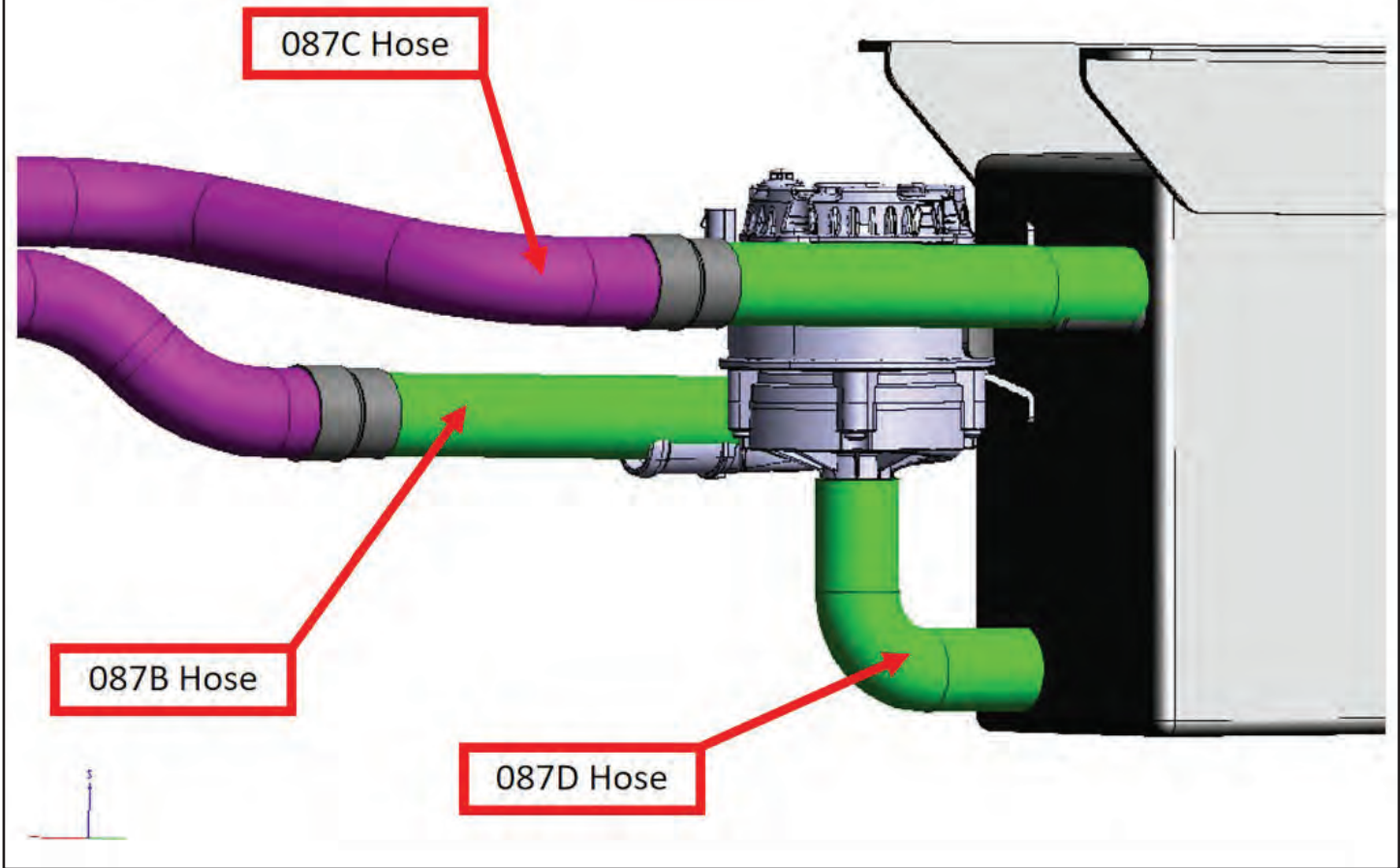

C8 Corvette Hose Routing Overview – Top View

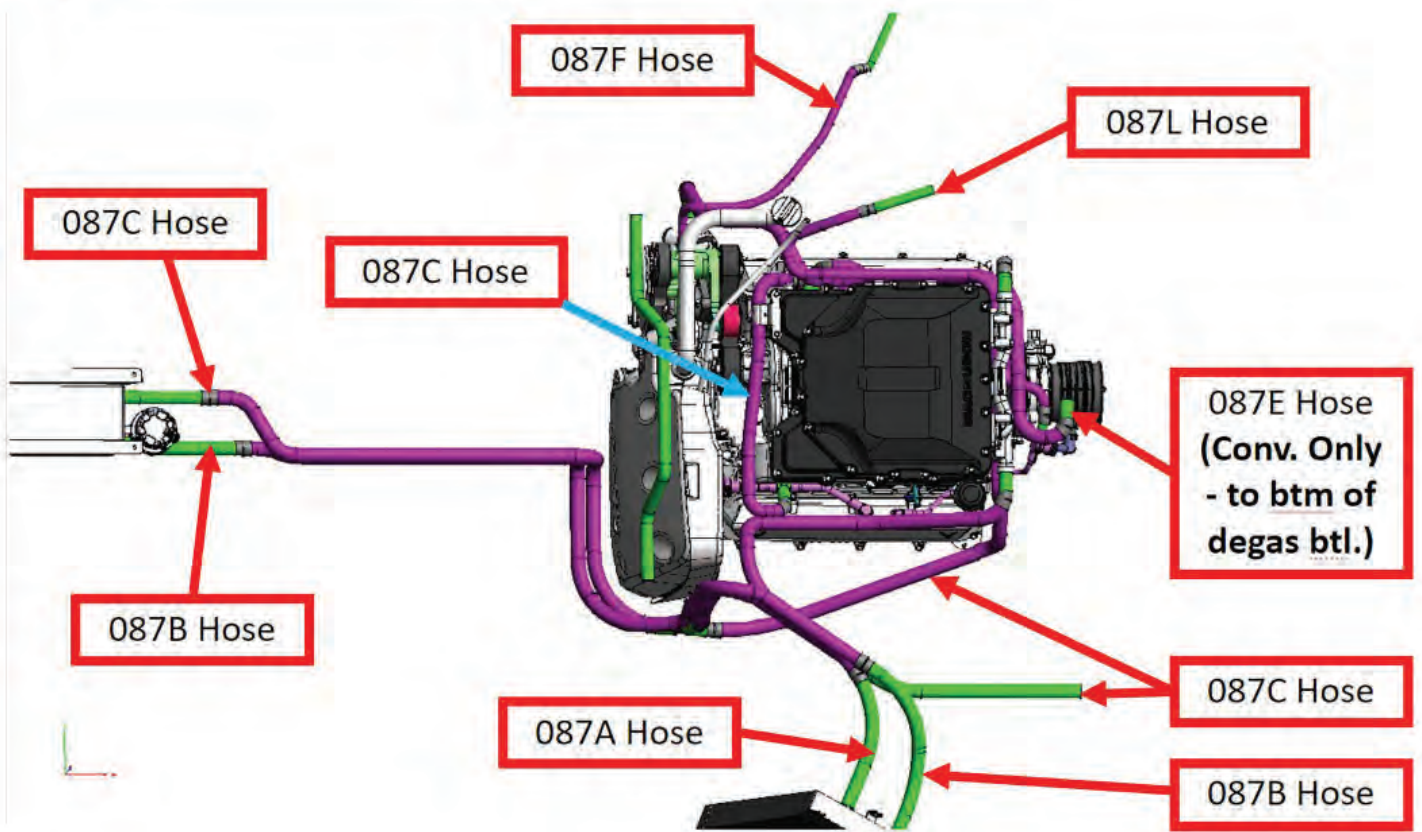



## Appendix C: ECM Removal

**IMPORTANT:** Disconnect the battery before proceeding! See step 18.

Depending on the model year of the vehicle you are working on, the ECM will either be located in the center tunnel area, or behind the LH rear wheel. Locate the ECM and prepare to remove it from the vehicle.

Disconnect (4) electrical connectors @ ECM in vehicle tunnel.

Push tabs down at bottom of ECM bracket then remove the ECM from the bracket.

Carefully package the ECM and send it out to be unlocked as per the instructions on the HP Tuners website.

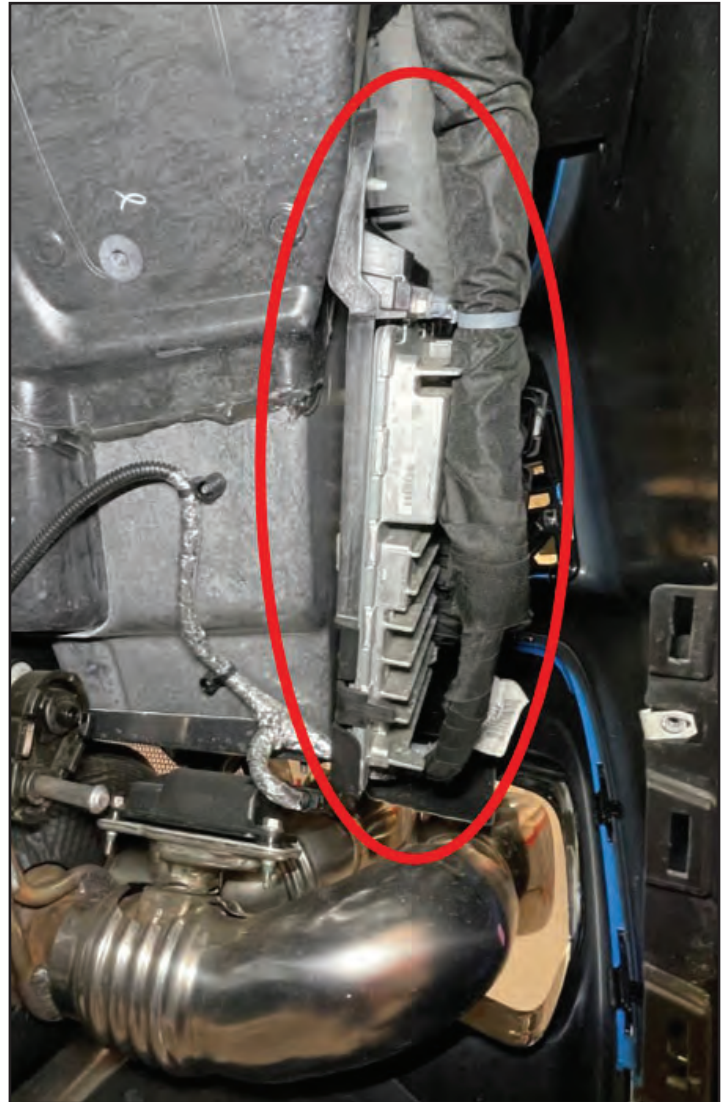

## Appendix D: Fastener Torque Specifications

### **Frunk:**

Battery Post clamp nuts: 4.5 Nm (40 lb in)

### **Exhaust System**

Exhaust Manifold bolts: 20 lb. ft, loosen 180 degrees, then re-torque 17 lb. ft.

Catalytic convertor nuts: 58 Nm (43 lb ft)

Exhaust System Rear nuts: 22 Nm (16 lb ft)

Muffler Hanger Bracket bolts: 22 Nm (16 lb ft)

Exhaust Manifold Heat Shield bolts: 10 Nm (89 lb in)

HEGO Sensors: 42 Nm (31 lb ft)

### **Intake**

Intake Air Duct Bolt: 9 Nm (80 lb in)

Air Cleaner Bolt: 9 Nm (80 lb in)

Air Cleaner Outlet Duct Clamp: 3.5 Nm (31 lb in)

Evap Canister Purge Solenoid Valve bolt: 10 Nm (89 lb in)

### **Underhood**

Upper Frame Cross Brace bolts (under hood): 23 Nm (17 lb ft)

### **Powertrain / Underbody**

Rear Body Compartment Bolts: 2.5 Nm (22 lb in)

Rear Wheel Protective Bumper bolts (Crash bars): 9 Nm (80 lb in)

Upper Control Arm bolts: 58 Nm (43 lb ft)

Rear Suspension Cradle Bolts: 160 Nm (118 lb ft)

Brake Hose Bracket bolts: 9 Nm (80 lb in)

Rear Cradle Brace bolts: First pass 58 Nm. Second pass: rotate clockwise additional 90 – 105 degrees

Fuel Tank Crossover Pipe bolts: 9 Nm (80 lb in)

Fuel Feed Front Hose Clip bolt: 9 Nm (80 lb in)

A/C Line nuts: 22 Nm (16 lb ft)

Radiator Inlet Hose clamp: 5 Nm (44 lb in)

Alternator B+ cable nuts: 15 Nm (11 lb ft)

Trans Control Module bolts: 2.5 Nm (22 lb in)

Fuel Pipe Shield bolts: 9 Nm (80 lb in)

Underbody Rear Air Deflector bolts (M6): 9 Nm (80 lb in) (M8): 22 Nm (16 lb ft)

Tunnel Panel Reinforcement Plate: 22 Nm (16 lb ft)

Tunnel Plate to Rear Cradle Brace bolts: 160 Nm (118 lb ft)

Rear Wheelhouse Liner/Air Deflector/Bumper Fascia bolts and screws: 2.5 Nm (22 lb in)



## Fastener Torque Requirements (cont'd):

Rear Cradle Shear Plate bolts: M8 6-Lobe: 29 Nm (21 lb in). M8 regular bolts: 22 Nm (16 lb ft)

Rear Wheel Driveshafts bolts: First Pass 50 Nm criss-cross pattern. Second Pass Rotate clockwise 40-50 degrees

Rear Wheel Driveshaft Shield bolts: 9 Nm (80 lb in)

Strut Top Mount nuts: (22 lb ft)

Oil Filler Tube bolt: 10 Nm (89 lb in)

Oil Drain plug: 25 Nm (18 lb ft)

Oil Capacity: 7.5 quarts (with filter)

# Appendix E: Belt Routing Diagram for Provided K060722 Belt

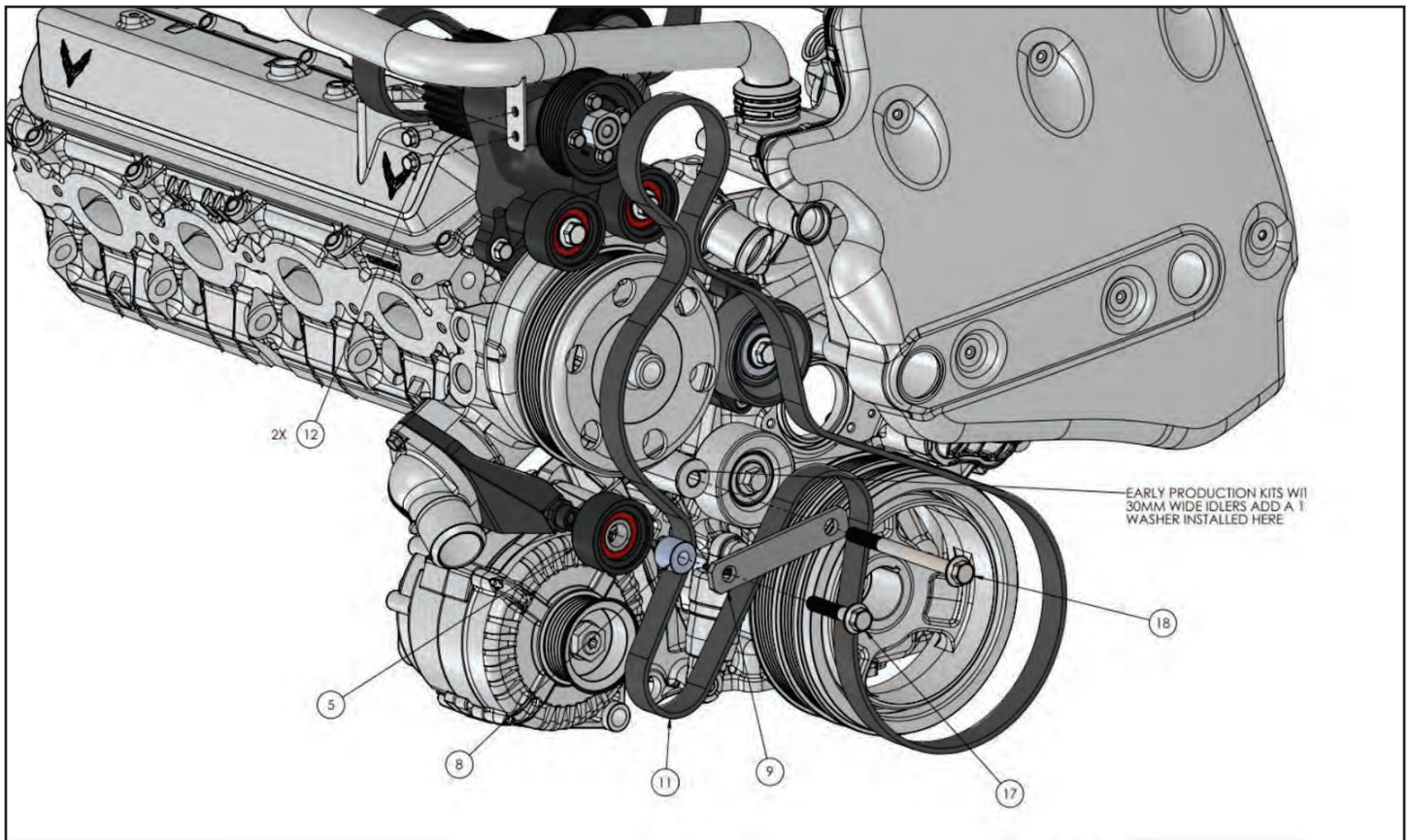



# Appendix F: Belt Routing Diagram for Optional K060710 Belt

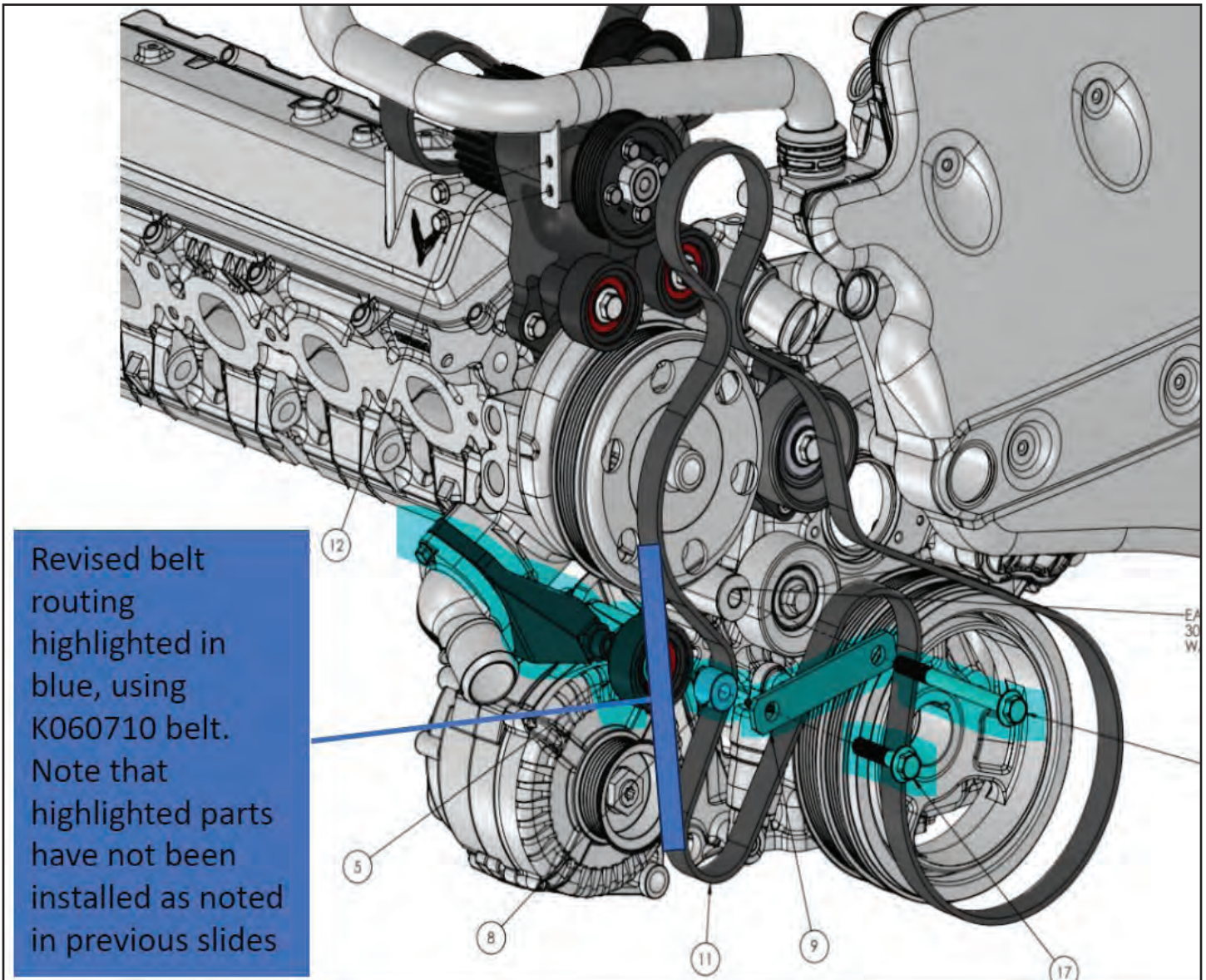

# Appendix G: Fill Reservoir Template

**SHEET SCALE 1 : 1**  
**PRINT PDF ON 8.5 X 11 LANDSCAPE**  
**DO NOT SCALE OR FIT TO PAPER**  
**CHECK DIMENSIONS AFTER PRINTING**

THE INFORMATION CONTAINED IN THIS DRAWING IS THE SOLE PROPERTY OF MAGNUSON PRODUCTS. ANY REPRODUCTION IN PART OR WHOLE WITHOUT THE WRITTEN PERMISSION OF MAGNUSON PRODUCTS IS PROHIBITED.

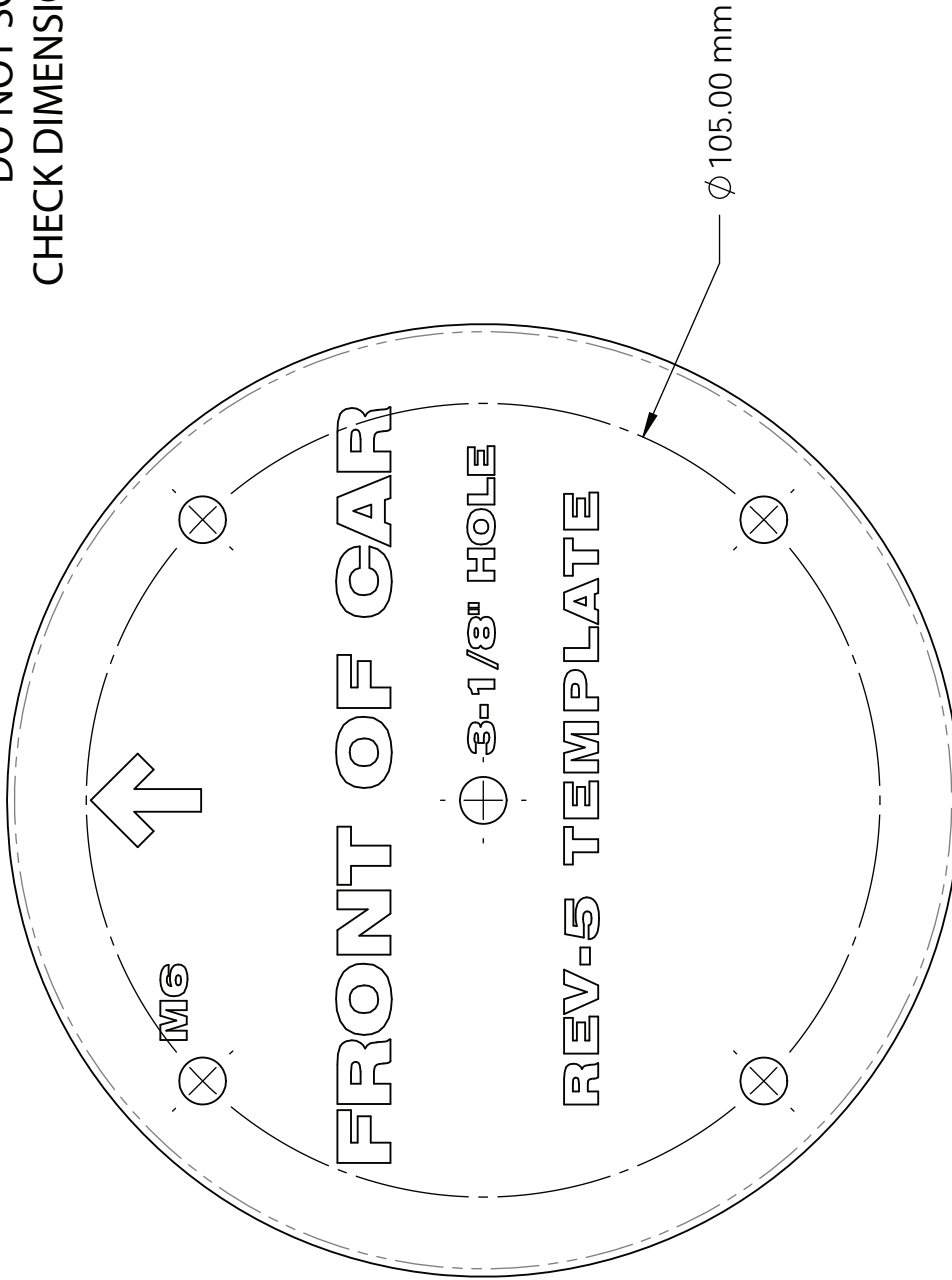

|  |                      |      |
|--|----------------------|------|
| UNLESS OTHERWISE SPECIFIED DIMENSIONS ARE IN MILLIMETERS TOLERANCES ARE: | APPROVALS            | DATE |
|  | DRAWN                |      |
|  | CHECKED              |      |
|  | RESP ENG             |      |
|  | MFG ENG              |      |
| MATERIAL   |                      |      |
| FINISH   |                      |      |
| APPLICATION  | DO NOT SCALE DRAWING |      |

MAGNUSON PRODUCTS  
 1990 KNOLL DRIVE  
 VENTURA, CA 93003  
 (805) 642-8833

**FILL RESERVOIR TEMPLATE**  
**REV-5 BOTTLE ONLY**

|            |             |              |
|------------|-------------|--------------|
| SIZE       | DWG. NO.    | REV.         |
| A          |             |              |
| SCALE: 1/1 | PRINT DATE: | SHEET 1 OF 1 |
|            | 2/14/2023   |              |





Please enjoy your "Magnuson SuperCharged" performance responsibly.

**\* PREMIUM 91 OCTANE GASOLINE FUEL REQUIRED \***

**MAGNUSON**  
*SUPERCHARGERS*