

Standard Features

- Optional pulley's available at time of purchase including GripTec variants and overdrive balancers.
- Supercharger manifold incorporates independent drive and throttle body housings allowing flexible throttle body applications without the need to replace the drive assembly. The supercharger is supplied with an adaptor that accepts standard LSA ETC and 102/103 with use of spacer 99-SPC15300
- Harrop currently stocks natural finish and black 103 throttle bodies, part numbers below:
 - 65-GMTBLS3 GM DBW LS3 Throttle Bdy103MM - Natural
 - 65-GMTBLS3B GM DBW LS3 Throttle Bdy103MM - Black
- New range of 8PK pulleys available as per table below to suit standard LSA drive, coming in 2021 Harrop will stock limited quantities of GripTec alternatives.
- Optional Harrop manufactured manifold thermal insulators available at time of purchase.
- The OEM fuel lines, rails and upper manifold will bolt on directly to the new supercharger.
- A relocation bracket is supplied for the by-pass boost control solenoid valve.
- All standard hoses will fit/connect, ie. the valley plate breather to throttle body adaptor, booster etc.
- The design retains the standard LSA type intercooled by-pass system.
- The supercharger manifold is identical in height to the OEM so there should be no foul conditions.

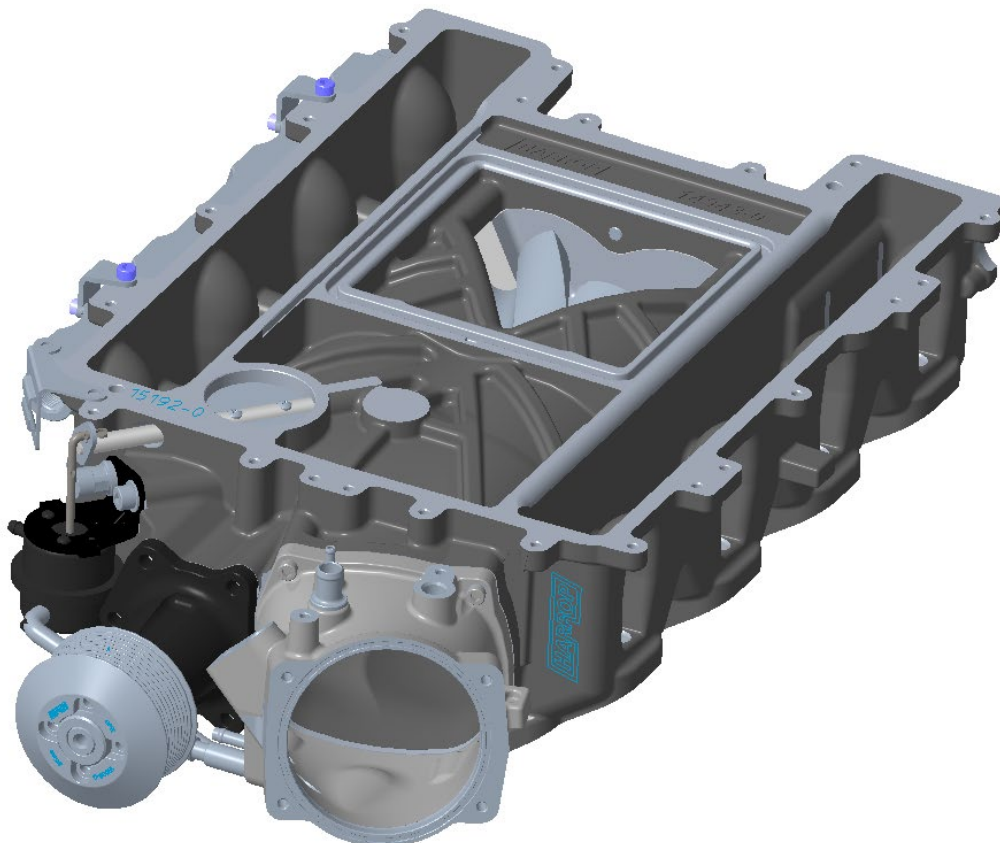

Red highlighted cells indicate high Supercharger speed @ 6600 crank rpm – warranty void

Harrop LSA-H2650i drive pulley matrix

HARROP 2650i LSA DRIVE PULLEY								
DRIVE RATIO	SUPERCHARGER SPEED AT 6600 CRANKSHAFT RPM	SUPERCHARGER PULLEY Ø	SUPERCHARGER PULLEY PART NUMBER	SUPERCHARGER PULLEY DESCRIPTION	CRANK PULLEY Ø	OVERDRIVE CRANK BALANCER	BELT LENGTH	TENSIONER POSITION
3.06	20206	65	99-PLY15004	Pulley S/Chrgr 8PK, 65x30x17.1 Offset, 4x40PCD	199	0%	1650	4
2.84	18763	70	99-PLY15005	Pulley S/Chrgr 8PK, 70x30x17.1 Offset, 4x40PCD	199	0%	1650	4
2.65	17512	75	99-PLY15006	Pulley S/Chrgr 8PK, 75x30x17.1 Offset, 4x40PCD	199	0%	1660	4
2.49	16418	80	99-PLY15007	Pulley S/Chrgr 8PK, 80x30x17.1 Offset, 4x40PCD	199	0%	1660	4
2.34	15452	85	99-PLY15008	Pulley S/Chrgr 8PK, 85x30x17.1 Offset, 4x40PCD	199	0%	1680	4
2.21	14593	90	99-PLY15009	Pulley S/Chrgr 8PK, 90x30x17.1 Offset, 4x40PCD	199	0%	1680	4
3.21	21216	65	99-PLY15004	Pulley S/Chrgr 8PK, 65x30x17.1 Offset, 4x40PCD	209	5%	1660	4
2.99	19701	70	99-PLY15005	Pulley S/Chrgr 8PK, 70x30x17.1 Offset, 4x40PCD	209	5%	1660	4
2.79	18388	75	99-PLY15006	Pulley S/Chrgr 8PK, 75x30x17.1 Offset, 4x40PCD	209	5%	1680	4
2.61	17238	80	99-PLY15007	Pulley S/Chrgr 8PK, 80x30x17.1 Offset, 4x40PCD	209	5%	1700	4
2.46	16224	85	99-PLY15008	Pulley S/Chrgr 8PK, 85x30x17.1 Offset, 4x40PCD	209	5%	1700	4
2.32	15323	90	99-PLY15009	Pulley S/Chrgr 8PK, 90x30x17.1 Offset, 4x40PCD	209	5%	1700	4
3.37	22227	65	99-PLY15004	Pulley S/Chrgr 8PK, 65x30x17.1 Offset, 4x40PCD	219	10%	1700	4
3.13	20639	70	99-PLY15005	Pulley S/Chrgr 8PK, 70x30x17.1 Offset, 4x40PCD	219	10%	1700	4
2.92	19263	75	99-PLY15006	Pulley S/Chrgr 8PK, 75x30x17.1 Offset, 4x40PCD	219	10%	1700	4
2.74	18059	80	99-PLY15007	Pulley S/Chrgr 8PK, 80x30x17.1 Offset, 4x40PCD	219	10%	1725	4
2.58	16997	85	99-PLY15008	Pulley S/Chrgr 8PK, 85x30x17.1 Offset, 4x40PCD	219	10%	1735	4
2.43	16053	90	99-PLY15009	Pulley S/Chrgr 8PK, 90x30x17.1 Offset, 4x40PCD	219	10%	1735	4
3.61	23843	65	99-PLY15004	Pulley S/Chrgr 8PK, 65x30x17.1 Offset, 4x40PCD	234	18%	1725	4
3.35	22140	70	99-PLY15005	Pulley S/Chrgr 8PK, 70x30x17.1 Offset, 4x40PCD	234	18%	1740	4
3.13	20664	75	99-PLY15006	Pulley S/Chrgr 8PK, 75x30x17.1 Offset, 4x40PCD	234	18%	1740	4
2.94	19373	80	99-PLY15007	Pulley S/Chrgr 8PK, 80x30x17.1 Offset, 4x40PCD	234	18%	1755	4
2.76	18233	85	99-PLY15008	Pulley S/Chrgr 8PK, 85x30x17.1 Offset, 4x40PCD	234	18%	1755	4
2.61	17220	90	99-PLY15009	Pulley S/Chrgr 8PK, 90x30x17.1 Offset, 4x40PCD	234	18%	1780	4

Specifying pulley's

If you would like to use the GripTec equivalent then the pulley part number should be expressed as the following:

- Standard Harrop pulley, **99-PLY15008**
- GripTec equivalent pulley, **99-PLY15008-GT**