



AEROMOTIVE
Part # 19101, 19102, and 19103
Phantom Fuel Pump / Baffle System
For 1999-2002 Camaro/Firebird Drop In Modules
INSTALLATION INSTRUCTIONS

Patent 8,783,287

WARNING!



Always be aware of flammable situations. Drilling and grinding can be potential ignition sources. Extinguish all open flames, prohibit smoking and eliminate all sources of ignition in the area of the vehicle and workspace before proceeding with the installation. Ensure you are working in a well-ventilated area with an approved fire extinguisher nearby.

WARNING!



Installation of this product requires modification to a fuel tank, failure to satisfy all safety considerations will result in fire, explosion, injury and/or loss of life to yourself and/or others.

WARNING!



Mechanical and hydraulic lifting devices can tip over or lower accidentally due to incorrect maneuvering or technical errors. A falling object can cause injury and/or loss of life to yourself and/or others. When working under the vehicle always use stands and ensure that the ground or floor is stable and level. Never crawl under a vehicle which is only supported by a jack.

WARNING!



The fuel system is under pressure. Do not open the fuel system until the pressure has been relieved. Refer to the appropriate vehicle service manual for the procedure and precautions for relieving the fuel system pressure.

CAUTION!



When installing this product always wear safety glasses and other appropriate safety apparel. A drilling operation will cause flying metal chips. Flying metal chips can cause eye injury.

CAUTION:



Installation of this product requires detailed knowledge of automotive systems and repair procedures. We recommend that this installation be carried out by a qualified automotive technician. Careless installation of this product can result in damage to the product, injury or loss of life to yourself and/or others.

Parts Included:

1ea Fuel Pump (11140)
1ea Fuel Pump Strainer
1ea Fuel Pump Hanger Assembly
1ea Fuel Pump Foam Baffle Assembly
2ea AN-6 ORB Port Plugs
2ea Male Blade Connector (22-18 GA Red)

2ea Ring Terminal (10-12 GA Yellow for Pump)
2ea Ring Terminal (22-16 GA Red for Level Sensor)
4ea Ring Terminal Cap
2ea 10-24 Nyloc Nuts

Tools Needed:

Wire Cutters
Wire Strippers/Crimpers
Small 3/8" Wrench

Lock Ring Remover Tool

Parts Required: (Not Included)

1 – OEM Replacement Fuel Pump Gasket
PN: GM – 25167743 or Equivalent

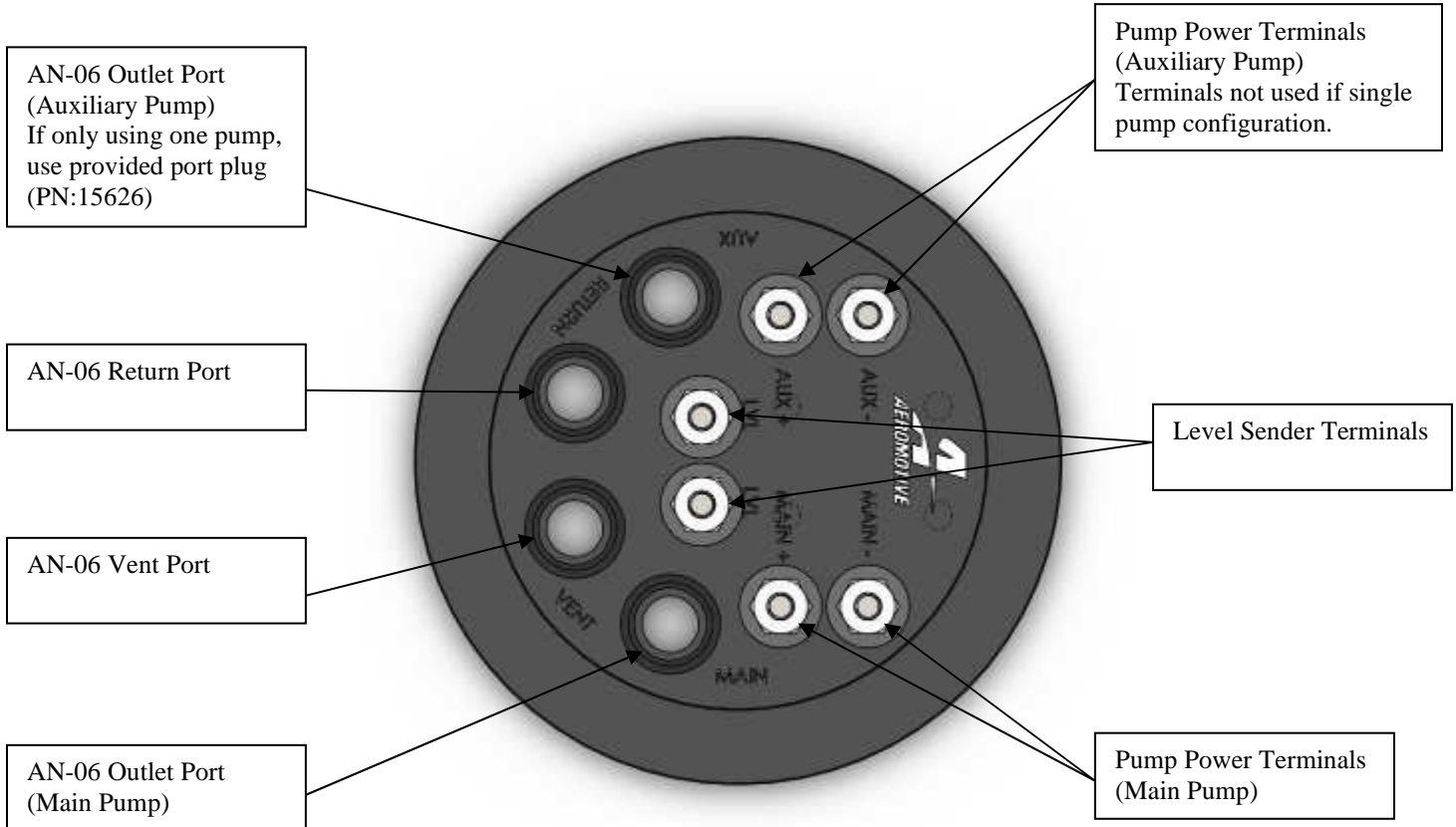

The enclosed Aeromotive fuel pump assembly utilizes an o-ring sealed AN-06 style feed, return and vent ports. These ports seal with o-rings; these ports are **NOT PIPE THREAD** and utilize **NO THREAD SEALANT**.

The fuel pump used in this tank is the Aeromotive Stealth 340 (part # 11140). To ensure proper pump function and life, we strongly recommend the following:

- Utilize AN-06 or AN-08 (EFI) or AN-08 (carb) size high pressure fuel lines, fittings and o-rings for all connections from the fuel tank to the engine, including the supply and return lines.
- Install a 10 micron post-filter (Aeromotive p/n 12301 or 12345).
- Install a remote-mount rollover valve. It must be mounted in a vertical position and mounted as high or higher than your filler tube.
- Fuel pump wiring should be 10 gauge wire and triggered with a relay rated for a minimum of 30 amps (Aeromotive standard fuel pump wiring kit P/N 16301 or the Deluxe HD wiring kit P/N 16307).
- A return style or bypass regulator must be used (Aeromotive p/n 13105, 13109, 13129, or 13303 for EFI, 13204 for carb).

Failure to follow the above recommendations may result in fuel leakage, bursting of the fuel lines, poor vehicle performance and/or decreased fuel pump life! Improper installation will void all warranties for this product!

Pump Specifications:

	19101 Kit (Pump #11140)	19102 Kit (Pump 2x #11140)	19103 Kit (Pump #11145)
Outlet pressure/typical flow:	10 psi / 408 LPH @ 13.5 V 40 psi / 340 LPH @ 13.5 V 60 psi / 284 LPH @ 13.5 V	10 psi / 408 LPH @ 13.5 V 40 psi / 340 LPH @ 13.5 V 60 psi / 284 LPH @ 13.5 V	0 psi / 454 LPH @ 13.5 V 40 psi / 430 LPH @ 13.5 V 60 psi / 381 LPH @ 13.5 V
Continuous Operating Range:	5 psi – 65 psi @ 13.5 V	5 psi – 65 psi @ 13.5 V	5 psi – 65 psi @ 13.5 V
Pump internal By-Pass Pressure:	105 psi	105 psi	120 psi
Current Draw:	13 amps @ 40 psi	2x 13 amps @ 40 psi	15.3 amps @ 40 psi

Aeromotive Commonly Used Fittings

- | | |
|---|----------------------|
| 15689 AN-06 ORB to AN-06 AN Flare 90 Degree (Inlet/outlet/vent fitting) | For AN-06 fuel lines |
| 15606 AN-06 ORB to AN-06 Flare (Inlet/outlet/vent fitting) | For AN-06 fuel lines |
| 15649 AN-06 ORB to AN-08 Flare (Inlet/outlet/vent fitting) | For AN-08 fuel lines |
| 15609 AN-10 ORB to AN-06 Flare (fuel filter fitting) | For AN-06 fuel lines |
| 15610 AN-10 ORB to AN-08 Flare (fuel filter fitting) | For AN-08 fuel lines |

Aeromotive AN-10 Fuel Filter P/N's

- | | |
|------------------------------------|---|
| 12301 Red 10-micron Fuel Filter | 12304 Red 100-micron Fuel Filter |
| 12321 Black 10-micron Fuel Filter | 12324 Black 100-Micron Fuel Filter |
| 12351 Chrome 10-micron Fuel Filter | 12354 Chrome-100 micron Fuel Filter |
| 12335 Red 40-micron Fuel Filter | 12331 Black-100 micron Fuel Filter w/ Shutoff Valve |
| 12305 Fuel Filter Bracket | |

Aeromotive Electrical Components

- 16301 Standard Fuel Pump Wiring Kit
- 16307 Deluxe HD Fuel Pump Wiring Kit
- 16306 Fuel Pump Speed Controller

Aeromotive system components are not legal for sale or use on emission-controlled motor vehicles.

CAUTION:



Aeromotive Phantom Components, including the Phantom 340 Stealth Pump and the patented Foam and Bladder Baffle assembly, have been thoroughly tested for use in common pump gas, non-oxygenated racing gas, ethanol including E85 from corn, and petroleum based (not-bio) diesel fuel. Blending fuels and/or additives, including cleaners, stabilizers or octane boosters, cannot be tested and could result in damage to Phantom system components or other components in the fuel system. These failures cannot be anticipated and may not be covered under warranty. Contact the Aeromotive Tech Department with any questions on blending of fuels and/or use of additives.



This Aeromotive Phantom Fuel Pump System is intended to be installed into a **NEW** fuel tank that does **NOT**, and has **NEVER** contained fuel. If you choose to install this product into a fuel tank that has had fuel introduced to it, proceed at your own risk.



The fuel tank must be professionally cleaned to remove all traces of any combustible fluids. Failure to properly clean and remove all combustible fluids from the fuel tank will result in injury or loss of life to yourself and/or others.

Note: This fuel system is designed for Chevrolet Camaro/Pontiac Firebird model years 1999-2002 with plastic fuel tanks only. Vehicles in the model year 1998 used a steel fuel tank, this system is not compatible with a steel fuel tank.

The following steps are typical of most installations:

1. Once the engine has been allowed to cool, disconnect the negative battery cable and relieve the fuel system pressure, referring to the appropriate vehicle service manual for the procedure and precautions for doing so.
2. Raise the vehicle on stable level ground and support it with jack stands.
3. Referring to the appropriate vehicle service manual for instructions, drain, disconnect any electrical and fuel system component connections and remove the OEM fuel tank. The removal of the vehicles exhaust system may be necessary for fuel tank removal.
4. With the new cleaned fuel tank on your preferred work surface, ensure you have all components listed above to complete the installation.
5. Using the lock ring removal tool, remove the OEM lock ring and carefully remove the OEM fuel pump assembly. Be careful to not damage the fuel level sender during the removal process as this can be reused later during assembly.



OEM Fuel Level Sender

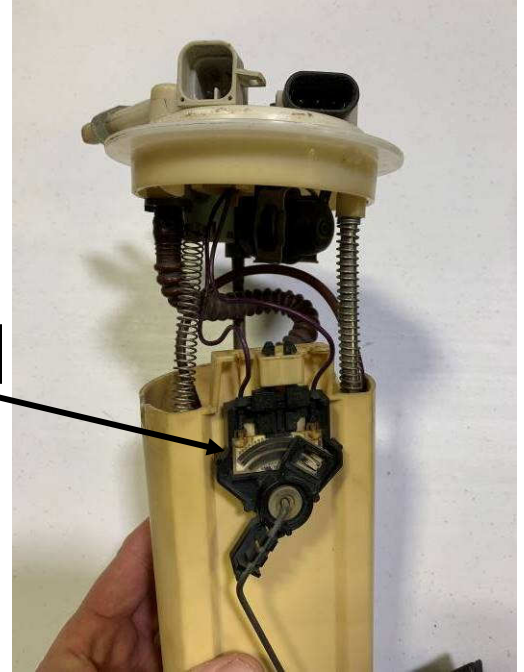

6. Remove the OEM fuel level sender from the OEM pump assembly. To do this, first unplug the connector from the bottom of the fuel pump outlet cap that has the two wires from the fuel level sender connected to it. Next, remove the small retainer clip from the fuel level sender, then press the two small tabs together while carefully pushing down on the level sender to remove it from the OEM pump assembly.
7. Cut the two wires from the fuel level sender loose from the plug, leave as much wire as possible. Then, strip the two wires and crimp on the two provided male spade terminals.

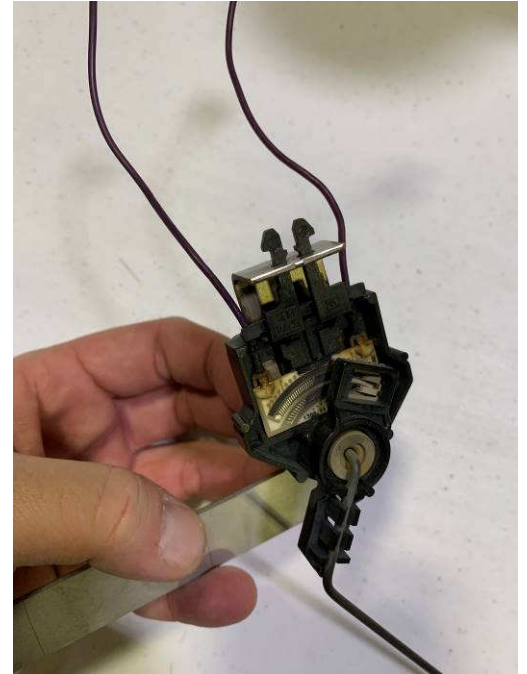
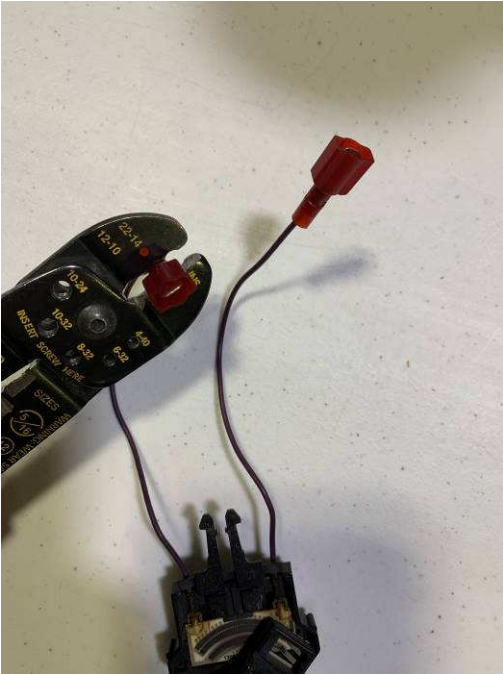

8. Next, install the fuel level sender on the provided fuel level sender bracket. To do this, slide the level sender upwards on the bracket while pressing the two tabs together and insert them through the slot on the top of the bracket. See the picture above for the proper fuel level sender orientation on the bracket.

9. Install the foam and basket assembly into the tank. To do this, first ensure the foam is pushed all the way into the black fuel basket before inserting into the tank. Next, roll the foam and basket and carefully insert into the tank, ensure the basket does not separate from the foam. Once in the tank, position the foam so it is concentric with the fuel pump hole in the tank. The window in the tank should be facing the passenger side of the tank. **Note: The orientation of the window in the foam is important as this is where the fuel level sender will pass through.** See pictures below.

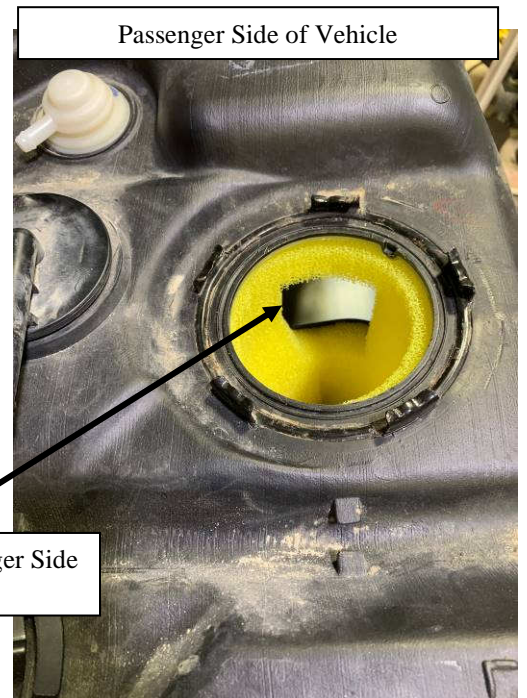

Position Window in Foam to Face Passenger Side of the Vehicle.

10. Next, loosely insert the fuel level sender bracket/fuel level sender through the window in the foam. Be careful not to bend or damage the fuel level sender while inserting it in the tank. Make sure to leave the sending unit wires sticking out of the hole to connect them to the wires attached to the outlet cap. See pictures below.



11. Once the fuel level sender bracket assembly has been loosely installed in the tank, install a new fuel pump assembly gasket (not included).



12. Connect the two white wires from the outlet cap (LVL and LVL) to the two wires from the fuel level sender and loosely insert the fuel pump assembly into the tank. Push the white wire excess through the window in the foam and loosely hang the fuel level sender bracket flange on the edge of the hole as shown in the picture below.

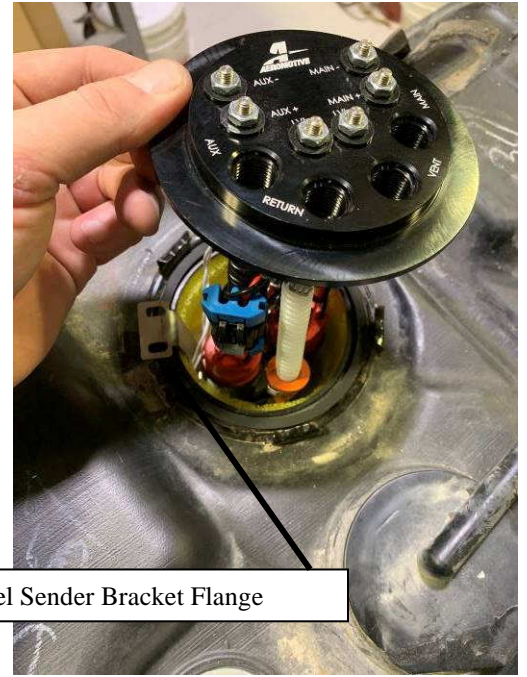
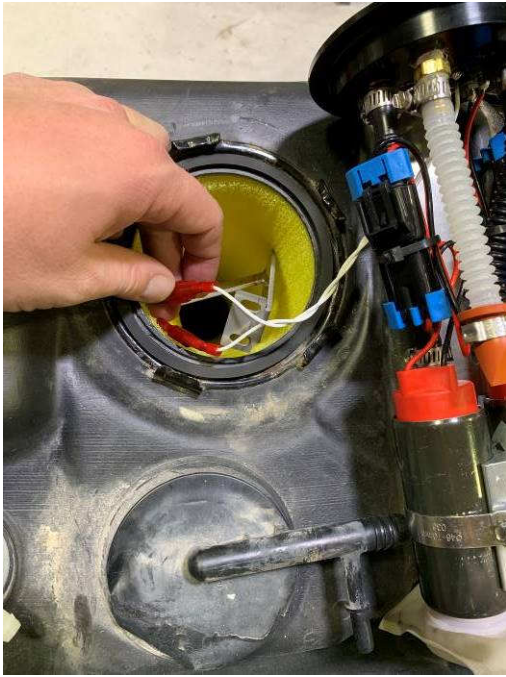

Level Sender Bracket Flange

13. Before fully inserting the pump assembly into the tank you must connect the fuel level sender bracket to the outlet cap. To do this, pull up on the fuel level sender bracket and align the slots with the two 10-24 studs on the underside of the outlet cap. Attach the level sender bracket to the outlet cap using the two provided 10-24 Nyloc nuts. A small 3/8" wrench works well for this step.

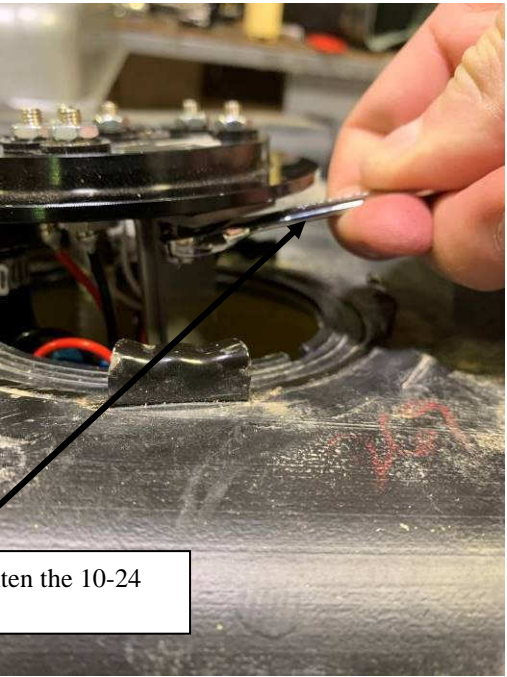
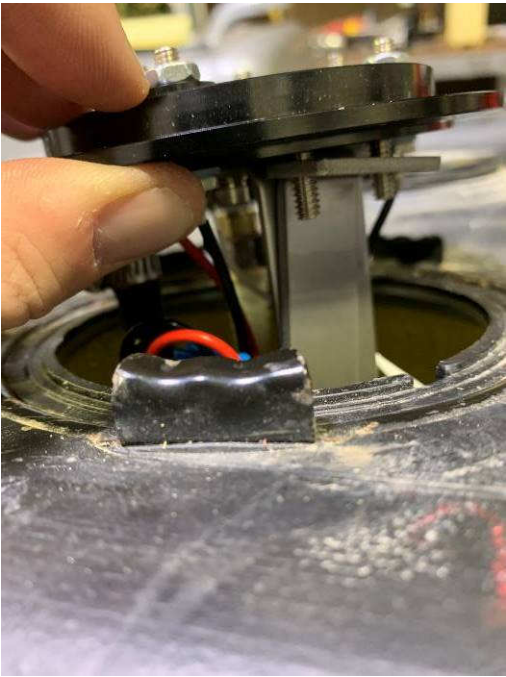

Use Small 3/8" Wrench to Tighten the 10-24 Nyloc Nuts

14. Fully install the pump assembly and fuel level sender into the tank. **Caution: Take special care to ensure that the fuel pump wires, and fuel level sender wires are fully inside the tank and will not be pinched in between the pump assembly outlet cap and the fuel tank.**

15. Rotate the pump assembly outlet cap so the orientation looks like the picture below. **Note: This is very important as the fuel level sender will not read correctly if the cap is not oriented as shown in the picture below.**

Passenger Side of Tank

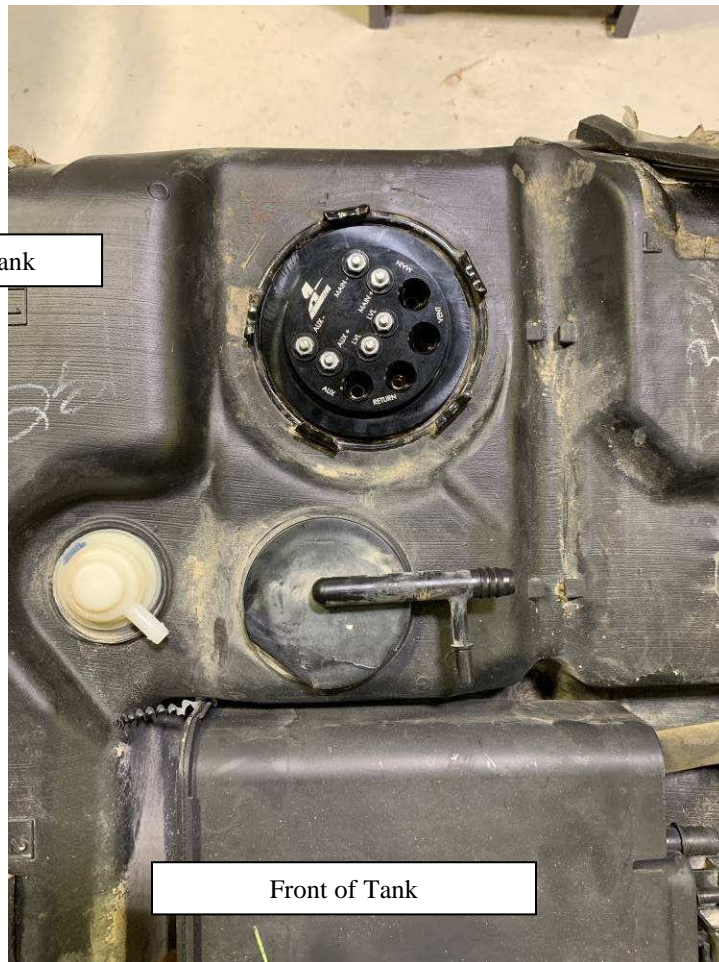

Front of Tank



16. Ensure the gasket is seated in the groove and re-install the OEM fuel pump lock ring and tighten.

17. Prep the new tank by making all the necessary connection (feed, return, vent and electrical) before placing tank in vehicle. In most cases, once the tank is placed in the vehicle these connections will not be accessible. For electrical wiring refer to **Figure 2-1**.
18. Reinstall the fuel tank in the vehicle. In some cases, it may be necessary to space the fuel tank down to allow additional clearance for the new pump outlet. Additional fabrication may be necessary to gain clearance in extreme cases. **Note: Tank vent must be at least 6" above the top of the tank if a roll-over valve is used highly recommended).**
19. Now route the feed and return line under the vehicle and secure them to the chassis. It's recommended to install a post-filter between the fuel pump and the engine (see Aeromotive part # 12345 for single pumps, or part # 12339 for dual pumps). Place the filter in a location that is clear of suspension and exhaust system components and easy to get to for servicing.

Note: Be sure to route all fuel lines clear of any moving suspension or drivetrain components, and any exhaust components! Protect fuel lines from abrasion and road obstructions or debris.



340LPH

FUEL INJECTED - DUAL FUEL RAIL

*flywheel	Naturally Aspirated	Forced Induction
GAS E85	850hp 595hp	700hp 490hp

450LPH

FUEL INJECTED - DUAL FUEL RAIL

*flywheel	Naturally Aspirated	Forced Induction
GAS E85	1,100hp 750hp	800hp 550hp

DUAL 340LPH

FUEL INJECTED - DUAL FUEL RAIL

*flywheel	Naturally Aspirated	Forced Induction
GAS E85	1,700hp 1,190hp	1,400hp 980hp

Note: Above diagram shows typical plumbing of a Single 340, Dual 340, or Single 450 pump Stealth system.

20. Connect electrical power (12 VDC) to the pump(s). Make sure you use stranded, insulated copper wire, in the sizes shown, with matching crimp-type connectors for all connections. **CAUTION: The pump must not be connected directly to the battery.** Note: One 30 AMP relay required per pump. Connect the Aeromotive fuel pump(s) as shown in the following diagram:

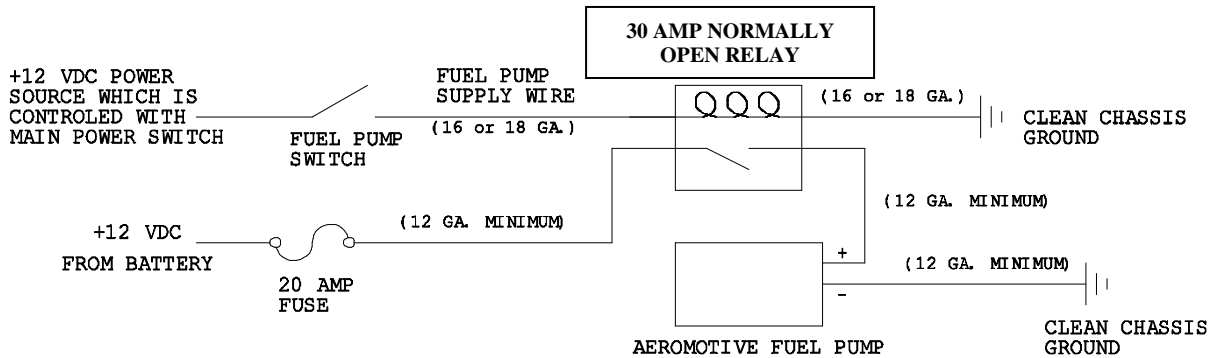

Figure 2-1

CAUTION: While performing the following steps, if any fuel leaks are detected, immediately turn the fuel pump OFF, remove any spilled fuel and repair the leak(s) before proceeding!

21. Turn the fuel pump ON **without starting the engine**, allow the pump to run for several seconds and check the fuel pressure. If there is no pressure, turn the fuel pump OFF, wait one minute, then turn the fuel pump ON and recheck the pressure. Repeat this fuel pump OFF and ON procedure until the fuel pressure gauge registers pressure or you detect a fuel leak. It may be necessary to loosen the fuel line fitting at the pressure regulator to bleed off excessive air in the system. Tighten any fuel line fittings which were loosened and ensure that any spilled fuel is cleaned up and removed from the vicinity of the vehicle. If no pressure is registered on the gauge after running the pump for several seconds and you have found no leaks, check all fuel and electrical connections to determine the cause.
22. Once the fuel pressure gauge registers pressure, start the engine. The gauge on the fuel pressure regulator should register between 3 and 12 psi for carb and 35-60 for EFI. Now adjust the fuel pressure regulator to the desired setting.

Test drive the vehicle to ensure proper operation and re-check the fuel system for leaks. **If any leaks are found, immediately discontinue use of the vehicle and repair the leak(s)!**



WARNING: This product can expose you to chemicals, including chromium, which is known to the State of California to cause cancer or birth defects or other reproductive harm. For more information, visit: www.p65Warnings.ca.gov

AEROMOTIVE, INC. LIMITED WARRANTY

This Aeromotive Product, with proof of purchase dated on or after January 1, 2003, is warranted to be free from defects in materials and workmanship for a period of one year from the original date of purchase. No warranty claim will be valid without authentic, dated proof of purchase.

This warranty is to the original retail purchaser and none other and is available directly from Aeromotive and not through any point of distribution or purchase.

If a defect is suspected, the retail purchaser must contact Aeromotive directly to discuss the problem, possible solutions and obtain a Return Goods Authorization (RGA), if deemed necessary by the company. Please call 913-647-7300 and dial option 3 for the technical service dept. All returns must be shipped freight pre-paid to the company and with valid RGA before they will be processed.

Aeromotive will examine any product returned with the proper authorization to determine if the failure resulted from a defect or from abuse, improper installation, misapplication or alteration. Aeromotive will then, at it's sole discretion, return, repair or replace the product.

If any Aeromotive product is determined defective, buyer's exclusive remedy is limited in value to the sale price of the good. In no event shall Aeromotive be liable for incidental or consequential damages.

Aeromotive expressly retains the right to make changes and improvements in any product it manufactures and sells at any time. These changes and improvements may be made without notice at any time and without any obligation to change the catalogs or printed materials.

Aeromotive expressly retains the right to discontinue at any time and without notice any Aeromotive product that it manufactures or sells.

This warranty is limited and expressly limits any implied warranty to one year from the date of the original retail purchase on all Aeromotive products.

No person, party or corporate entity other than Aeromotive shall have the right to: determine whether or not this Limited Warranty is applicable to any Aeromotive product, authorize any action whatsoever under the terms and conditions of this Limited Warranty, assume any obligation or liability of any nature whatsoever on behalf of Aeromotive under the terms and conditions of this Limited Warranty.

This Limited Warranty covers only the product itself and not the cost of installation or removal.

This Limited Warranty is in lieu of and expressly excludes any and all other warranties, expressed or implied. This Limited Warranty gives you specific legal rights, and you may also have other rights which vary from state to state.