

ATTENTION!

For maximum performance and durability the Camaro Stealth A1000 and Eliminator Fuel Systems must be installed using the appropriate lines, filters, fuel rails, bypass pressure regulator, and electrical system. Failure to use the properly matched components will result in loss of performance and premature failure.

To date the only authorized installation center for this system is IPS Motorsports. Visit IPS at www.ipsmotorsports.com

If you choose not to use IPS please pay close attention to the installation diagrams.

*** A1000 Stealth Pump, use the following:**

- 1 - 18673 A1000 Stealth Fuel Pump
- 1 - 12301 10-m Billet Fuel Filter
- 1 - 12305 Billet Fuel Filter Bracket
- 1 - 14115 LS3 Billet Fuel Rail
- 1 - 13101 A1000 EFI bypass regulator
- 1 - 16306 Fuel Pump Speed Controller or 16301 HD Fuel Pump wiring kit
- 1 - 15674 AN-08 to 2 - AN-08 Y-block
- 7 - 15607 ORB-08 to AN-08 port fitting, two for the top hat and four for the fuel rails.
- 4 - 15610 ORB-10 to AN-08 port fitting, two for the filter and two for the regulator inlets.
- 1 - 15649 ORB-06 to AN-08 port fitting, for the regulator return port.

*** Eliminator Stealth Pump, use the following:**

- 1 - 18674 Eliminator Stealth Fuel Pump
- 1 - 12335 40-m Billet Fuel Filter
- 1 - 14115 LS3 Billet Fuel Rail
- 1 - 13110 Pro-Series EFI Regulator
- 1 - 16306 Fuel Pump Speed Controller
- 1 - 15675 AN-10 to 2 AN-08 Y-block
- 1 - 15641 ORB-08 to AN-10 port fitting (for the fuel pump outlet)
- 1 - 15608 ORB-10 to AN-10 port fitting (you need 2 of these for the 12335 fuel filter, but you'll have 1 unused from the regulator return port, which comes complete with fittings.
- 1 - 15610 ORB-10 to AN-08 (for the regulator return port to AN-08)
- 6 - 15607 ORB-08 to AN-08 port fittings (4 for the fuel rails and one for the return port in the top hat).
- 1 - 12305 Billet fuel filter bracket.

*** Make sure you use proper line sizes identified in the enclosed diagram**



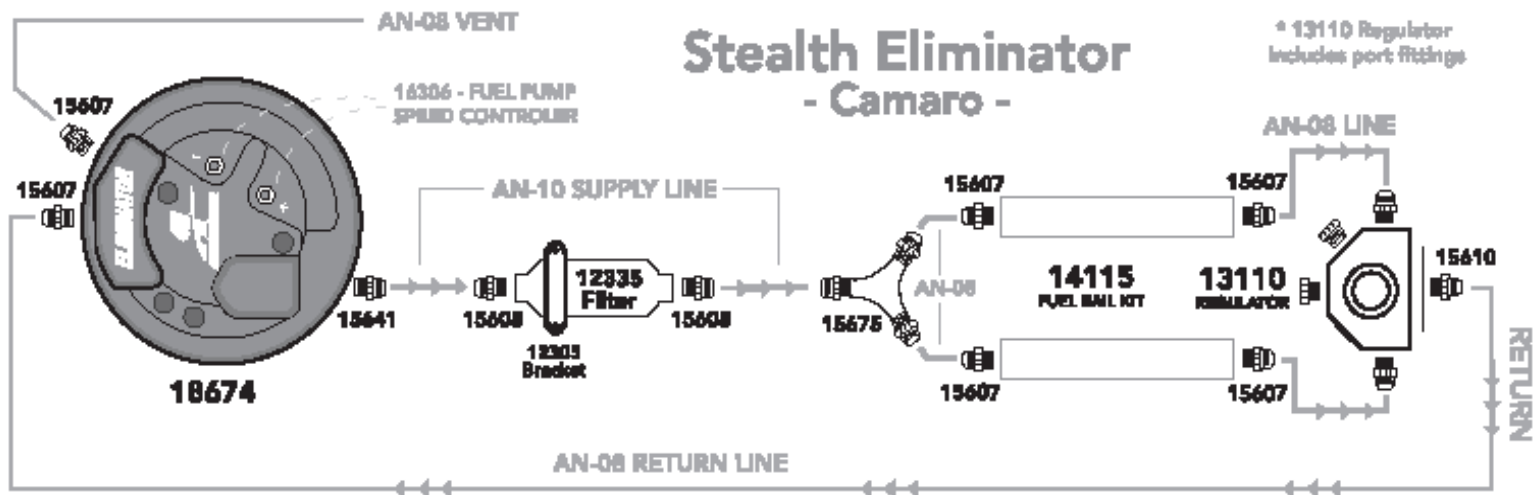
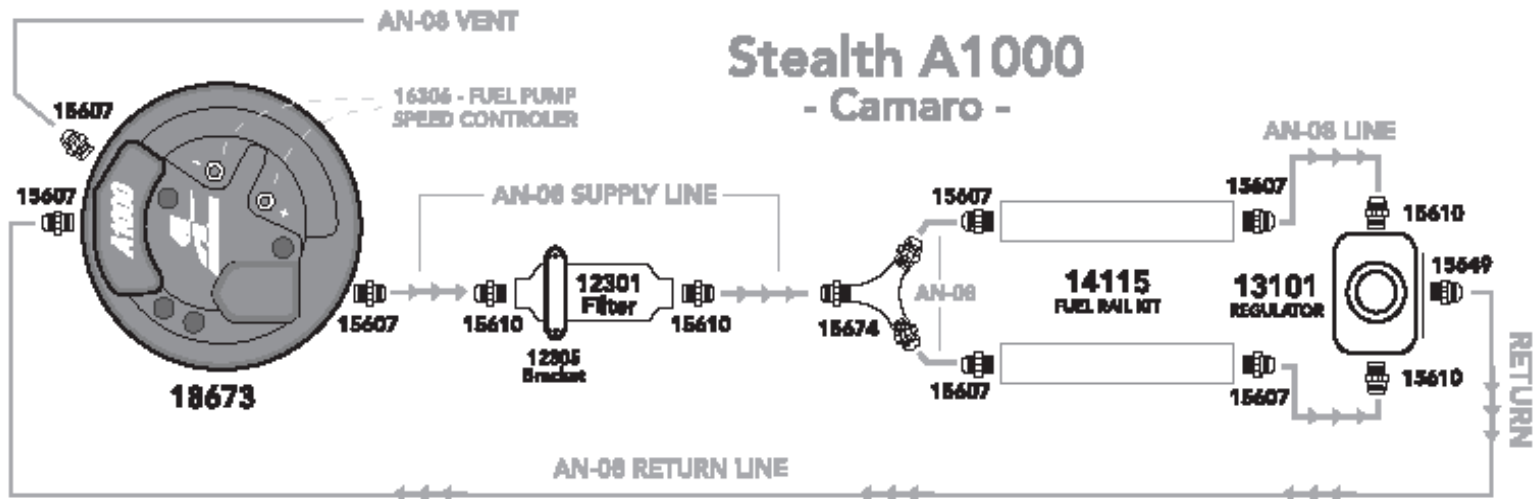



18673, 18674 INSTALLATION INSTRUCTIONS

WARNING!

The fuel system is under pressure. Do not open the fuel system until the pressure has been relieved. Refer to the appropriate vehicle service manual for the procedure and precautions for relieving the fuel system pressure.

This pump assembly is a high performance factory replacement unit. Key features:

- Drops directly into the factory fuel tank (**NO CUTTING REQUIRED**).
- Utilizes the factory jet siphon system so it operates just like GM intended.
- High flow pre-filter built into inlet of pump.
- Includes fuel level mounting bracket for factory leveling unit.

NOTE: The use of Teflon braided line with machine crimped hose ends is recommended. This eliminates the possibility of fuel vapors permeating through the fuel line. The use of a 16306 speed pump controller is also highly recommended, this will keep the fuel cool and reduce noise inside the passenger compartment.

CAUTION:

Installation of this product requires detailed knowledge of automotive systems and repair procedures. We recommend that this installation be carried out by a qualified automotive technician.

Installation of this product requires handling of gasoline. Ensure you are working in a well ventilated area with an approved fire extinguisher nearby. Extinguish all open flames, prohibit smoking and eliminate all sources of ignition in the area of the vehicle before proceeding with the installation.

Maximum continuous operating pressure should not exceed 70 psi.

The enclosed Aeromotive fuel pump utilizes AN-08 ORB (O-ring Boss Ports) style outlet port and AN-08 return port; these ports are **NOT PIPE THREAD** and utilize **NO THREAD SEALANT**.

NOTICE TO INSTALLER:

Installation of this fuel pump requires fuel system conversion to a return style fuel system (use of a bypass style regulator). Also note that a check engine light may be present after installation due to the factory returnless system being modified. This can be turned off with tuning software.

NOTE: Due to tight clearance between the top of the fuel tank and body, Aeromotive includes fuel tank strap spacers and high density foam to space the tank down.

Compatible Fuels:

Pump Gas
Race Gas
E85
Alcohol/Ethanol

Aeromotive Related LS Components:

Fuel Filters:

12301 (pump/race gas) 10 micron
12335 (race gas/E85) 40 micron
12305 (filter bracket)

Fuel Pressure Regulators:

13101 (10AN ports)
13109 (6AN ports)

Electrical Components:

16301 (pump wiring kit)
16306 (pump speed controller)

Check Valves:

15106 (6AN)
15107 (10AN)

Fuel Pressure Gauge:

15633 (dry 0-100psi)

Fuel Rails:

14106 (LS1/LS6)
14114 (LS2)
14115 (LS3/L76)
14142 (LS7)
14147 (LS1, Edelbrock 29085)
14156 (Platinum LS1/LS6)

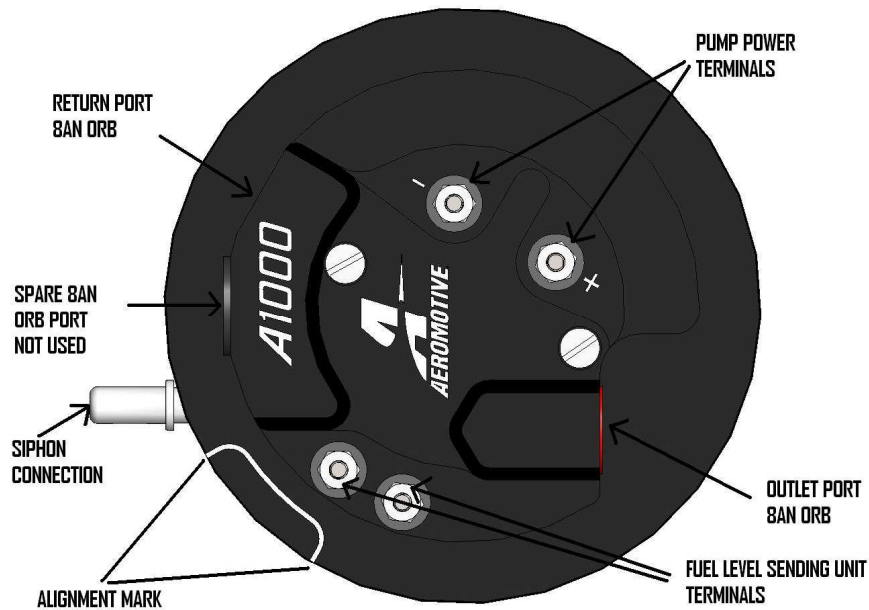

TOP PLATE LAYOUT

The following steps are typical of most installations:

1. Disconnect the negative battery cable and drain the fuel tank.
2. Raise and support the vehicle.
3. Remove the exhaust and rear wheels from vehicle.
4. Remove driveshaft heat shield, drive shaft and fuel tank heat shield.
5. Remove the emergency brake cables from the three way tee and swing them towards the rear of the vehicle.
6. Remove the lower shock bolts.
7. Disconnect rear sub frame wiring located on passenger side frame rail.
8. Disconnect all the following connections in **Figure 1-1**.

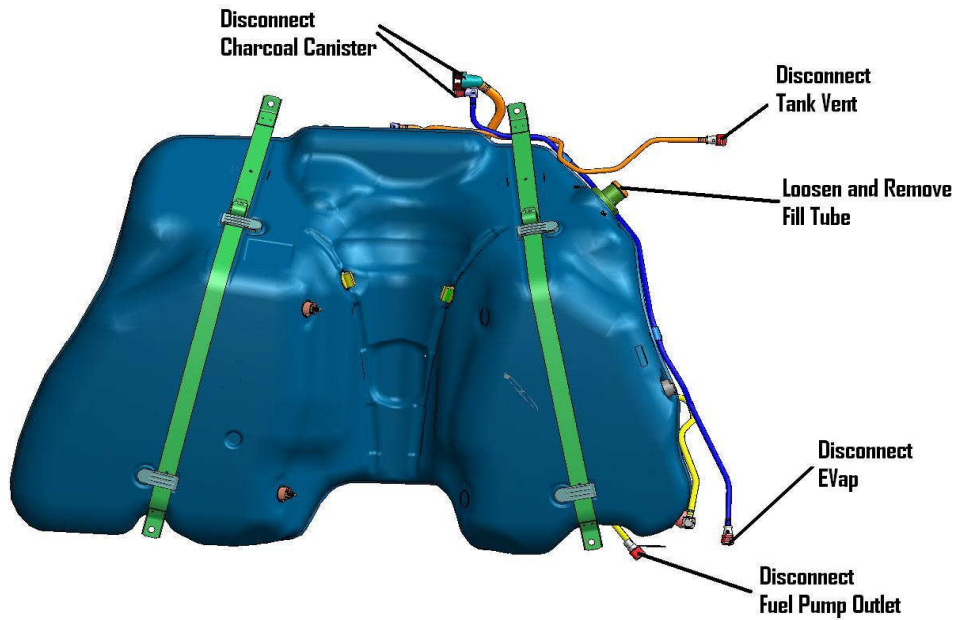

FIGURE 1-1

9. Support the rearend (complete IRS sub frame) with a suitable jack (transmission jack works best). Remove the four 24mm bolts that hold the sub frame in. Carefully lower the rear end, paying close attention to the brake lines on each side of the frame. There is enough length on the brake lines to get the tank out without removing the calipers. Once lowered, support the complete IRS sub frame with jackstands.
10. Remove the evap canister. This is done by unplugging all hoses and wires and removing the two 10mm bolts.
11. Unplug and remove the wiring harness connection at the tank on the passenger side.
12. Remove the fuel tank strap mounting bolts (15mm), tank straps and drop the tank out of the car. **NOTE: It's recommended to do this with two people.**
13. Now remove the pressure feed line and pressure sensor. Also remove the lock ring holding the fuel pump module in place. **NOTE: The fuel pump module is spring loaded and will pop up. FIGURE 1-2**

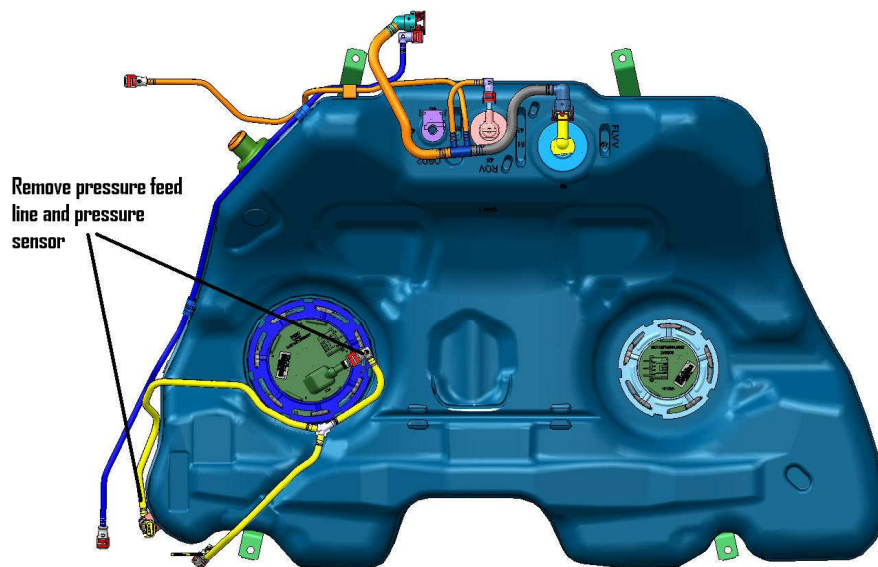

FIGURE 1-2

12. Carefully remove the fuel pump assembly as not to bend the float arm. There will also be a fuel transfer tube located on the bottom side of the assembly. Release this connection and let it fall back into the tank. The figure below gives you a visual on the internal working of your fuel tank. **FIGURE 1-3**

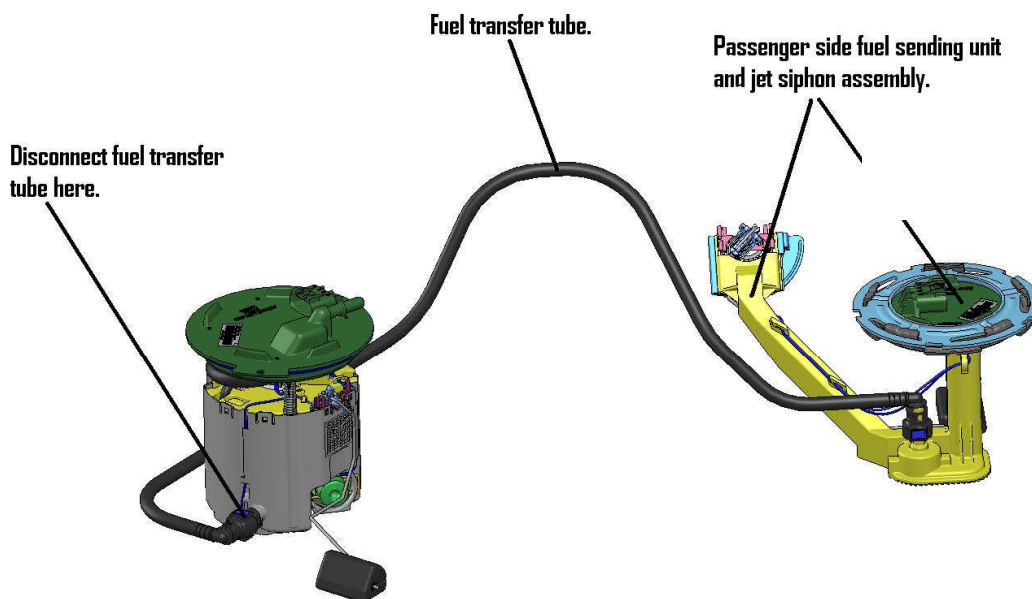

FIGURE 1-3

13. With the fuel pump assembly removed from the tank, remove the fuel level sensor. **FIGURE 1-4**

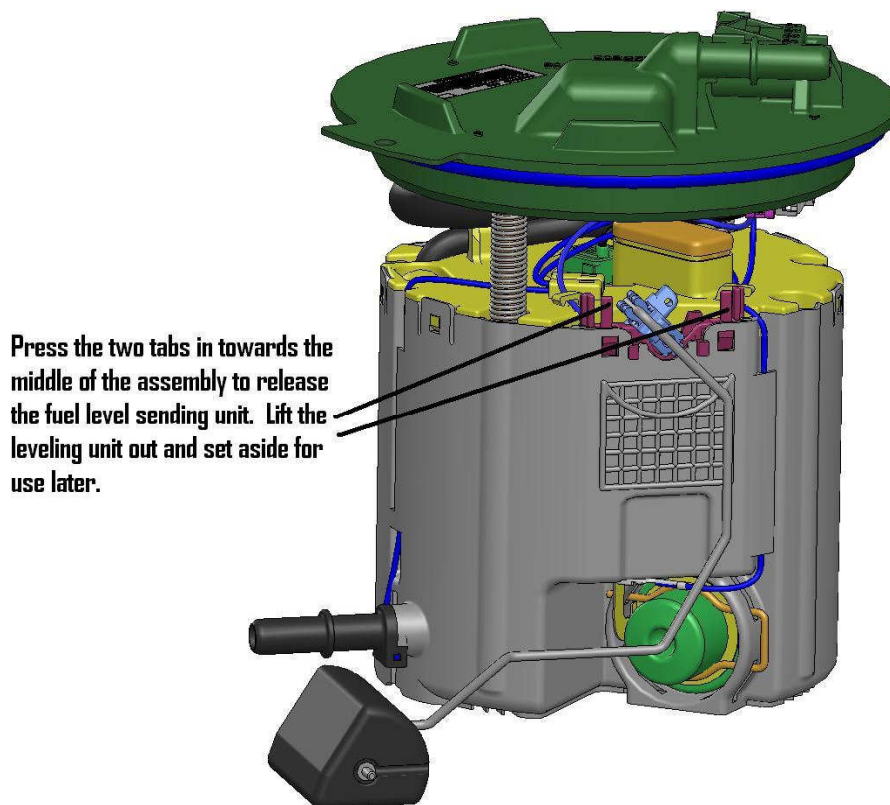

FIGURE 1-4

14. Now take Aeromotive fuel pump assembly and slide the leveling unit into it as illustrated in **FIGURE 1-5**. **NOTE:** When twisting the bottom tabs inward, be sure not to twist them into the wires on the bottom of the leveling unit. Move the leveling arm through it's full range of motion to ensure it clears the bracket tabs.

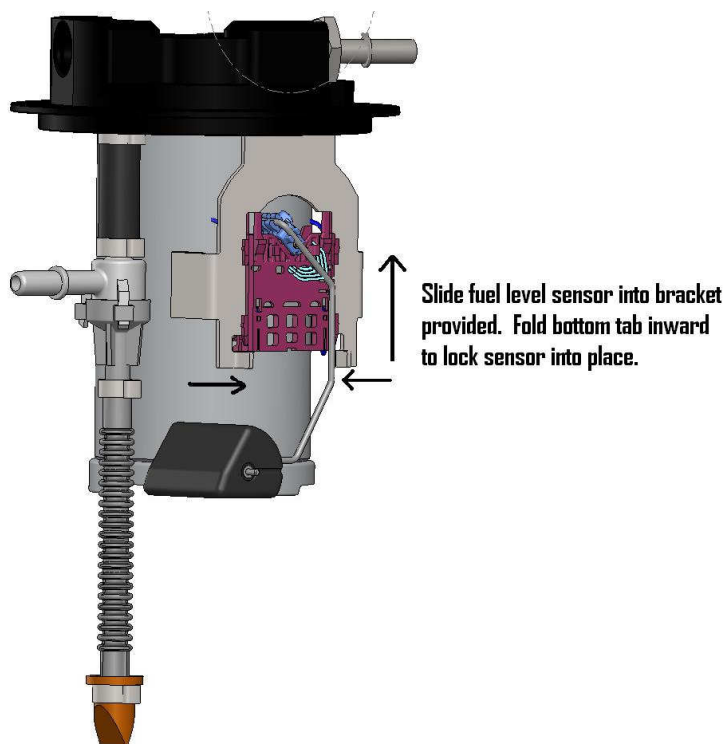

FIGURE 1-5

15. Cut the two wire connector off of the fuel level sensor and crimp them onto the two wires provide on the pump. **NOTE:** The sensor is a resistance output only, wiring polarity is bi-directional.
16. Make sure to place the factory o-ring in the receiver groove on the tank **Figure 1-6**. Failure to do so will result in fuel leakage and require removal of the tank again.

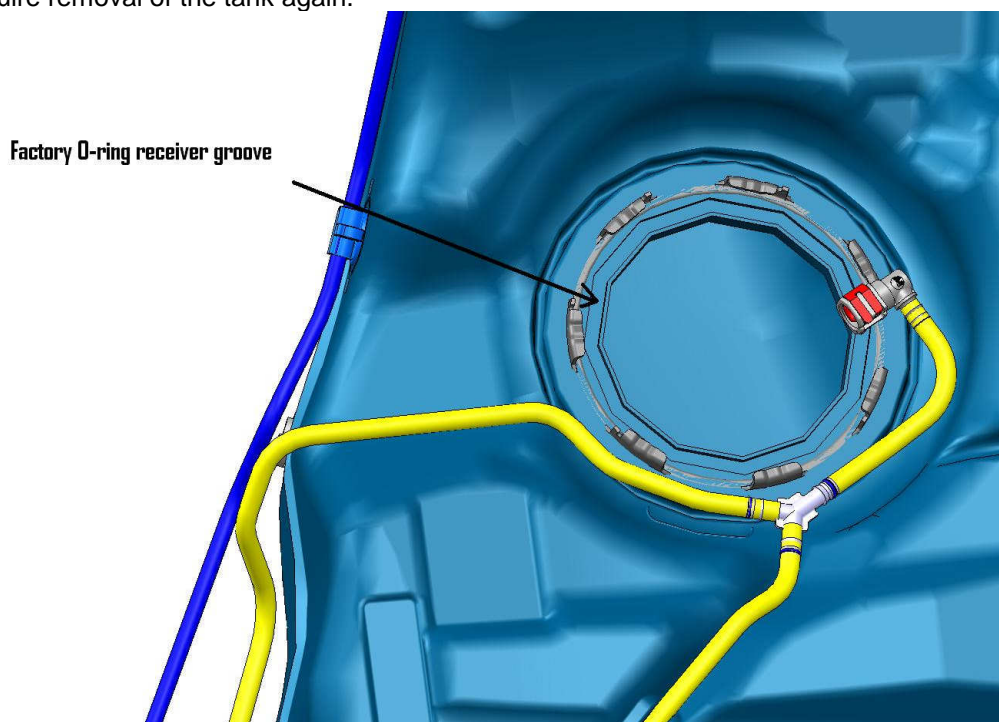
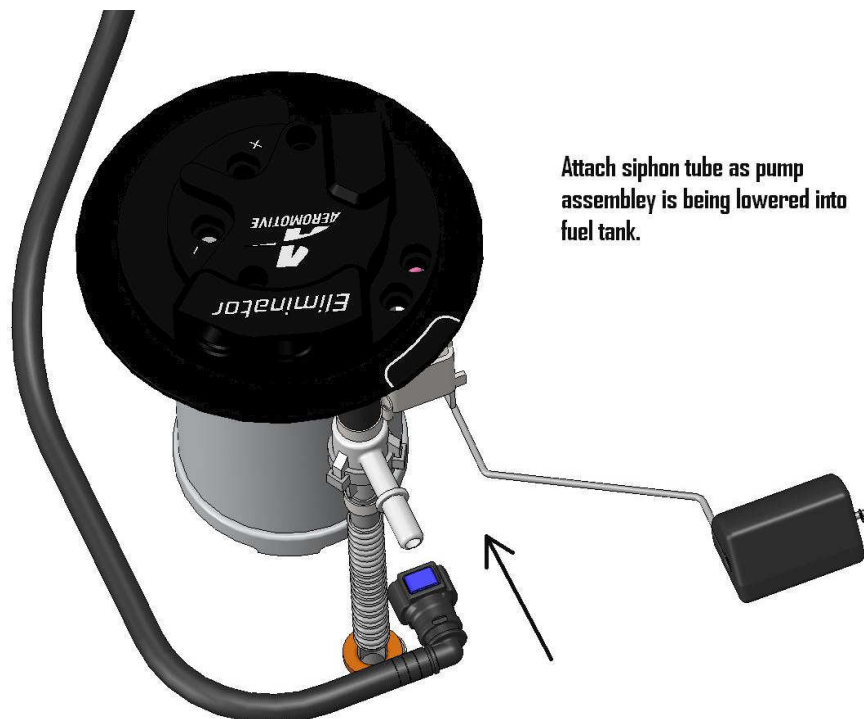

FIGURE 1-6

17. Now the fuel pump is ready to install in the tank. The siphon connection has to be made as the fuel pump is being lowered into the fuel tank. **FIGURE 1-7.** **NOTE: Bend the flex hose with the orange check valve on the Aeromotive pump assembly, so it points toward the float level.**



Attach siphon tube as pump assembly is being lowered into fuel tank.

FIGURE 1-7

18. Use the positioning marks on the pump to align the unit. **FIGURE 1-8.** Replace the lock ring on the top of the fuel pump assembly and rotate it to the “locked” position. If re-using the factory feed line, attach it to the Aeromotive pump at this time. **NOTE: You must install a by-pass style regulator with return line in order for the fuel pump to function correctly. Failure to do so will result in poor performance and fuel pump/system failure.**

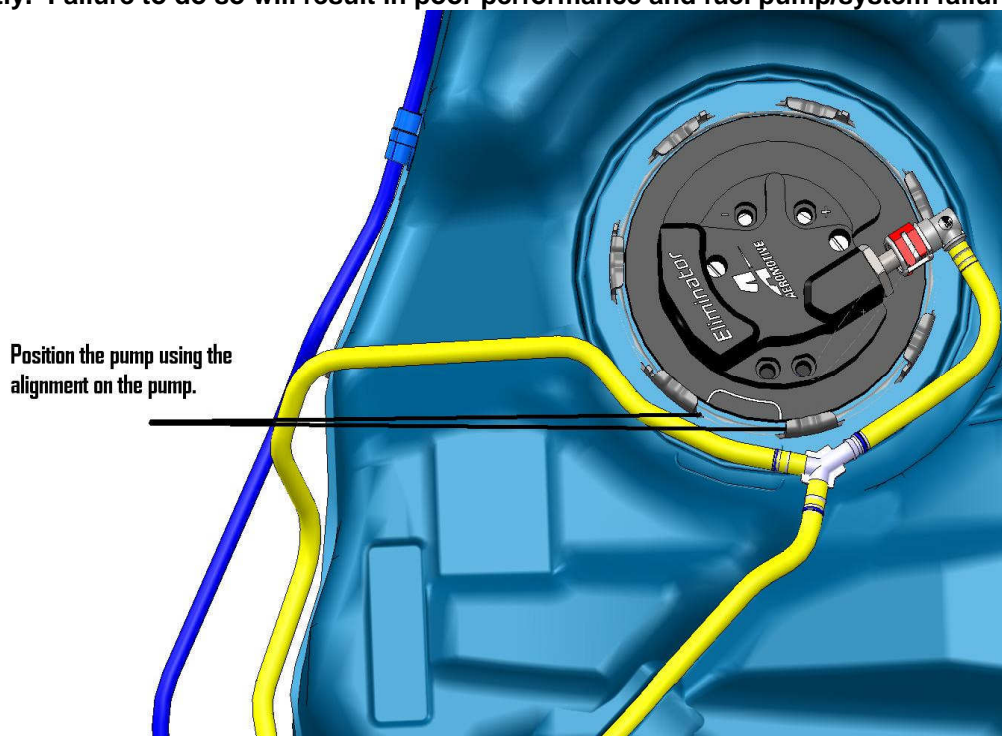

Position the pump using the alignment on the pump.

FIGURE 1-8

19. Affix the supplied foam strip to the top of the tank as shown in **FIGURE 1-9**.

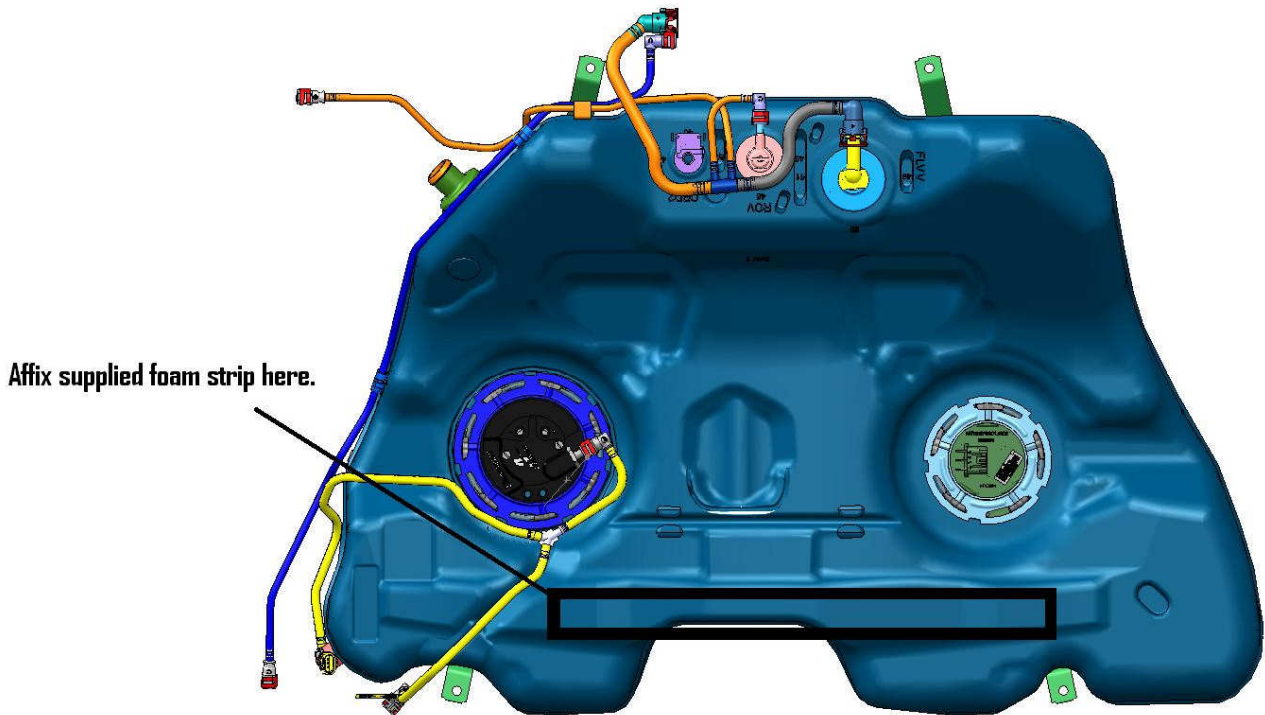
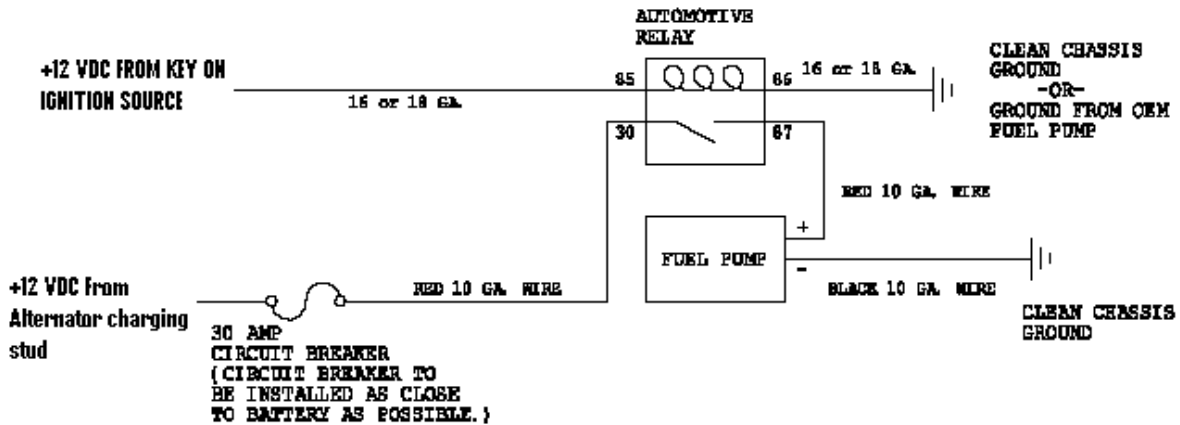

FIGURE 1-9

20. Cut or splice the factory fuel level wires and attach them to the fuel level studs. Make sure you use stranded, insulated copper wire, with matching crimp-type connectors for all connections. Use the supplied rubber terminal boots to protect the terminals from the elements. **NOTE: Position the fuel tank under the vehicle and allow yourself enough room to make the wire connections.**

21. Since the factory GM fuel pump is pulse modulated you can not use the factory fuel pump wires to trigger the relay. Find a suitable 12V key on ignition source for the #85 connection on the relay.

Hooking the factory wiring directly up the Aeromotive unit could result in wiring damage or pump failure.



22. Now the fuel tank is ready to be installed in the vehicle. Attach the return line to the Aeromotive top plate before installing the tank (15605 for the 18673 and 15607 for the 18674). Coil the return line up to keep it out of your way. Take the supplied fuel tank spacers and place them between the tank straps and body. See **FIGURE 1-13**.

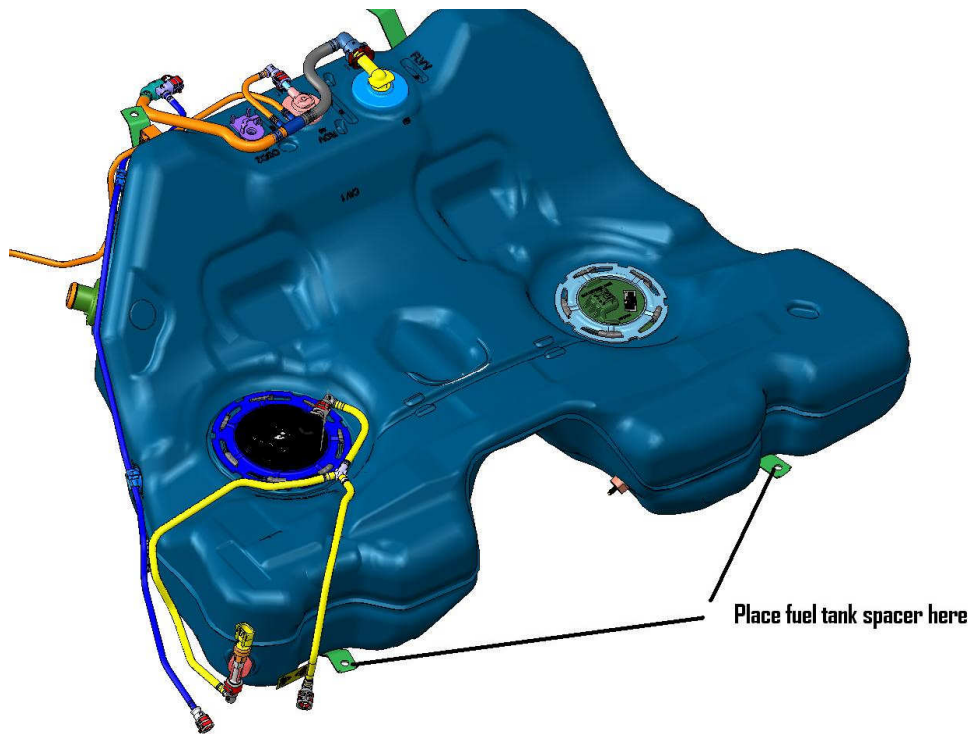

FIGURE 1-13

23. Now reverse steps 12-1 to finish up the tank installation.
24. Route the return line under the vehicle noting to keep it away from heat and moving suspension components.
25. Find a suitable place in the engine bay to mount a return style regulator. Plumb the regulator per the manufactures installation instructions.
26. Key on to check for leaks and to set fuel pressure. If any leaks are found, immediately discontinue use of vehicle and repair the leak(s)! This finishes up the installation of your new Aeromotive Stealth fuel pump.



WARNING: This product can expose you to chemicals, including chromium, which is known to the State of California to cause cancer or birth defects or other reproductive harm. For more information, visit: www.p65Warnings.ca.gov

AEROMOTIVE, INC. LIMITED WARRANTY

This Aeromotive Product, with proof of purchase dated on or after January 1, 2003, is warranted to be free from defects in materials and workmanship for a period of one year from the original date of purchase. No warranty claim will be valid without authentic, dated proof of purchase.

This warranty is to the original retail purchaser and none other and is available directly from Aeromotive and not through any point of distribution or purchase.

If a defect is suspected, the retail purchaser must contact Aeromotive directly to discuss the problem, possible solutions and obtain a Return Goods Authorization (RGA), if deemed necessary by the company. Please call 913-647-7300 and dial option 3 for the technical service dept. All returns must be shipped freight pre-paid to the company and with valid RGA before they will be processed.

Aeromotive will examine any product returned with the proper authorization to determine if the failure resulted from a defect or from abuse, improper installation, misapplication or alteration. Aeromotive will then, at it's sole discretion, return, repair or replace the product.

If any Aeromotive product is determined defective, buyer's exclusive remedy is limited in value to the sale price of the good. In no event shall Aeromotive be liable for incidental or consequential damages.

Aeromotive expressly retains the right to make changes and improvements in any product it manufactures and sells at any time. These changes and improvements may be made without notice at any time and without any obligation to change the catalogs or printed materials.

Aeromotive expressly retains the right to discontinue at any time and without notice any Aeromotive product that it manufactures or sells.

This warranty is limited and expressly limits any implied warranty to one year from the date of the original retail purchase on all Aeromotive products.

No person, party or corporate entity other than Aeromotive shall have the right to: determine whether or not this Limited Warranty is applicable to any Aeromotive product, authorize any action whatsoever under the terms and conditions of this Limited Warranty, assume any obligation or liability of any nature whatsoever on behalf of Aeromotive under the terms and conditions of this Limited Warranty.

This Limited Warranty covers only the product itself and not the cost of installation or removal.

This Limited Warranty is in lieu of and expressly excludes any and all other warranties, expressed or implied. This Limited Warranty gives you specific legal rights, and you may also have other rights which vary from state to state.