



AEROMOTIVE
Part # 18096/18097

**2006+ Charger/2008+ Challenger/2005+ Chrysler
300C/05-08 Dodge Magnum Dual and Triple Pump
INSTALLATION INSTRUCTIONS**

This product is not legal for sale or use on emission-controlled vehicles except when used as a direct replacement part matching OEM specification.

WARNING!



Always be aware of flammable situations. Drilling and grinding can be potential ignition sources. Extinguish all open flames, prohibit smoking and eliminate all sources of ignition in the area of the vehicle and workspace before proceeding with the installation. Ensure you are working in a well-ventilated area with an approved fire extinguisher nearby.

WARNING!



Installation of this product requires modification to a fuel tank/ the fuel system, failure to satisfy all safety considerations will result in fire, explosion, injury and/or loss of life to yourself and/or others. All fuel system components **MUST** be located as far from heat sources as possible, like exhaust, engine block, etc.

WARNING!



Mechanical and hydraulic lifting devices can tip over or lower accidentally due to incorrect maneuvering or technical errors. A falling object can cause injury and/or loss of life to yourself and/or others. When working under the vehicle, always use stands, and ensure that the ground or floor is stable and level. Never crawl under a vehicle which is only supported by a jack.

WARNING!



The fuel system is under pressure. Do not open the fuel system until the pressure has been relieved. Refer to the appropriate vehicle service manual for the procedure and precautions for relieving the fuel system pressure.

CAUTION!



When installing this product always wear safety glasses and other appropriate safety apparel. A drilling operation will cause flying metal chips. Flying metal chips can cause eye injury.

CAUTION:



Installation of this product requires detailed knowledge of automotive systems and repair procedures. We recommend that this installation be carried out by a qualified automotive technician. Careless installation of this product can result in damage to the product, injury or loss of life to yourself and/or others.

Compatible Fuels:

Pump Gas
Race Gas
E85

Aeromotive system components are not legal for sale or use on emission-controlled motor vehicles.

This pump assembly is a high-performance factory replacement unit. Key features:

- **Drops directly into the factory fuel tank (NO CUTTING REQUIRED).**
- **Utilizes OEM jet siphon in conjunction with factory jet siphon system plumbing.**
- **High flow pre-filter built into inlet of pump(s).**
- **Includes fuel level mounting bracket for factory fuel level sending unit.**

NOTE: The use of Teflon braided line with machine crimped hose ends is recommended. This eliminates the possibility of fuel vapors permeating through the fuel line.

Maximum continuous operating pressure should not exceed 65 psi.

The enclosed Aeromotive fuel pump utilizes AN-08 ORB (O-ring Boss Port) style for the outlet and -08 ORB for the return and vent ports; these ports are **NOT PIPE THREAD** and utilize **NO THREAD SEALANT**.

Pump Specifications:

	18096 Kit (Pump 2x #11145)	18097 Kit (Pump 3x #11145)
Outlet pressure/typical flow:	40 psi / 2x 381 LPH @ 13.5 V 60 psi / 2x 324 LPH @ 13.5 V	40 psi / 3x 381 LPH @ 13.5 V 60 psi / 3x 324 LPH @ 13.5 V
Continuous Operating Range:	30 psi – 65 psi @ 13.5 V	30 psi – 65 psi @ 13.5 V
Pump internal By-Pass Pressure:	120 psi	120 psi
Current Draw:	2x 15.3 amps @ 40 psi	3x 15.3 amps @ 40 psi

Aeromotive Related Components:

Fuel Filters:

12341 10 micron microglass ORB-12
12350 10 micron microglass ORB-10
12305 filter bracket

Check Valves:

15107 (10AN)

Fuel Pressure Regulators:

13305 (-8 ORB ports)

Fuel Pressure Gauge:

15633 (dry 0-100psi)

Outlet Cap Port Fittings:

15607 (-8 ORB x -8 AN Male)

Electrical Components:

16307 (30A pump wiring kit)
16308 (60A pump wiring kit)

1/2" Quick Connect Cap Fitting:

180-96D1-0F (3/8" Quick Connect Female Cap)

NOTE:This pump module installation requires an experienced tuner/installer that is familiar with integrating the OEM pulse width modulation system with a supplemental fuel system. This system is intended to fuel both the OEM pulse width modulation system in conjunction with a supplemental fuel system. Integrating the pulse width modulation wiring and plumbing with the supplemental wiring and plumbing should only be done by an experienced tuner/installer. Upgraded wiring is required to power the fuel pumps installed on this pump module. 10 gauge wire is recommended for powering an individual pump and 8 gauge wire is recommended for powering two pumps simultaneously. Part number 18097 (Triple 450 Pumps) requires 8 gauge wire to power the "Aux" terminals.

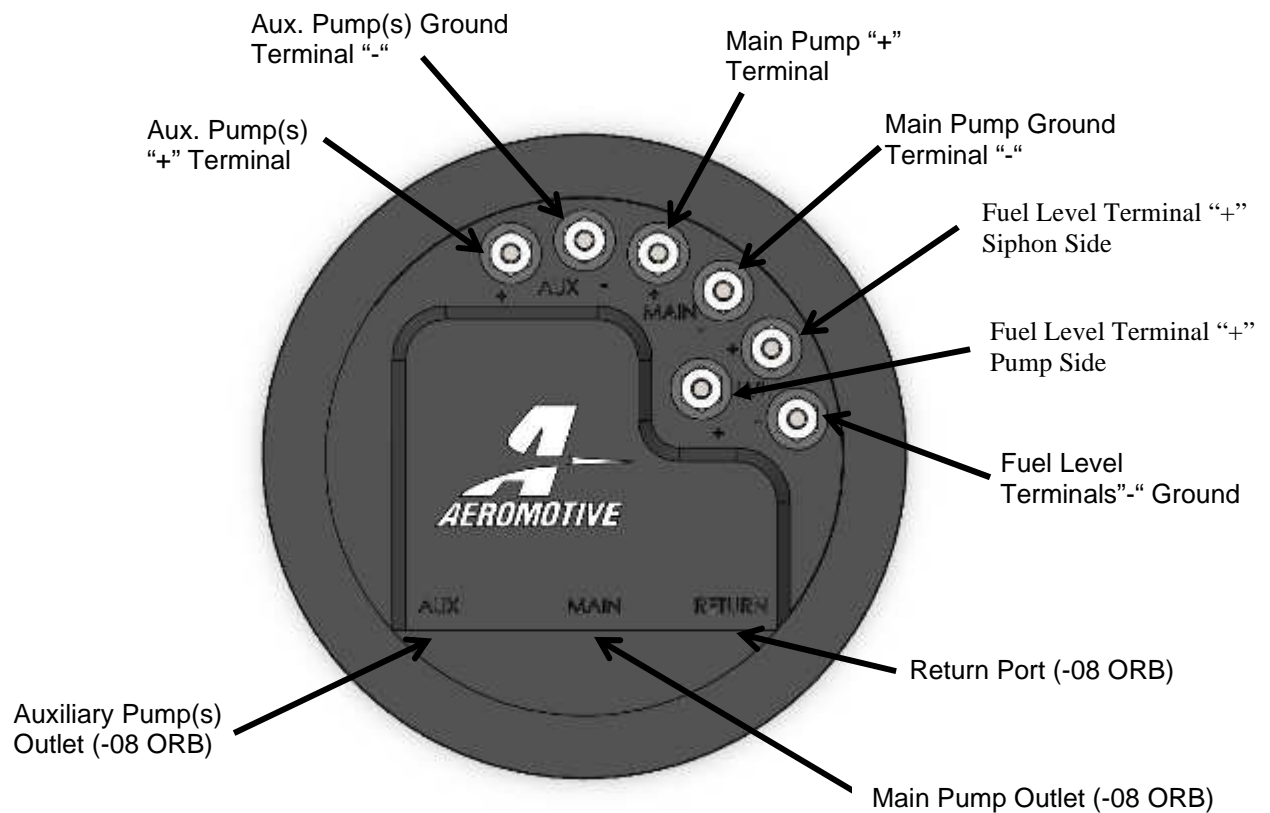

OUTLET CAP LAYOUT

The following steps are typical of most installations:

1. Drain the fuel tank, relieve system pressure (refer to service manual for proper procedure), and disconnect the battery.
2. Remove the fuel tank from the vehicle following the manufacturer's suggested procedure (refer to service manual for proper procedure).
3. Remove the fuel line and vent tube by pressing the tabs on the quick connect fittings and unplug the wire connectors. Be sure to not damage the vent tube as this will be reconnected during the tank re-installation. Wipe the top of the fuel pump module clean to limit the amount of dirt and debris that can fall into the tank.

Fuel Pump Module

Fuel Tank Siphon
Module/Fuel Line Outlet



Vent Tube – Remove and set aside
for later reinstallation.

4. Using the supplied 3/8" Quick Connect Cap fitting, install the cap fitting on the OEM fuel pump outlet fitting located on the Fuel Tank Siphon outlet cap. Push the fitting on the male quick connect fitting until an audible "click" is heard. Ensure the cap is on securely. **Note: O-ring lubricant is useful when installing the cap fitting over the fuel pump outlet fitting.** The Aeromotive fuel pump module changes the fuel pump outlet from the passenger side of the tank to the driver's side of the tank. The Quick Connect Cap is required for the new pump system to operate correctly. See pictures below.



Install 3/8" Quick Connect Cap on
OEM fuel pump outlet fitting.

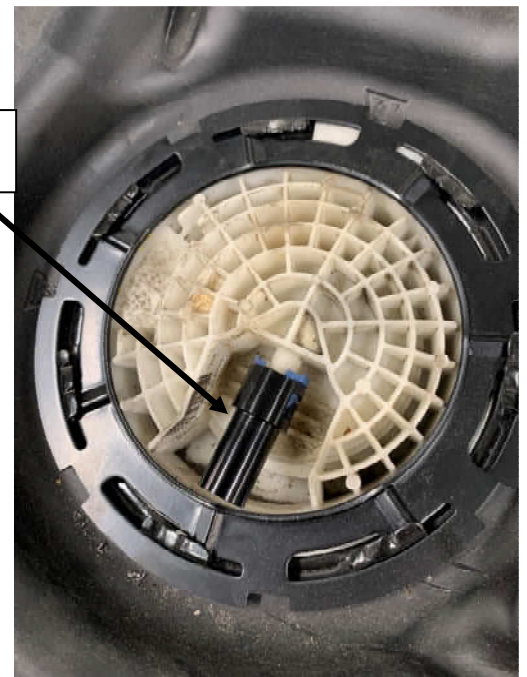

CAUTION: Immediately wipe up any fuel spills from the hoses.

5. Remove the OEM lock ring from the fuel pump module side of the tank. Set the lock ring aside as it will be used during re-assembly. Once the lock ring is removed, pull up on the outlet cap and unplug the electrical connector(s) on the bottom of the outlet cap by pressing down on the small plastic tabs. One connector is for the fuel pump and fuel pump side fuel level sender, the other connector is for the siphon side fuel level sender. Fully remove the outlet cap from the bottom of the fuel pump module. See pictures below.



Remove OEM lock ring from Fuel Pump Module side only.

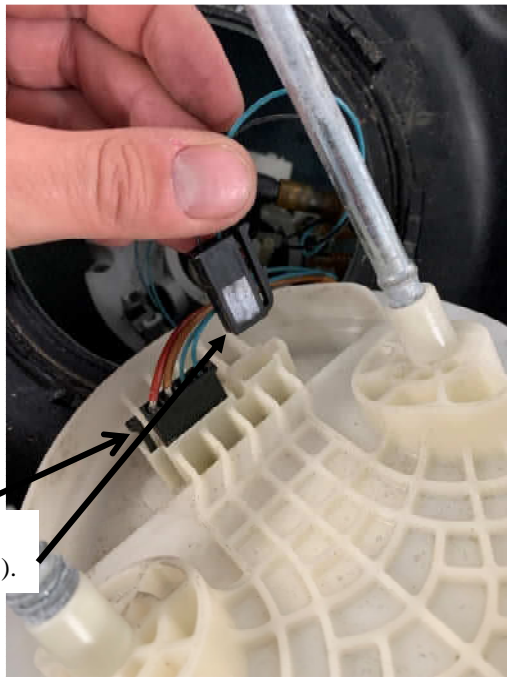

Depress the plastic tab to remove the electrical plug(s).

- Next, disconnect the internal siphon feed/pump outlet feed line. To do this press the two plastic tabs on either side of the quick connect fitting and pull backwards to release it from the quick connect fitting attached to the fuel pump module lower section. Note: Use care to not destroy or damage the quick connect fitting during disassembly as this is needed during reassembly. See picture below.



Internal Siphon Return Line/Over-Pressure Line – Remove from plastic clips.

Disconnect Siphon Feed/Pump Outlet Feed Line from male quick connect fitting on lower fuel pump module.

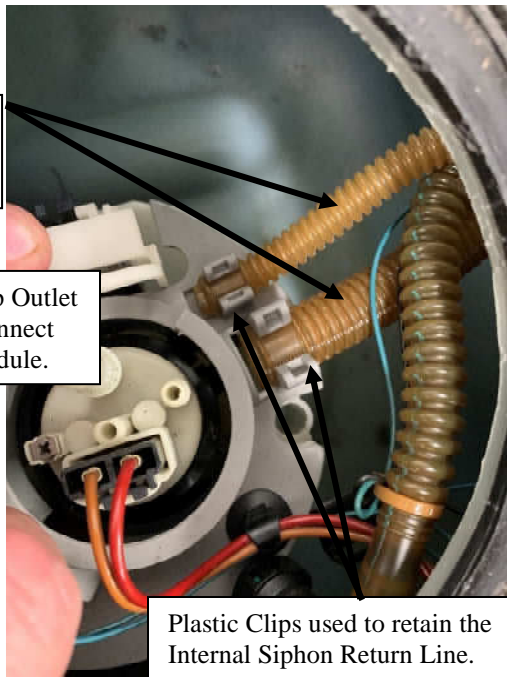

Plastic Clips used to retain the Internal Siphon Return Line.

- Next, disconnect the internal siphon return line and siphon over-pressure line. To do this, simply pull up on the tube to release it from the plastic clip attached to the fuel pump module lower section. Note: Use care to not destroy or damage the siphon return hose or over-pressure hose during disassembly as this is needed during reassembly. See picture above.
- Carefully remove the lower portion of the fuel pump module from the tank. Do not damage the fuel level sender as this will be reused during reassembly.

- Once the lower portion of the fuel pump module is out of the tank, cut the two fuel level sender wires from the electrical connector, (the wires are normally green in color). Next, remove the fuel level sender from the lower fuel pump module. To do this, depress the small plastic tabs as shown in the picture below and slide the fuel level sender off the mount. See pictures below.

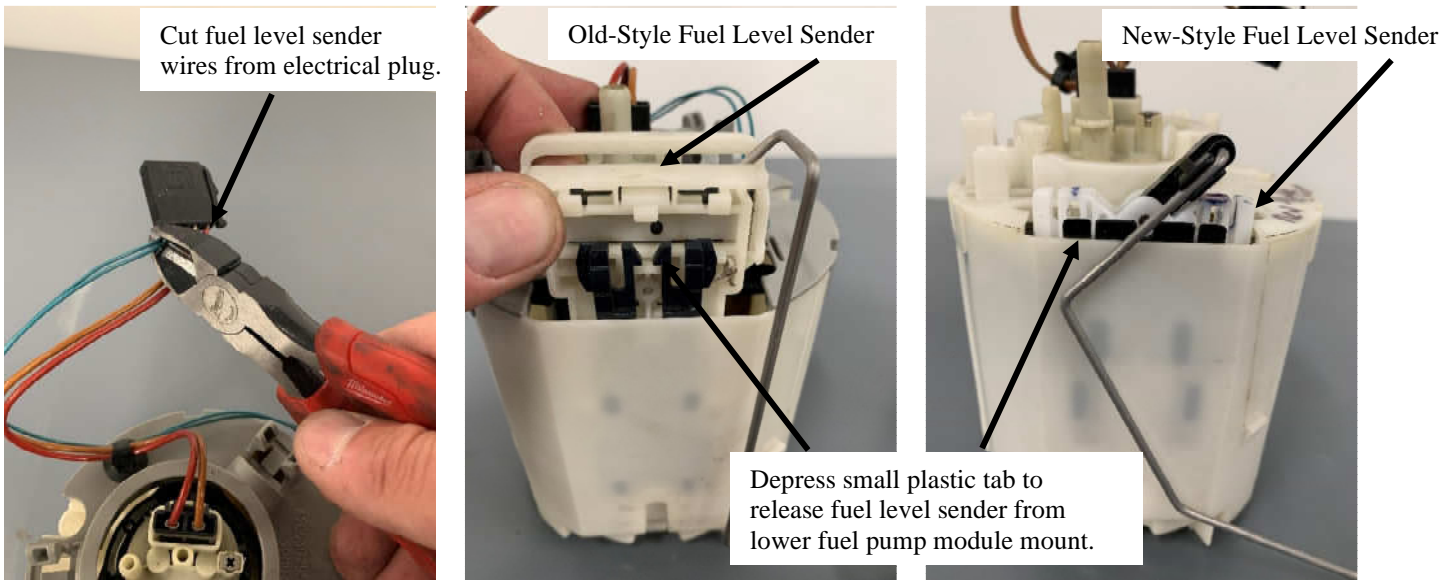

Note: There are two different types of OEM fuel level senders used with these fuel pump assemblies. Your vehicle can have either an "old-style" or "new-style" sending unit. The Aeromotive pump assembly includes fuel level sender brackets to accommodate either of the level sender styles. Depending on which style your vehicle has, you will need to follow the appropriate instructions below to properly remove and attach the fuel level sender to the new Aeromotive pump assembly.

- Once the lower portion of the fuel pump module has been removed from the tank, you can determine which fuel level sender type you have. The different configurations are shown in the picture below.

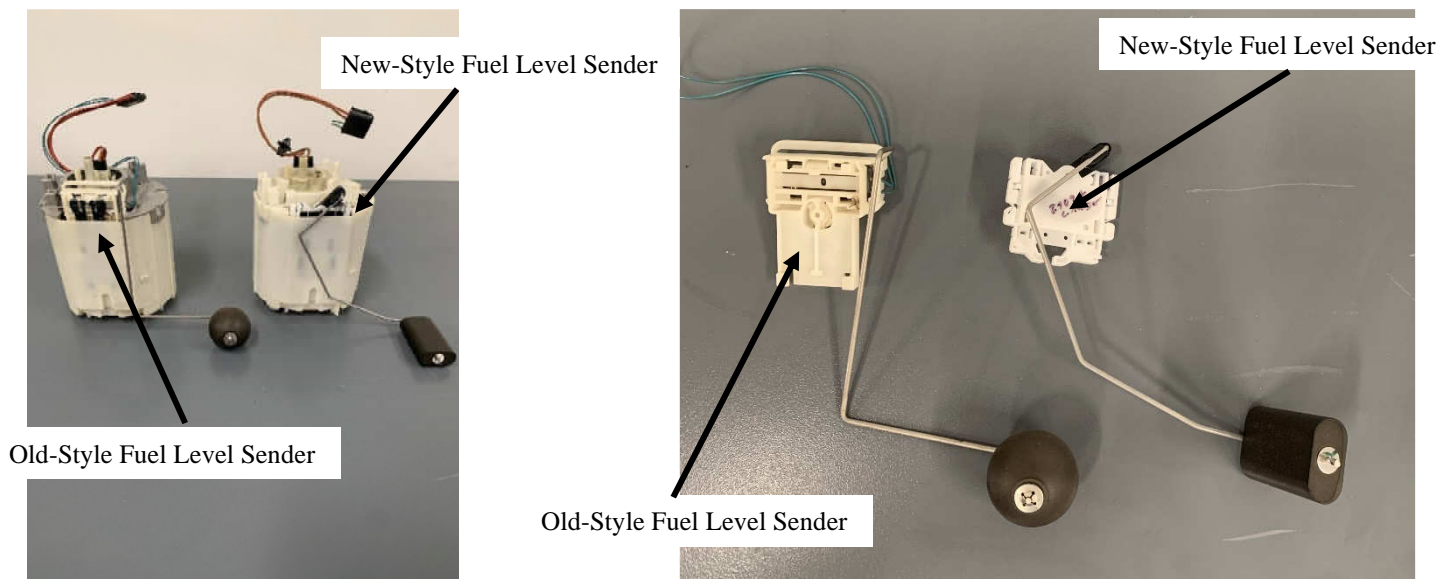

- Once the fuel level sender is removed from the OEM fuel bucket assembly you are ready to install it on the provided fuel level sender bracket. There are two sending unit brackets provided with the Aeromotive fuel pump assembly. Select the corresponding fuel level sender bracket to use with your style of fuel level sender. See the pictures below of the different types of included brackets.

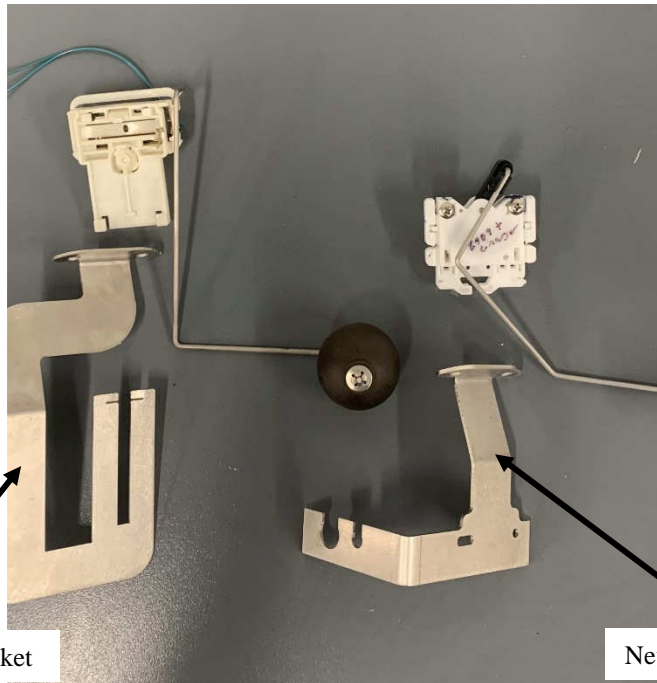

Old-Style Fuel Level Sender Bracket

New-Style Fuel Level Sender Bracket

12. First, we will show installation of the old-style fuel level sender on the bracket. To install the level sender on the bracket, slide the fuel level sender on the two tabs or fingers of the old-style level sender bracket as shown in the pictures below.

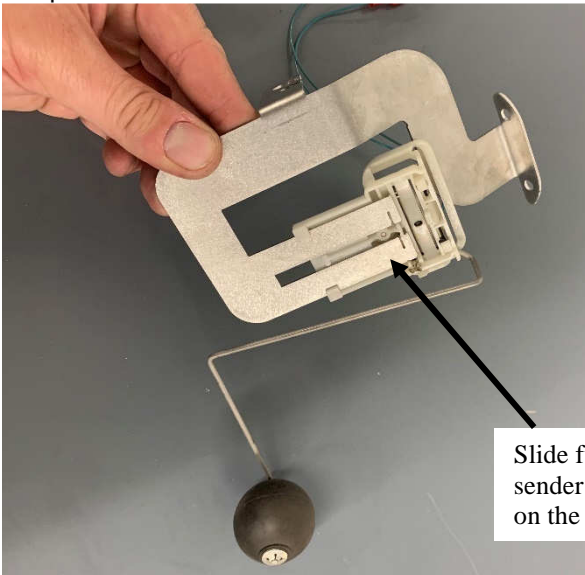

Slide fuel level sender over "fingers" of the level sender bracket until the level sender bottoms out on the bracket.

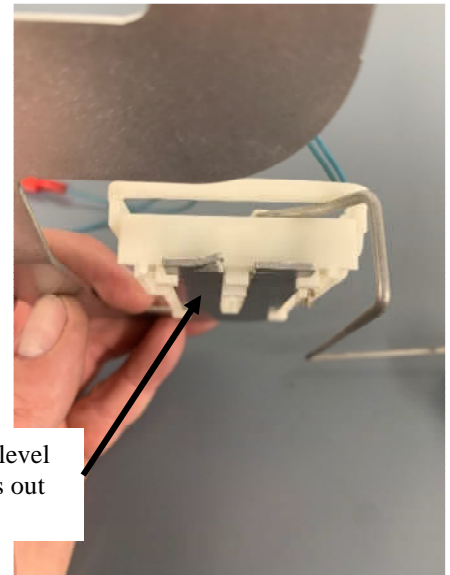

13. Once the level sender is bottomed out on the bracket, use a pair of needle nose pliers to put a slight bend in the two small tabs on the top of the metal "fingers" of the bracket. You will bend them slightly over the top of the plastic fuel level sender. This retains the level sender from moving once immersed in fuel. See the picture below.

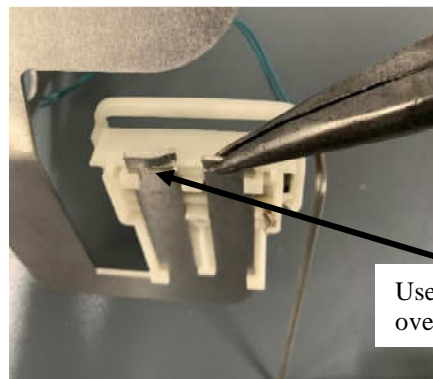

Use needle nose pliers to bend the tabs slightly over the plastic fuel level sender.

14. Next, we will show the process of installing the new-style fuel level sender on its corresponding bracket. First, using the two provided 6-32 truss head screws, thread them through the rectangular holes from the front of the level sender. Then, install two of the provided 6-32 nuts on the back side of the level sender as shown in the pictures below.

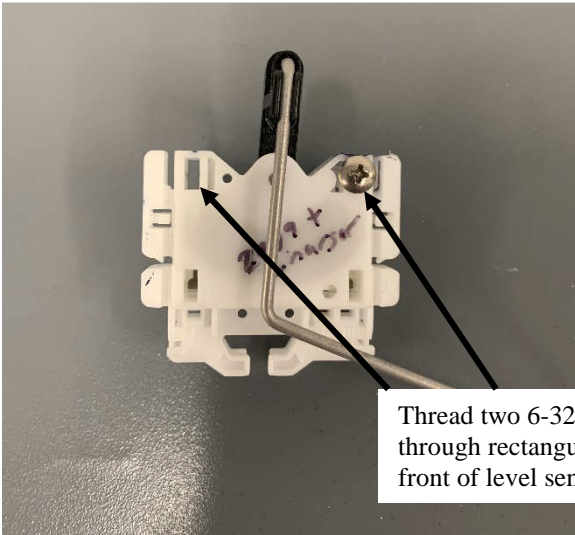

Thread two 6-32 screws through rectangular holes from front of level sender.

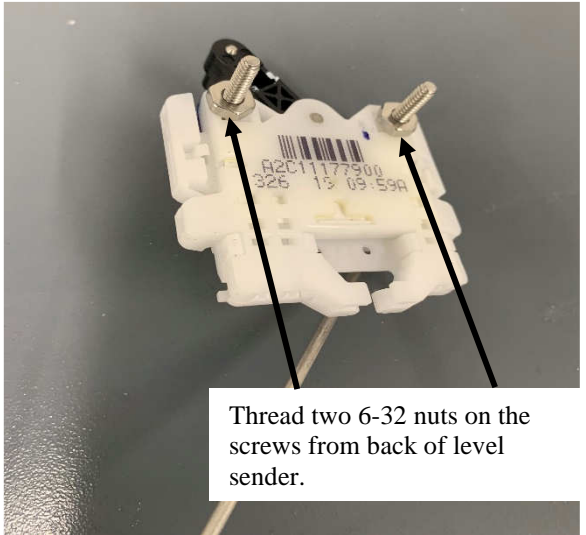

Thread two 6-32 nuts on the screws from back of level sender.

15. Install the fuel level sender on the new-style fuel level sender bracket. Once the level sender is on the bracket, use the provided 6-32 washers, lock washers, and nuts to secure the level sender to the bracket. See pictures below.

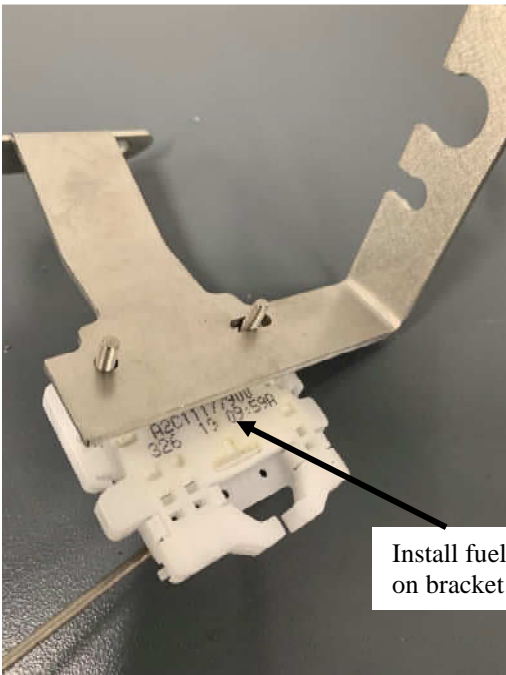

Install fuel level sender on bracket as shown.

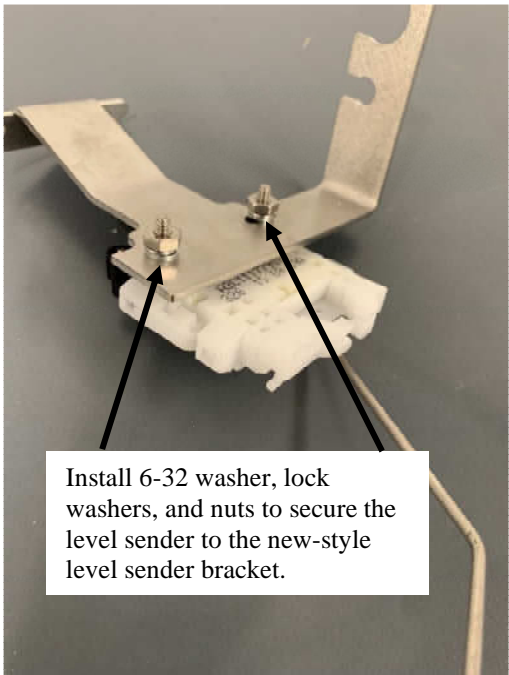

Install 6-32 washer, lock washers, and nuts to secure the level sender to the new-style level sender bracket.

16. Next, strip the ends of the two fuel level sender wires and crimp on the provided male spade connectors. You are now ready to install the fuel level sender on the bracket attached to the new Aeromotive fuel pump assembly. See pictures below.

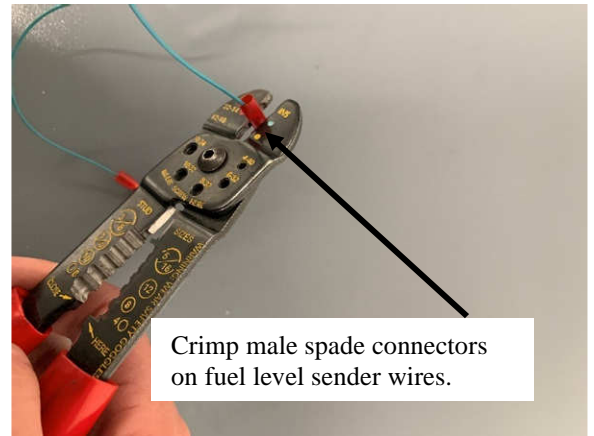
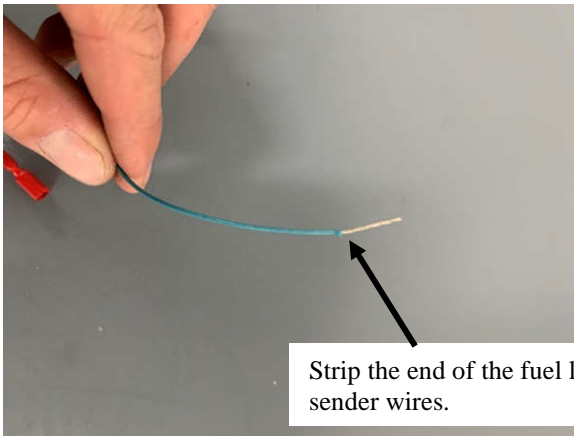

17. Once the provided male spade connectors are crimped on the fuel level sender wires you will now locate the two wires inside the tank that are tied to the siphon return and siphon over-pressure line. Cut the OEM electrical connector off, leaving as much wire length as possible. Strip the two wires and crimp on the remaining two male spade connectors as they will be connected to the outlet cap of the new Aeromotive fuel pump assembly in the upcoming steps. See pictures below.



18. Next, install the applicable fuel level sender bracket on the bottom of the outlet cap using the provided 10-24 socket head cap screws and lock washers. **Note: (Old-Style level sender bracket shown for the remainder of the assembly process. The process is the same with the New-Style level sender bracket.)** See pictures below.

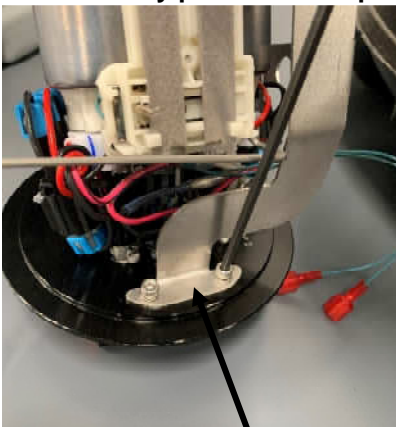

Install fuel level sender bracket on outlet cap with socket head cap screws and lock washers.

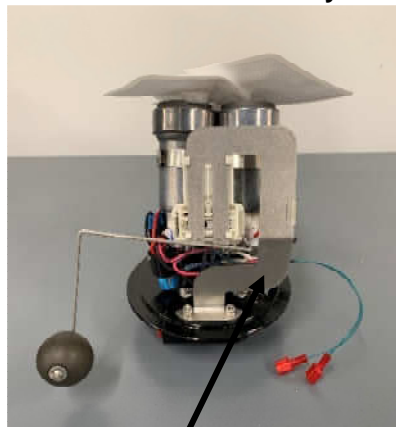

Installed "Old-Style" fuel level sender bracket on outlet cap with socket head cap screws and lock washers.



Installed "New-Style" fuel level sender bracket on outlet cap with socket head cap screws and lock washers.

19. Connect the two male and female blade connectors from the pump side fuel level sender with the white wires from the "LVL +" and "LVL -" terminals on the bottom of the outlet cap. **Ensure the pump side fuel level sender wire is connected to the corresponding "LVL +" terminal as shown in the outlet cap layout at the beginning of the instructions. Note: The "LVL -" terminal is a shared terminal for both the pump side and siphon side fuel level sender ground. See picture below. Note: Route the wires from the fuel level sender and/or fuel pumps to ensure they are secure and do not interfere with the movement of the fuel level sender arm. Securing the wires with a small nylon cable tie may help keep the wires from interfering with the fuel level sender arm movement.**

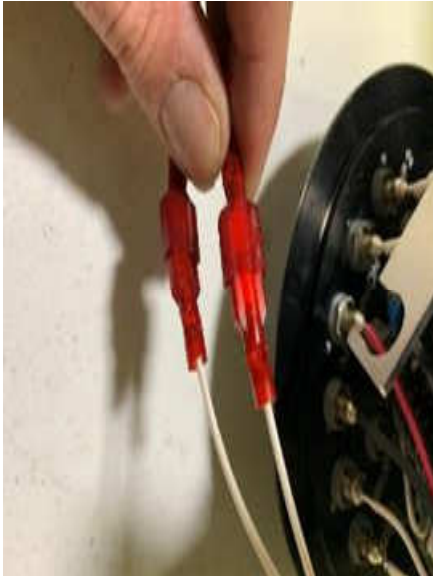

Two wires soldered to common terminal used for fuel level sender(s) ground "LVL -".

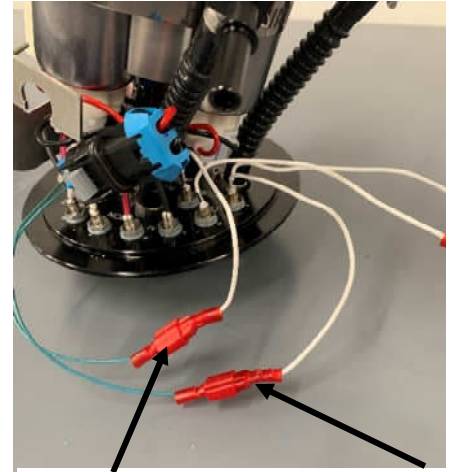

Connected pump side fuel level sender wires to the corresponding "LVL +" and "LVL -" wires.

20. If not already installed; install each fuel pump strainer (pre-filter) on each fuel pump and install a new fuel pump module gasket (not included).



Install new fuel pump module gasket (not included). Use Dorman PN: 911245 or equivalent.

21. Set the pump assembly near the fuel tank hole; there are three hoses inside the tank that will connect to the new fuel pump outlet cap. **Note: It is helpful to have a small wire with a hook on one end to help retrieve the hoses inside the tank.**

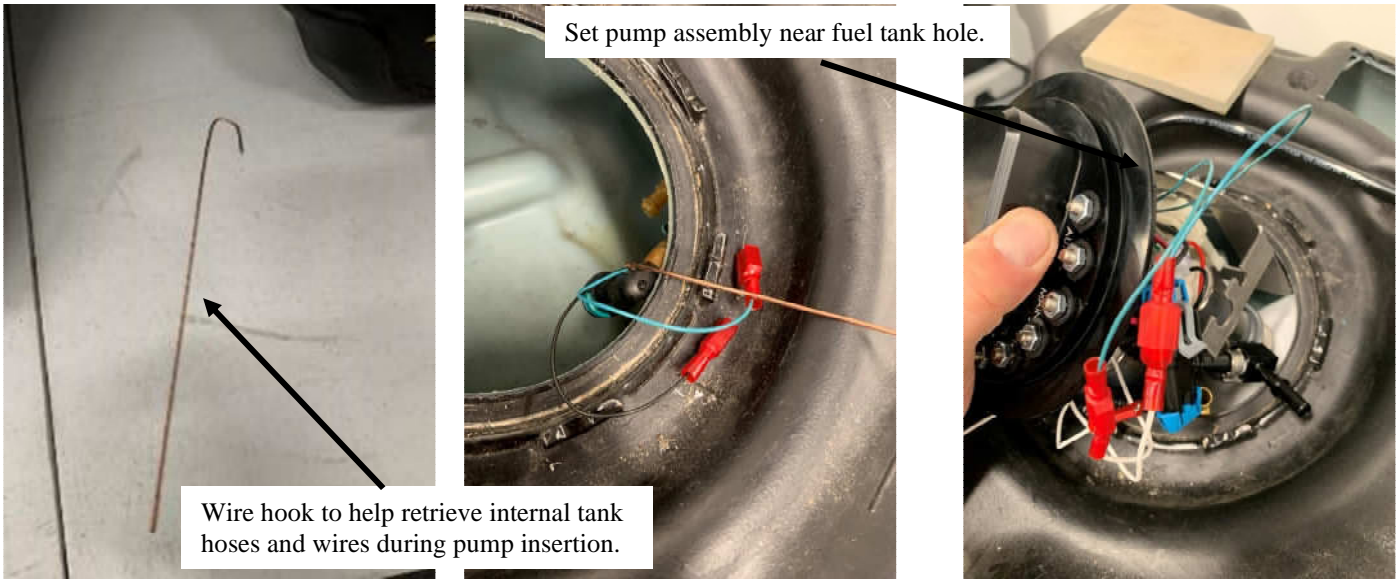

22. Locate the internal siphon feed/fuel outlet line and pull upwards towards the opening in the tank, the wire hook may be useful in this step. Align the siphon feed/fuel outlet line with the quick connect fitting attached to the outlet cap by the flexible black hose. Press the siphon feed/fuel outlet line on the quick connect fitting until and audible “click” is heard. Ensure the hose is firmly attached to the quick connect fitting. At this time, you will also connect the two fuel level sender wires from the siphon side of the tank using the provided spade connectors. The black wire should be connected to the second wire from the “LVL -“ terminal, and the green wire will be connected to the corresponding “LVL +” terminal spade connector. See pictures below.

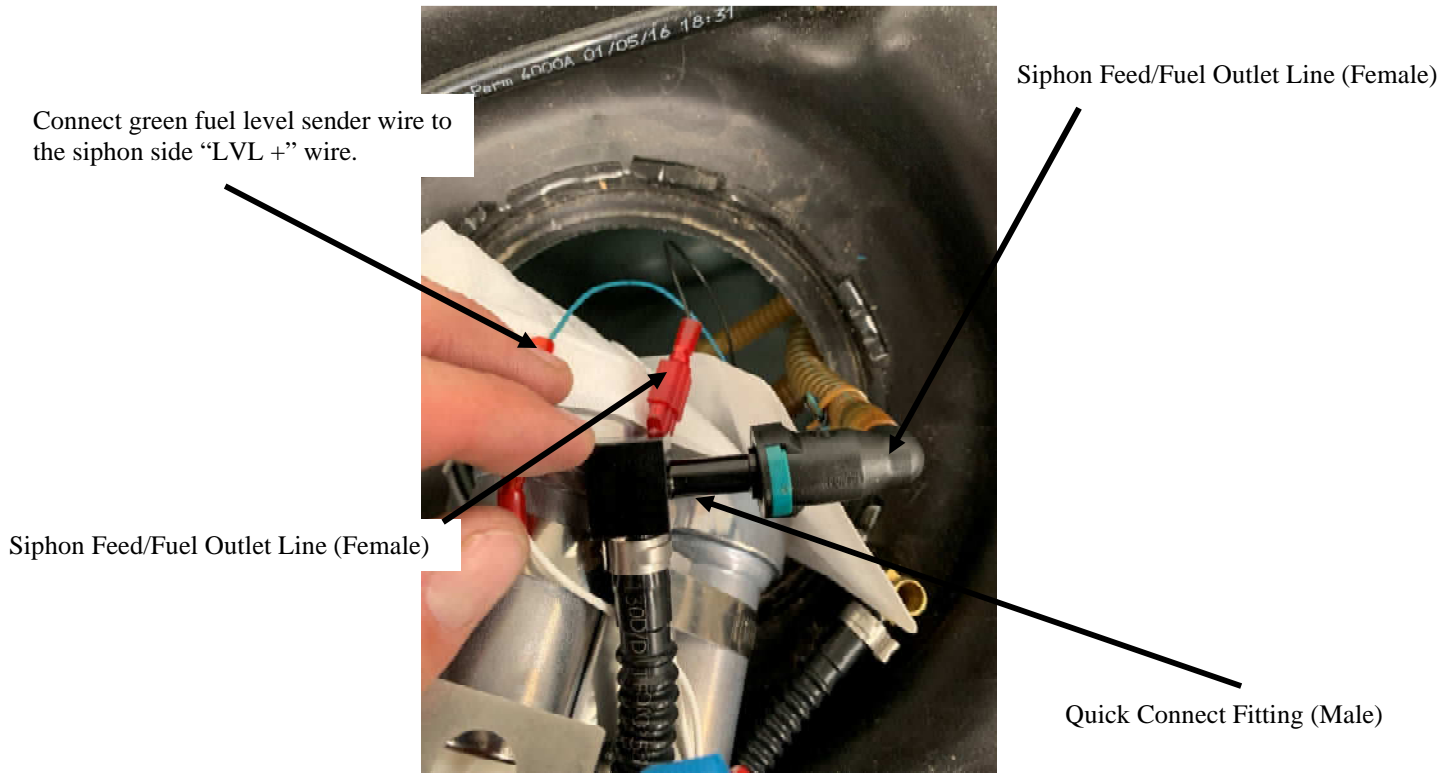

23. Next, carefully insert the pump assembly loosely inside the tank. Be careful not to damage the fuel level sender when inserting the pump into the tank. Then, using the wire hook, pull the siphon return hose and siphon over-pressure hose near the tank opening and position them over the top of the fuel level sender/hose retainer bracket. **Note: The bracket has two “U” shaped cutouts that are to retain the siphon return hose and the siphon over-pressure hose.**

24. Next, connect the siphon return hose and the over-pressure hose to the bracket that is attached to the pump assembly. The wire hook is useful to help retrieve this hose and get it into position. The hoses should be pushed down into the slot as shown in the below picture until it is retained.

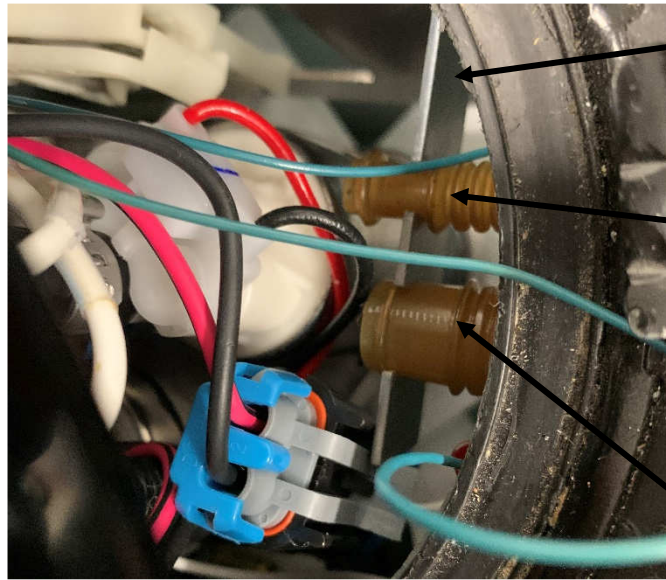

Bracket with slots for Siphon Return Hose.

Over Pressure Hose properly retained in the bracket slot.

Siphon Return Hose properly retained in the bracket slot.

25. You are now ready to fully install the fuel pump assembly into the tank. Push the fuel pump assembly down into the tank, ensure the gasket is properly placed in its groove. Orient the fuel pump outlet cap as shown in the below picture, then re-install the fuel pump lock ring.

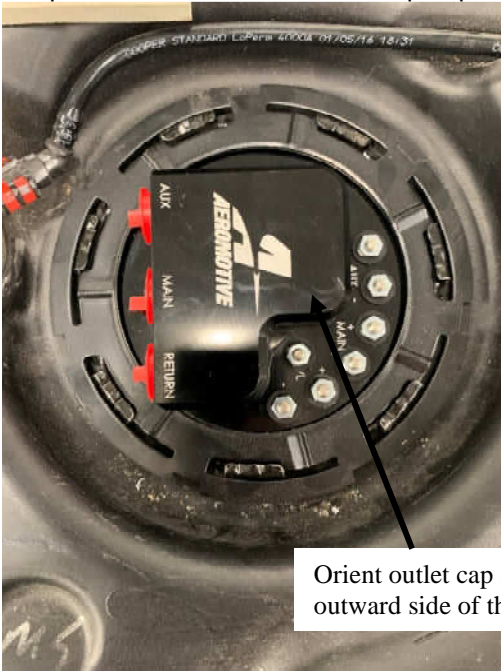

Orient outlet cap so the ports face the outward side of the tank as shown.



26. As mentioned above, upgraded wiring is required to power the new pumps, wiring the pumps to feed the OEM pulse width modulation fuel system to work in conjunction with a supplemental fuel system should only be performed by an experienced tuner/installer. Connect electrical power (12 VDC) to each of the fuel pump power terminals. Make sure you use stranded, insulated copper wire, in the sizes shown, with matching crimp-type connectors for all connections. **CAUTION: The pump must be connected through a fused power source and not connected directly to the battery.** Connect each of the Aeromotive fuel pumps as shown in the following diagram: **NOTE: ONE RELAY AND FUSE PER PUMP "SIDE" (MAIN OR AUXILIARY TERMINALS).**

27. **Note:** Test the function of the fuel level sender before fully installing the tank in the car, test the sending unit to ensure it has its full range of motion.

Wiring (per Pump)

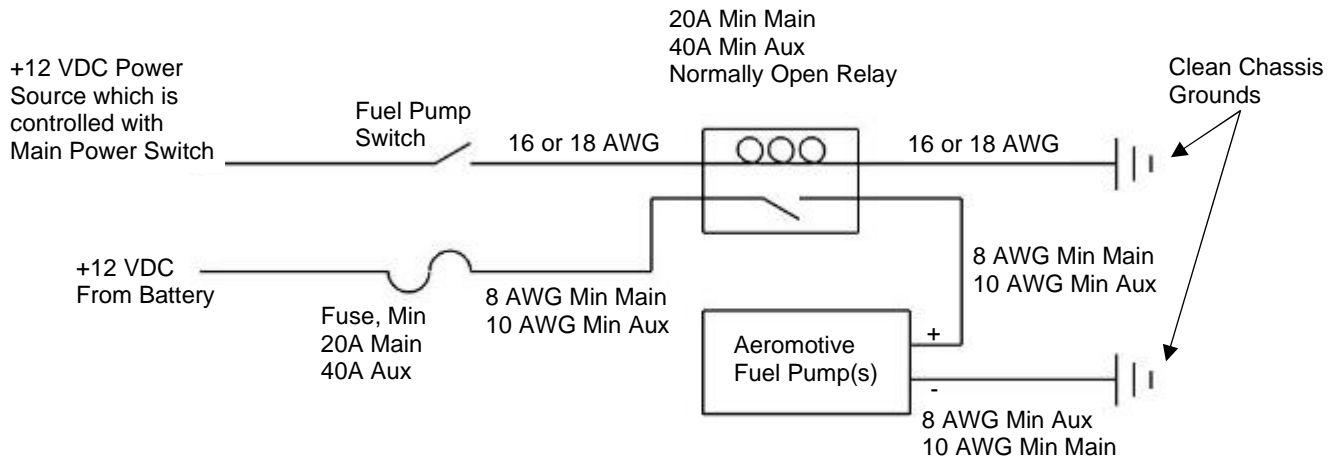

28. Run all necessary increased/upgraded plumbing and wiring to the outlet cap. **Note: A 45-degree -08 hose end works best to route the fuel feed lines out of the outlet cap. A 45-degree -08 hose end works best to route the return fuel line from the outlet cap.** Route the fuel lines under the vehicle being sure to keep them away from heat and moving suspension components. Reinstall the fuel tank in the car by the manufacturers recommended procedure. **Note: It may be helpful in some instances to space the tank down slightly from the body to gain more clearance for the fuel hoses. A foam material with adhesive backing works well for this.**

CAUTION: While performing the following steps, if any fuel leaks are detected, immediately turn the fuel pump OFF, remove any spilled fuel and repair the leak(s) before proceeding!

29. Turn the fuel pump(s) ON **without starting the engine**, allow the pump to run for several seconds and check the fuel pressure. If there is no pressure, turn the fuel pump OFF, wait one minute, then turn the fuel pump ON and recheck the pressure. Repeat this fuel pump OFF and ON procedure until the fuel pressure gauge registers pressure or you detect a fuel leak. It may be necessary to loosen the fuel line fitting at the pressure regulator to bleed off excessive air in the system. Tighten any fuel line fittings which were loosened and ensure that any spilled fuel is cleaned up and removed from the vicinity of the vehicle. If no pressure is registered on the gauge after running the pump for several seconds and you have found no leaks, check all fuel and electrical connections to determine the cause.
30. Once the fuel pressure gauge registers pressure, start the engine. The gauge on the fuel pressure regulator should register between 35 and 60 psi. Adjust the fuel pressure regulator to the desired setting.
31. Test drive the vehicle to ensure proper operation and re-check the fuel system for leaks. **If any leaks are found, immediately discontinue use of the vehicle and repair the leak(s)!**

Contact Us

RGA NUMBER REQUIRED FOR ALL RETURNS TO AEROMOTIVE.

To obtain an RGA number, please call (913) 647-7300 and ask for the Returns and Repairs department or complete the online form under the "Rebuilds" section at www.aeromotiveinc.com.

- **Shipping & Returns**
Aeromotive Inc.
11414 W 79th Street.
Lenexa, KS 66214

General Inquiries and Tech Line: (913) 647-7300

General Email: info@aeromotiveinc.com

Tech Email: tech@aeromotiveinc.com

The Aeromotive Tech Lines are open Monday through Friday from 9:30AM to 5:00PM Central Standard Time.



WARNING: This product can expose you to chemicals, including chromium, which is known to the State of California to cause cancer or birth defects or other reproductive harm. For more information, visit: www.p65Warnings.ca.gov

AEROMOTIVE, INC. LIMITED WARRANTY

This Aeromotive Product, with proof of purchase dated on or after January 1, 2003, is warranted to be free from defects in materials and workmanship for a period of one year from the original date of purchase. No warranty claim will be valid without authentic, dated proof of purchase.

This warranty is to the original retail purchaser and none other and is available directly from Aeromotive and not through any point of distribution or purchase.

If a defect is suspected, the retail purchaser must contact Aeromotive directly to discuss the problem, possible solutions and obtain a Return Goods Authorization (RGA), if deemed necessary by the company. Please call 913-647-7300 and dial option 3 for the technical service dept. All returns must be shipped freight pre-paid to the company and with valid RGA before they will be processed.

Aeromotive will examine any product returned with the proper authorization to determine if the failure resulted from a defect or from abuse, improper installation, misapplication or alteration. Aeromotive will then, at it's sole discretion, return, repair or replace the product.

If any Aeromotive product is determined defective, buyer's exclusive remedy is limited in value to the sale price of the good. In no event shall Aeromotive be liable for incidental or consequential damages.

Aeromotive expressly retains the right to make changes and improvements in any product it manufactures and sells at any time. These changes and improvements may be made without notice at any time and without any obligation to change the catalogs or printed materials.

Aeromotive expressly retains the right to discontinue at any time and without notice any Aeromotive product that it manufactures or sells.

This warranty is limited and expressly limits any implied warranty to one year from the date of the original retail purchase on all Aeromotive products.

No person, party or corporate entity other than Aeromotive shall have the right to: determine whether or not this Limited Warranty is applicable to any Aeromotive product, authorize any action whatsoever under the terms and conditions of this Limited Warranty, assume any obligation or liability of any nature whatsoever on behalf of Aeromotive under the terms and conditions of this Limited Warranty.

This Limited Warranty covers only the product itself and not the cost of installation or removal.

This Limited Warranty is in lieu of and expressly excludes any and all other warranties, expressed or implied. This Limited Warranty gives you specific legal rights, and you may also have other rights which vary from state to state.