

Universal Small Block Chevy Carbureted Supercharger System Installation Instructions

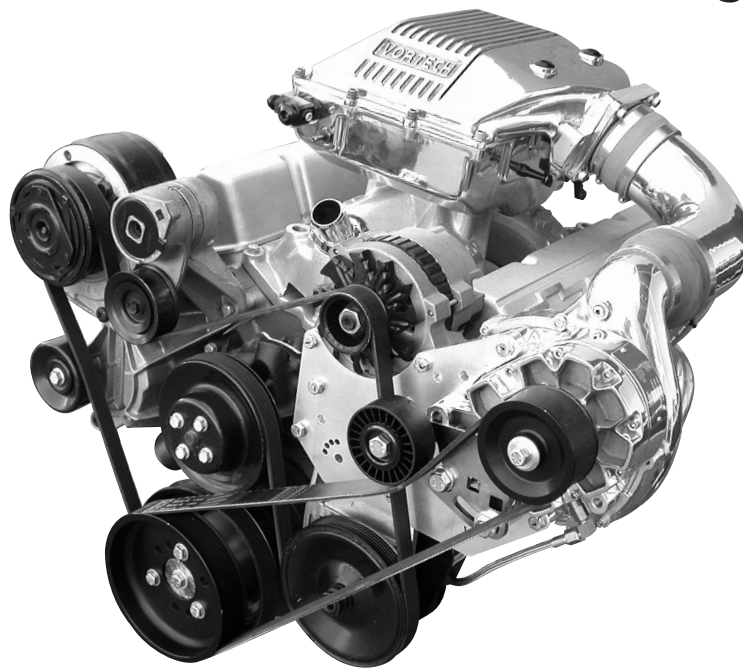

*Legal in California only for racing vehicles which may never be used upon a highway.



ENGINEERING, INC.

1650 Pacific Avenue, Channel Islands CA 93033-9901 • Phone: 805 247-0226
Fax: 805 247-0669 • www.vortechsuperchargers.com

FOREWORD

This manual provides information on the installation, maintenance and service of the Vortech supercharger kit expressly designed for this vehicle. All information, illustrations and specifications contained herein are based on the latest product information available at the time of this publication. Changes to the manual may be made at any time without notice. Contact Vortech Engineering for any additional information regarding this kit and any of these modifications at (805) 247-0226 7:00am-3:30pm PST.

Take note of the following before proceeding:

1. Proper installation of this supercharger kit requires general automotive mechanic knowledge and experience. Please browse through each step of this instruction manual prior to beginning the installation to determine if you should refer the job to a professional installer/technician. Please contact your dealer or Vortech Engineering for possible installers in your area.
2. This product was designed for use on stock (un-modified, OEM) vehicles. The PCM (computer), engine, transmission, drive axle ratios and tire O.D. must be stock. If the vehicle or engine has been modified in any way, check with Vortech prior to installation and use of this product.
3. Use only premium grade fuel with a minimum of 91 octane (*R+M/2*).
4. Always listen for any sign of detonation (*knocking/pinging*) and discontinue hard use (*no boost*) until problem is resolved.
5. Vortech is not responsible for any clutch, transmission, drive-line or engine damage.

Exclusions from Vortech warranty coverage considerations include, but not limited to:

1. Neglect, abuse, lack of maintenance, abnormal operation or improper installation.
2. Continued operation with an impaired vehicle or sub-system.
3. The combined use of Vortech components with other modifications such as, but not limited to, exhaust headers, aftermarket camshafts, nitrous oxide, third party PCM programming or other such changes.

©2017 VORTECH ENGINEERING, INC

All rights reserved. No part of this publication may be reproduced, transmitted, transcribed, or translated into another language in any form, by any means without written permission of Vortech Engineering, INC.

IMPORTANT PRE-INSTALLATION NOTES

Accessory Drive Notes:

- This system was designed to fit on engines equipped with a "long" water pump and OEM V-belt drives or serpentine accessory drives (OEM TPI/TBI applications, 1990-1995 and GM Performance Parts accessory drive system #'s 12497697, 12497698 and 12497869). For correct belt alignment, the proper accessory drive crank pulley and accessory bracketry must be used. These components are not supplied in this kit. Earlier models equipped with short water pumps will require a long water pump to be installed.
- This kit can be used on engines with and without power steering. For engines equipped with power steering and V-belt accessory drives, a Saginaw type pump will be required as well as an optional Vortech power steering pulley assembly 4GP110-051. This assembly includes all required hardware, tensioner assembly and anodized billet aluminum pulley. Depending on the vehicle, power steering lines may require fabrication.

The following carbureted system support parts are not included as part of the system but are available from Vortech.

Parts applicable to all carbureted system kits:

1. Compressor bypass valve and flange: (Contact the technical department to determine the proper valve selection for the application)
 - Vortech #8D204-001: Race Bypass Valve
 - Vortech #8D004-052: Race Bypass weld-on flange (aluminum)
 - Vortech #8D103-001: Mondo Bypass Valve
 - Vortech #8D003-052: Mondo Race Bypass weld-on flange (aluminum)
 - Vortech #8D205-003: BV57 Bypass Valve
 - Vortech #8D005-051: BV57 Bypass weld-on flange (aluminum)
2. Power steering pulley and hardware assembly as described above
 - Vortech #4GP110-051: Power Steering Pulley and Hardware Assembly

Parts applicable to "entry level" V3 Si-Trim kits only:

1. 10-rib belt upgrade kits (driven pulley diameter/crank pulley diameter)
 - Vortech #8E025-275: 10-Rib Upgrade, 2.75/6, SBC Entry Level
 - Vortech #8E025-295: 10-Rib Upgrade, 2.95/6, SBC Entry Level
 - Vortech #8E025-312: 10-Rib Upgrade, 3.12/6, SBC Entry Level

Parts applicable to non-entry level kits only:

1. Supercharger pulleys and retainer assembly: contact technical department for proper application match.
 - Vortech #2A031-250: Ø2.50", 10-rib driven pulley
 - Vortech #2A031-275: Ø2.75", 10-rib driven pulley
 - Vortech #2A031-295: Ø2.95", 10-rib driven pulley
 - Vortech #2A031-312: Ø3.12", 10-rib driven pulley
 - Vortech #4MA018-051: Ø7.00", 10-rib drive (crank) pulley
2. **REQUIRED, BUT NOT INCLUDED:** Custom fuel line/fitting kits for carburetor, stainless steel (designed specifically for Vortech carburetor enclosure)
 - Vortech #8M110-020: Holley 4150 series (w/dual metering blocks), SS fuel line kit
 - Vortech #8M110-030: Demon series, SS fuel line kit
3. Carburetor air diffuser. Straightens airflow into the carburetor for improved response/driveability
 - Vortech #8M011-001: Ø5.75" x 2.50" tall carburetor air-diffuser, stainless steel
4. Compressor bypass valve and flange:
 - Vortech #4GP012-031: Ø3" aluminum discharge duct w/attached flange for Vortech race bypass valve. Simple attachment to supplied silicone discharge elbow contained in #4GP218-030/-038

(this page intentionally left blank)

TABLE OF CONTENTS

FOREWORD	<i>ii</i>
TABLE OF CONTENTS	<i>v</i>
TOOL AND SUPPLY REQUIREMENTS	<i>vi</i>
PARTS LIST (<i>Universal Small Block Chevy Carbureted - V2 Si-Trim</i>)	<i>vii</i>
PARTS LIST (<i>Universal Small Block Chevy Carbureted - V1 T-Trim</i>)	<i>viii</i>
PARTS LIST (<i>Universal Small Block Chevy Carbureted - V7 YSi-Trim</i>)	<i>ix</i>
PARTS LIST (<i>Universal Small Block Chevy Carbureted - V3 Si-Trim</i>)	<i>x</i>
1. PREPARATION/REMOVAL	<i>1</i>
2. OIL FEED INSTALLATION (OIL-FED UNITS ONLY)	<i>1</i>
3. OIL DRAIN INSTALLATION (OIL-FED UNITS ONLY)	<i>2</i>
4.1 MAIN BRACKET/SUPERCHARGER INSTALLATION (<i>Serpentine</i>)	<i>3</i>
4.2 MAIN BRACKET/SUPERCHARGER INSTALLATION (<i>V-Belt</i>)	<i>4</i>
5. CRANK PULLEY AND SUPERCHARGER DRIVE PULLEY INSTALLATION	<i>6</i>
6.1 DISCHARGE DUCTING/CARBURETOR ENCLOSURE	<i>8</i>
6.2 DISCHARGE DUCTING/CARBURETOR HAT	<i>9</i>
7. FINAL REASSEMBLY AND CHECK	<i>10</i>

Universal Small Block Chevrolet Carbureted System

INSTALLATION INSTRUCTIONS

PLEASE READ CAREFULLY

This kit should only be installed by qualified mechanics. It is imperative that the correct air/fuel mixture be maintained at all times. This Universal Kit is to be supplied to competent engine tuners for their completion by the addition of, and tuning of, an appropriate carburetor unit and fuel pump.

This product is intended for use on healthy, well maintained engines. Installation on a worn-out or damaged engine is not recommended and may result in failure of the engine.

Vortech Engineering is not responsible for engine damage. Installation on new engines will not harm or adversely affect the break-in period so long as factory break-in procedures are followed.

1. Use only premium grade fuel 91 octane or higher (R+M/2).
2. The engine must have stock or lower than stock compression ratio.
3. If the engine has been modified in any way, check with Vortech prior to using this product.
4. Always listen for any sign of detonation (pinging) and discontinue hard use (no boost) until problem is resolved.
5. Perform an oil and filter change upon completion of this installation and prior to operating the vehicle. Thereafter, always use a high grade SF rated engine oil or a high quality synthetic, and change the oil and filter every 3000 miles.
6. Before beginning installation, replace all spark plugs with one to two step colder heat range and reset timing to no more than 26°-28° total. (Always follow the procedures indicated in the factory repair manual.)

TOOL AND SUPPLY REQUIREMENTS:

- Factory Repair Manual
- 3/8" Drive and Socket Set: SAE and Metric
- 1/2" Drive and Socket Set: SAE and Metric
- Adjustable Wrench
- Open End Wrenches: SAE and Metric
- Center Punch
- SF Rated Quality Engine Oil
- Loctite Sealer #RC-609
- Oil Filter, and Wrench
- Heavy Grease
- Silicone Sealer
- Teflon Paste Sealant
- TAP, 3/8-18 NPT





Universal Small Block Chevy Carbureted V2 Si-TRIM Part No. 4GP218-030SQ/038SQ PARTS LIST

IMPORTANT: Before beginning installation, verify that all parts are included in the kit. Report any shortages or damaged parts immediately.

PART NO.	DESCRIPTION	QTY	PART NO.	DESCRIPTION	QTY
2E128-040	S/C CHEV UNIV CARB, GEN2 V2	1	4GP111-041	ASY, MAN TENS. SBC GEN2	1
2A032-333	S/C DRIVE PLY, 3.33" 10-GRV	1	4MA116-160	IDLER ASY, MARINE GEN2	1
8R101-003	PULLEY RETAINER ASY, 10-RIB	1	4FA011-032	BELT TENSIONER PLATE STD	1
7U100-071	KEY, 3/16"SQ x 1-1/8" LONG	1	4GP017-051	SPACER, 10-RIB MAN TENS. SBC	1
2A040-011	PULLEY RETAINER S/C	1	7A437-300	7/16-14 x 3.00" SHCS GR8	1
7B375-150	3/8-24 x 1-1/2" GR8 HX	1	7C012-020	M12 x 1.75 x 20mm HXHD CL8.8	3
7K375-040	3/8"AN960 FLAT WASHER, PLATED	1	7J012-092	12mm WASHER, FLAT	3
8M001-060	CABLE, THROTTLE	1	7J438-072	7/16" WASHER, .94"OD x .109" THK	1
8M010-170	BRKT, CHVY THROTTLE CABLE	1	7J437-081	7/16"SAE WASHER PLATED	1
8M205-012	CARB ENCLOSURE ASY	1	4GB130-026	OIL FEED LINE ASY	1
007051	CARB ENCL ASY, UNIV SAT, G2 L	1	70000	INSPECTOR NUMBER	0
7A312-078	5/16-18 x 3/4" SHCS, S'STL	16	7P125-026	1/8"NPT x #4 SAE FLARE, 90°	1
7A312-253	STUD, 5/16" x 2-1/2" CARB ENCLOSURE	4	7P250-036	-4 SAE FLARE TO 1/4"NPT	1
7C011-050	10-32 PLUG SCREW	1	7P250-066	-4 45° FEM SWIVEL x 1/4"NPT	2
7F312-024	5/16-24 JAM NUT	4	7P250-080	1/4"NPT FEM. ELBOW, 90°	1
7J312-000	5/16" FLAT WASHER, SAE	4	7P250-123	1/4"NPT x 1-1/2" PIPE NIPPLE	1
7J375-024	3/8" COPPER WASHER	4	7P525-067	.525" CRIMP FERRULES	2
7K312-030	5/16"AN WASHER, SS	12	7U030-026	1/4" OIL FEED HOSE	3
7P187-102	-3 BULKHEAD FITTING TO 1/4" HOSE	1	7U100-055	TIE-WRAP, 7.5" NYLON	4
7P187-103	PLUG, -3 O-RING PORT	3	4GP130-036	OIL DRAIN ASY	1
7P250-120	1/4"NPT PIPE PLUG	1	7U030-036	1/2" OIL DRAIN HOSE	3
7P375-104	PLUG, 3/8-16, BRASS SHORT	4	7P375-017	3/8"NPT x 1/2" BEADED HOSE BARB	1
7PP500-087	PLUG, AN-8 O-RING PORT	3	7P375-033	3/8"NPT x 3/8"NPT SRT EL	2
7U100-003	O-RING 3 - 903	4	7R001-008	#8 STNLS HOSE CLAMP	2
7U100-008	O-RING 3 - 908	3	70000	INSPECTION NUMBER	0
7U100-020	10-32 GASKET	1	7T640-011	PUNCH, OIL PAN FTG	1
8M001-018	GASKET, 90mm THROTTLE BODY	1	4GP112-010	INLET ASY, S.B. CHEVY CARB.	1
8M003-051	MACH, MONDO COOLER COVER2	1	8H040-050	AIR FILTER 3.5" FLG. 7"L	1
8M010-025	MORSE CABLE BRKT, CARB ENC	1	4FA012-011	INTAKE TUBE, 180° w/o BOSSES	1
8M105-012	ENCL, STD. MACH ASY SAT.	1	7S350-200	SLEEVE, 3-1/2" x 2" BLUE	1
8M110-010	ASY, THROTTLE LINK, CARB ENCLOSURE	1	7R002-056	#56 SAE TYPE "F" SS HOSE CLAMP	3
8M001-017	HOLLEY 4-BARREL BASE GASKET	2	7R002-044	#44 SAE TYPE "F" SS HOSE CLAMP	1
4GP111-031	MTG BRKT ASY, SBC GEN2	1	75375-200	SLEEVE, Ø3.75" x 2.00"	1
4GP017-021	GM THROTTLE CABLE	1	75350-004	SLEEVE, Ø3.5" x 1"	1
4GP010-035	MOUNT PLATE, SBC UNIV. GEN2	1	7R002-060	#60 SAE TYPE "F" SS HOSE CLAMP	1
2A017-751-05	SPACER, .750"OD x .360" LONG	2	4GP112-040	DISCHARGE ASY, SBC GEN2 SAT	1
2A041-594	BELT, K100594-GATES	1	8M003-041	MACHINE, Ø3.5" FLANGE, SATIN	1
7A375-500	3/8-16 x 5" HXHD GRADE-8	2	7S350-276	ELBOW, SIL Ø3.5" x 2.75" CHEVY CARB	1
7A375-400	3/8-16 x 4" BOLT HXHD GR8	3	7R002-056	#56 SAE TYPE "F" SS HOSE CLAMP	1
7A375-100	3/8-16 x 1" G5 HHCS, PLT	5	7R002-044	#44 SAE TYPE "F" HOSE CLAMP	1
7A375-126	3/8-16 x 1.25" HHCS, GR8, PLT	4	4GP116-041	6" CRANK PLY ASY, SBC UNIV GEN2	1
4GB011-021	MOUNTING BRKT-MACH	1	4GP017-031	SPACER, SBC CRANK PULLEY, SERP	1
7K375-040	3/8"AN960 FLAT WASHER, PLATED	14	4MA018-041	6" CRANK PULLEY, UNIVERSAL	1
7A375-475	3/8-16 x 4.75" HXHD GR8 PLTD	2	7B375-500	3/8-24 x 5.0" HXHD GR8	3
7A375-375	3/8-16 x 3-3/4" HXHD	3	7B437-275	7/16-20 x 2.75" HXHD GR8	1
7A375-112	3/8-16 x 1.125" FLT HD ALN	2	7J375-044	3/8"SAE WASHER, PLTD	3
7A375-077	3/8-16 x 3/4" GR8 FLAT HD ZNC	1	7J438-081	7/16"SAE WASHER, PLATED	1
7C080-030	M8 x 1.25" x 30 HXHD CL10.9	1	4GP017-041	SPACER, SBC CRANK PULLEY, V-BELT	1
7C080-070	M8 x 1.25" x 70 HXHD ZINC	1	7B375-475	3/8-24 x 4-3/4" HXHD GR8	3
7F008-023	NUT, M8 x 1.25" x 70 HXHD ZINC	1	4GP020-015	INSTR. MANUAL, UNIV. SBC GEN2 KIT	1
7J008-001	3/8" FLAT WASHER	2	008443	S/C RACE INFO. PKG ASY, VORTECH	1
			008130	LICENSE PLATE FRAME, VORTECH	1
			008110	SMALL SILVER DIE-CUT DECAL	2



Universal Small Block Chevy Carbureted V1 T-Trim Part No. 4GP218-030T/038T PARTS LIST

IMPORTANT: Before beginning installation, verify that all parts are included in the kit. Report any shortages or damaged parts immediately.

PART NO.	DESCRIPTION	QTY	PART NO.	DESCRIPTION	QTY
2A138-040	S/C CHEV UNIV CARB, GEN2 V1	1	4GP111-041	ASY, MAN TENS. SBC GEN2	1
2A032-333	S/C DRIVE PLY, 3.33" 10-GRV	1	4MA116-160	IDLER ASY, MARINE GEN2	1
8R101-003	PULLEY RETAINER ASY, 10-RIB	1	4FA011-032	BELT TENSIONER PLATE STD	1
7U100-071	KEY, 3/16"SQ x 1-1/8" LONG	1	4GP017-051	SPACER, 10-RIB MAN TENS. SBC	1
2A040-011	PULLEY RETAINER S/C	1	7A437-300	7/16-14 x 3.00" SHCS GR8	1
7B375-150	3/8-24 x 1-1/2" GR8 HX	1	7C012-020	M12 x 1.75 x 20mm HXHD CL8.8	3
7K375-040	3/8"AN960 FLAT WASHER, PLATED	1	7J012-092	12mm WASHER, FLAT	3
8M001-060	CABLE, THROTTLE	1	7J438-072	7/16" WASHER, .94"OD x .109" THK	1
8M010-170	BRKT, CHVY THROTTLE CABLE	1	7J437-081	7/16"SAE WASHER PLATED	1
8M205-012	CARB ENCLOSURE ASY	1	4GB130-026	OIL FEED LINE ASY	1
007051	CARB ENCL ASY, UNIV SAT, G2 L	1	70000	INSPECTOR NUMBER	0
7A312-078	5/16-18 x 3/4" SHCS, S'STL	16	7P125-026	1/8"NPT x #4 SAE FLARE, 90°	1
7A312-253	STUD, 5/16" x 2-1/2" CARB ENCLOSURE	4	7P250-036	-4 SAE FLARE TO 1/4"NPT	1
7C011-050	10-32 PLUG SCREW	1	7P250-066	-4 45° FEM SWIVEL x 1/4"NPT	2
7F312-024	5/16-24 JAM NUT	4	7P250-080	1/4"NPT FEM. ELBOW, 90°	1
7J312-000	5/16" FLAT WASHER, SAE	4	7P250-123	1/4"NPT x 1-1/2" PIPE NIPPLE	1
7J375-024	3/8" COPPER WASHER	4	7P525-067	.525" CRIMP FERRULES	2
7K312-030	5/16"AN WASHER, SS	12	7U030-026	1/4" OIL FEED HOSE	3
7P187-102	-3 BULKHEAD FITTING TO 1/4" HOSE	1	7U100-055	TIE-WRAP, 7.5" NYLON	4
7P187-103	PLUG, -3 O-RING PORT	3	4GP130-036	OIL DRAIN ASY	1
7P250-120	1/4"NPT PIPE PLUG	1	7U030-036	1/2" OIL DRAIN HOSE	3
7P375-104	PLUG, 3/8-16, BRASS SHORT	4	7P375-017	3/8"NPT x 1/2" BEADED HOSE BARB	1
7PP500-087	PLUG, AN-8 O-RING PORT	3	7P375-033	3/8"NPT x 3/8"NPT SRT EL	2
7U100-003	O-RING 3 - 903	4	7R001-008	#8 STNLS HOSE CLAMP	2
7U100-008	O-RING 3 - 908	3	70000	INSPECTION NUMBER	0
7U100-020	10-32 GASKET	1	7T640-011	PUNCH, OIL PAN FTG	1
8M001-018	GASKET, 90mm THROTTLE BODY	1	4GP112-010	INLET ASY, S.B. CHEVY CARB.	1
8M003-051	MACH, MONDO COOLER COVER2	1	8H040-050	AIR FILTER 3.5" FLG. 7"L	1
8M010-025	MORSE CABLE BRKT, CARB ENC	1	4FA012-011	INTAKE TUBE, 180° w/o BOSSES	1
8M105-012	ENCL, STD. MACH ASY SAT.	1	7S350-200	SLEEVE, 3-1/2" x 2" BLUE	1
8M110-010	ASY, THROTTLE LINK, CARB ENCLOSURE	1	7R002-056	#56 SAE TYPE "F" SS HOSE CLAMP	3
8M001-017	HOLLEY 4-BARREL BASE GASKET	2	7R002-044	#44 SAE TYPE "F" SS HOSE CLAMP	1
4GP111-031	MTG BRKT ASY, SBC GEN2	1	75375-200	SLEEVE, Ø3.75" x 2.00"	1
4GP017-021	GM THROTTLE CABLE	1	75350-004	SLEEVE, Ø3.5" x 1"	1
4GP010-035	MOUNT PLATE, SBC UNIV, GEN2	1	7R002-060	#60 SAE TYPE "F" SS HOSE CLAMP	1
2A017-751-05	SPACER, .750"OD x .360" LONG	2	4GP112-040	DISCHARGE ASY, SBC GEN2 SAT	1
2A041-594	BELT, K100594-GATES	1	8M003-041	MACHINE, Ø3.5" FLANGE, SATIN	1
7A375-500	3/8-16 x 5" HXHD GRADE-8	2	7S350-276	ELBOW, SIL Ø3.5" x 2.75" CHEVY CARB	1
7A375-400	3/8-16 x 4" BOLT HXHD GR8	3	7R002-056	#56 SAE TYPE "F" SS HOSE CLAMP	1
7A375-100	3/8-16 x 1" G5 HHCS, PLT	5	7R002-044	#44 SAE TYPE "F" HOSE CLAMP	1
7A375-126	3/8-16 x 1.25" HHCS, GR8, PLT	4	4GP116-041	6" CRANK PLY ASY, SBC UNIV GEN2	1
4GB011-021	MOUNTING BRKT-MACH	1	4GP017-031	SPACER, SBC CRANK PULLEY, SERP	1
7K375-040	3/8"AN960 FLAT WASHER, PLATED	14	4MA018-041	6" CRANK PULLEY, UNIVERSAL	1
7A375-475	3/8-16 x 4.75" HXHD GR8 PLTD	2	7B375-500	3/8-24 x 5.0" HXHD GR8	3
7A375-375	3/8-16 x 3-3/4" HXHD	3	7B437-275	7/16-20 x 2.75" HXHD GR8	1
7A375-112	3/8-16 x 1.125" FLT HD ALN	2	7J375-044	3/8"SAE WASHER, PLTD	3
7A375-077	3/8-16 x 3/4" GR8 FLAT HD ZNC	1	7J438-081	7/16"SAE WASHER, PLATED	1
7C080-030	M8 x 1.25" x 30 HXHD CL10.9	1	4GP017-041	SPACER, SBC CRANK PULLEY, V-BELT	1
7C080-070	M8 x 1.25" x 70 HXHD ZINC	1	7B375-475	3/8-24 x 4-3/4" HXHD GR8	3
7F008-023	NUT, M8 x 1.25" x 70 HXHD ZINC	1	4GP020-015	INSTR. MANUAL, UNIV. SBC GEN2 KIT	1
7J008-001	3/8" FLAT WASHER	2	008443	S/C RACE INFO. PKG ASY, VORTECH	1
			008130	LICENSE PLATE FRAME, VORTECH	1
			008110	SMALL SILVER DIE-CUT DECAL	2



Universal Small Block Chevy Carbureted V7 YSI-Trim Part No. 4GP218-030YSI/038YSI PARTS LIST

IMPORTANT: Before beginning installation, verify that all parts are included in the kit. Report any shortages or damaged parts immediately.

PART NO.	DESCRIPTION	QTY	PART NO.	DESCRIPTION	QTY
2A158-070	S/C CHEV UNIV CARB, GEN2 V7	1	4GP111-041	ASY, MAN TENS. SBC GEN2	1
2A032-333	S/C DRIVE PLY, 3.33" 10-GRV	1	4MA116-160	IDLER ASY, MARINE GEN2	1
8R101-003	PULLEY RETAINER ASY, 10-RIB	1	4FA011-032	BELT TENSIONER PLATE STD	1
7U100-071	KEY, 3/16"SQ x 1-1/8" LONG	1	4GP017-051	SPACER, 10-RIB MAN TENS. SBC	1
2A040-011	PULLEY RETAINER S/C	1	7A437-300	7/16-14 x 3.00" SHCS GR8	1
7B375-150	3/8-24 x 1-1/2" GR8 HX	1	7C012-020	M12 x 1.75 x 20mm HXHD CL8.8	3
7K375-040	3/8"AN960 FLAT WASHER, PLATED	1	7J012-092	12mm WASHER, FLAT	3
8M001-060	CABLE, THROTTLE	1	7J438-072	7/16" WASHER, .94"OD x .109" THK	1
8M010-170	BRKT, CHVY THROTTLE CABLE	1	7J437-081	7/16"SAE WASHER PLATED	1
8M205-012	CARB ENCLOSURE ASY	1	4GB130-026	OIL FEED LINE ASY	1
007051	CARB ENCL ASY, UNIV SAT, G2 L	1	70000	INSPECTOR NUMBER	0
7A312-078	5/16-18 x 3/4" SHCS, S'STL	16	7P125-026	1/8"NPT x #4 SAE FLARE, 90°	1
7A312-253	STUD, 5/16" x 2-1/2" CARB ENCLOSURE	4	7P250-036	-4 SAE FLARE TO 1/4"NPT	1
7C011-050	10-32 PLUG SCREW	1	7P250-066	-4 45° FEM SWIVEL x 1/4"NPT	2
7F312-024	5/16-24 JAM NUT	4	7P250-080	1/4"NPT FEM. ELBOW, 90°	1
7J312-000	5/16" FLAT WASHER, SAE	4	7P250-123	1/4"NPT x 1-1/2" PIPE NIPPLE	1
7J375-024	3/8" COPPER WASHER	4	7P525-067	.525" CRIMP FERRULES	2
7K312-030	5/16"AN WASHER, SS	12	7U030-026	1/4" OIL FEED HOSE	3
7P187-102	-3 BULKHEAD FITTING TO 1/4" HOSE	1	7U100-055	TIE-WRAP, 7.5" NYLON	4
7P187-103	PLUG, -3 O-RING PORT	3	4GP130-036	OIL DRAIN ASY	1
7P250-120	1/4"NPT PIPE PLUG	1	7U030-036	1/2" OIL DRAIN HOSE	3
7P375-104	PLUG, 3/8-16, BRASS SHORT	4	7P375-017	3/8"NPT x 1/2" BEADED HOSE BARB	1
7PP500-087	PLUG, AN-8 O-RING PORT	3	7P375-033	3/8"NPT x 3/8"NPT SRT EL	2
7U100-003	O-RING 3 - 903	4	7R001-008	#8 STNLS HOSE CLAMP	2
7U100-008	O-RING 3 - 908	3	70000	INSPECTION NUMBER	0
7U100-020	10-32 GASKET	1	7T640-011	PUNCH, OIL PAN FTG	1
8M001-018	GASKET, 90mm THROTTLE BODY	1	4GP112-010	INLET ASY, S.B. CHEVY CARB.	1
8M003-051	MACH, MONDO COOLER COVER2	1	8H040-050	AIR FILTER 3.5" FLG. 7"L	1
8M010-025	MORSE CABLE BRKT, CARB ENC	1	4FA012-011	INTAKE TUBE, 180° w/o BOSSES	1
8M105-012	ENCL, STD. MACH ASY SAT.	1	7S350-200	SLEEVE, 3-1/2" x 2" BLUE	1
8M110-010	ASY, THROTTLE LINK, CARB ENCLOSURE	1	7R002-056	#56 SAE TYPE "F" SS HOSE CLAMP	3
8M001-017	HOLLEY 4-BARREL BASE GASKET	2	7R002-044	#44 SAE TYPE "F" SS HOSE CLAMP	1
4GP111-031	MTG BRKT ASY, SBC GEN2	1	75375-200	SLEEVE, Ø3.75" x 2.00"	1
4GP017-021	GM THROTTLE CABLE	1	75350-004	SLEEVE, Ø3.5" x 1"	1
4GP010-035	MOUNT PLATE, SBC UNIV, GEN2	1	7R002-060	#60 SAE TYPE "F" SS HOSE CLAMP	1
2A017-751-05	SPACER, .750"OD x .360" LONG	2	4GP112-040	DISCHARGE ASY, SBC GEN2 SAT	1
2A041-594	BELT, K100594-GATES	1	8M003-041	MACHINE, Ø3.5" FLANGE, SATIN	1
7A375-500	3/8-16 x 5" HXHD GRADE-8	2	7S350-276	ELBOW, SIL Ø3.5" x 2.75" CHEVY CARB	1
7A375-400	3/8-16 x 4" BOLT HXHD GR8	3	7R002-056	#56 SAE TYPE "F" SS HOSE CLAMP	1
7A375-100	3/8-16 x 1" G5 HHCS, PLT	5	7R002-044	#44 SAE TYPE "F" HOSE CLAMP	1
7A375-126	3/8-16 x 1.25" HHCS, GR8, PLT	4	4GP116-041	6" CRANK PLY ASY, SBC UNIV GEN2	1
4GB011-021	MOUNTING BRKT-MACH	1	4GP017-031	SPACER, SBC CRANK PULLEY, SERP	1
7K375-040	3/8"AN960 FLAT WASHER, PLATED	14	4MA018-041	6" CRANK PULLEY, UNIVERSAL	1
7A375-475	3/8-16 x 4.75" HXHD GR8 PLTD	2	7B375-500	3/8-24 x 5.0" HXHD GR8	3
7A375-375	3/8-16 x 3-3/4" HXHD	3	7B437-275	7/16-20 x 2.75" HXHD GR8	1
7A375-112	3/8-16 x 1.125" FLT HD ALN	2	7J375-044	3/8"SAE WASHER, PLTD	3
7A375-077	3/8-16 x 3/4" GR8 FLAT HD ZNC	1	7J438-081	7/16"SAE WASHER, PLATED	1
7C080-030	M8 x 1.25" x 30 HXHD CL10.9	1	4GP017-041	SPACER, SBC CRANK PULLEY, V-BELT	1
7C080-070	M8 x 1.25" x 70 HXHD ZINC	1	7B375-475	3/8-24 x 4-3/4" HXHD GR8	3
7F008-023	NUT, M8 x 1.25" x 70 HXHD ZINC	1	4GP020-015	INSTR. MANUAL, UNIV. SBC GEN2 KIT	1
7J008-001	3/8" FLAT WASHER	2	008443	S/C RACE INFO. PKG ASY, VORTECH	1
			008130	LICENSE PLATE FRAME, VORTECH	1
			008110	SMALL SILVER DIE-CUT DECAL	2
			7S400-350	REDUCER, 4" - 3.5"	1
			7R002-064	#64 SAE TYPE "F" SS HOSE CLAMP	1



Universal Small Block Chevy Carbureted V3 Si-Trim Entry Level Kit

Part No. 4GP218-050L/058L

PARTS LIST

IMPORTANT: Before beginning installation, verify that all parts are included in the kit. Report any shortages or damaged parts immediately.

PART NO.	DESCRIPTION	QTY	PART NO.	DESCRIPTION	QTY
008118	DECAL, VINYL, VORTECH	1	4GP116-051	CRK PLY ASY, SBC UNIV ENTRY	1
008130	LICENSE PLATE FRAME, VORTECH	1	4GP017-031	SPACER, SBC CRANK PULLEY, SERP	1
008445	1 YR S/C STRT INFOR PKG ASY VORTECH	1	4GP017-041	SPACER, SBC CRANK PULLEY, V-BELT	1
009035	S/C LUBE, BOTTLED, VORT 3-PACK	1	4MA018-031	CRANK PLY, 6-RIB, 6", UNIV	1
2A046-580	BELT, 4060580 GOODYEAR	1	7B375-475	3/8-24 x 4-3/4" HXHD GR8	3
2F328-070	V3 S/C ASY, SBC ENTRY LVL, SAT, 3.33 PLY	1	7B375-500	3/8-24 x 5.0" HXHD GR8	3
4FA111-032	S/C BELT TENSNR ASY, 6 RIB	1	7B437-275	7/16-20 x 2.75" HXHD GR8	1
2A017-010	SPACER, IDLER PULY, 5.0 6 RIB	1	7J375-044	3/8"SAE WASHER, PLTD	3
4FA011-042	BELT TENS PLATE, HEAVY DUTY	1	7J438-081	7/16"SAE WASHER, PLATED	1
4FA016-150	IDLER PULY, 6RIB 3 5" FLANGED	1	8H040-050	AIR FILTER 3 5"FLG X 7"L	1
7C012-020	M12 X 1 75 X 20MM HXHD CL8 8	2	8M106-011	ASSY, CARB HAT	1
7C012-022	M12 X 1 75 X 20MM THIN HD	1	2H100-040	RETAINER, CARB HAT	10
7C012-050	M12 X 1 75 X 50MM HXHD BOLT	1	7A250-051	1/4-20 X 50 HHCS GR5 ZINC PLT	10
7G010-175	12MM X 1 75 NUT	1	7A312-276	5/16-18 X 2 75 SHCS GR8 ZINC	1
7J012-092	12MM WASHER, FLAT	1	7J312-010	5/16" GASKET SEALING WASHER	1
4GP020-015	INSTR MAN, UNIV SBC GEN 2 KIT	1	8M001-025	GASKET, CARB BONNET BASE	1
4GP111-031	MTG BRKT ASY, SBC GEN2	1	8M006-011	HSG, MACH, CARB HAT	1
2A017-751-05	SPACER, .750"OD x .360" LONG	2	8M006-031	BASE, MACH, CARB HAT	1
4GB011-021	MOUNTING BRKT-MACH	1	8M011-020	DIFFUSER, CARB HAT, 8.25 OD	1
4GP010-035	MOUNT PLATE, SBC UNIV, GEN2	1			
4GP017-021	SPACER, HEAD, SBC 360 THK	1			
7A375-077	3/8-16 x 3/4" GR8 FLAT HD ZNC	1			
7A375-100	3/8-16 x 1" G5 HHCS, PLT	5			
7A375-102	3/8-16 X 1" FHCS, ZINC, PLT	3			
7A375-123	3/8-16 X 1 25" FLT HD ALN	2			
7A375-126	3/8-16 X 1 25 HHCS, GR8, PLT	4			
7A375-375	3/8-16 x 3-3/4" HXHD	3			
7A375-400	3/8-16 x 4" BOLT HXHD GR8	3			
7A375-475	3/8-16 x 4.75" HXHD GR8 PLTD	2			
7A375-500	3/8-16 x 5" HXHD GRADE-8	2			
7C080-030	M8 x 1.25" x 30 HXHD CL10.9	1			
7C080-070	M8 x 1.25" x 70 HXHD ZINC	1			
7F008-023	NUT, M8 x 1.25" x 70 HXHD ZINC	1			
7J008-001	3/8" FLAT WASHER	2			
7K375-040	3/8"AN960 FLAT WASHER, PLATED	14			
4GP112-050	ASSY, DISCH, SBC ENTRY LVL	1			
4GP012-050	DISCH TUBE, SBC ENTRY LVL, TUMBLED	1			
7PS275-200	SLEEVE, BLACK 2 75ID X 2 0	1			
7PS300-275	REDUCER, BLK Ø3 0-Ø2 75	1			
7R002-044	#44 SAE TYPE "F" HOSE CLAMP	3			
7R002-048	#48 SAE TYPE F SS HOSE CLAMP	1			

1. PREPARATION/REMOVAL

- A. Disconnect the negative lead to the battery.
- B. Remove the fan and shroud to aid in installation. It may also be necessary to install a fan spacer at a later time.
- C. **(V-Belt Equipped Applications)**
 - 1. Loosen all nuts and bolts that are used to tension the alternator and power steering pump V-belts. Remove the factory belts.
 - 2. Remove the factory power steering pump from the engine.
- D. **(Serpentine-Belt Equipped Applications)**
 - 1. Loosen tension on the tensioner and remove the factory drive belt.
 - 2. If so equipped, loosen the two

screws securing the alternator to the cast factory bracket on the driver's side. Disconnect any other electrical connections to the alternator. Remove the alternator from the bracket and set aside.

- 3. Remove the power steering pulley from the power steering pump. Loosen the screws securing the pump and remove the pump from the factory bracket. Temporarily lay the pump in the engine compartment.
- 4. Remove the factory cast bracket from the driver's side of the engine.

V-BELT APPLICATION NOTE: This kit is designed to work with later model V-belt power steering pumps. The power steering pulley shaft should be $\text{\O}3/4"$ and will not be threaded at the end.

2. OIL FEED INSTALLATION (OIL-FED UNITS ONLY)

- A. The supercharger uses engine oil for lubrication and must have an oil feed line connected to a filtered oil access point on the engine.
- B. Remove the 1/4"NPT plug located on the engine block just above the oil filter boss. Replace the plug with the supplied 1/4"NPT x 90° elbow and 1/4"NPT x -4 flare fitting.

NOTE: Use clean engine oil on the pipe threads. Teflon tape and sealant is not recommended as it might loosen and cause blockage of the small oil feed orifice resulting in supercharger failure.

- C. Connect the supplied feed line to the flare fitting and route it up to the front of the driver side cylinder head. Secure the hose with tie-wraps away from exhaust heat, chafing and/or sharp objects. Temporarily cover the open end from debris until the connection is made to the supercharger. (See Fig. 2-a.)

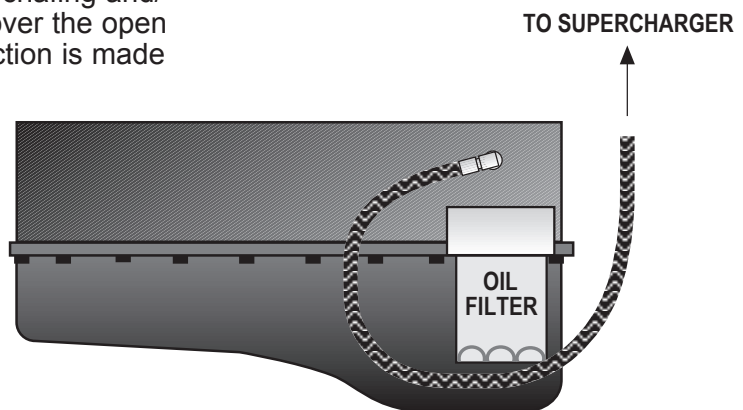

Fig. 2-a

3. OIL DRAIN INSTALLATION (OIL-FED UNITS ONLY)

- A. To provide an oil drain for the supercharger, it is necessary to make a hole in the oil pan. Locate and mark the hole location. (See Fig. 3-a.) It is best to punch the hole rather than drill.

NOTE: Removal of the oil pan may ease oil drain fitting installation on some applications.

- B. Remove any paint from around the hole area.
- C. Use a small center punch to perforate the pan and expand the hole, switch to a larger diameter punch and expand the hole further to approximately $\text{Ø}9/16"$. Most punches are made from hexagon material and may be placed in a socket with an extension to make this procedure easier. Use caution so that the hole is not enlarged too much and that the punch does *NOT* contact the crankshaft.
- D. Tap the hole with a 3/8"NPT tap approximately 1/4" deep. Pack the flutes of the tap with heavy grease to hold the chips. Use a small magnet to check for any stray chips.

NOTE: This method of rolling over the lip of the hole and tapping works well if carefully done and should cause no problems.

- E. Thoroughly clean the threaded area. Apply a small amount of silicone sealer to the new threads. Apply more sealer to the supplied 3/8"NPT x 90° elbow and secure in the previously threaded hole. Make sure a seal is formed all around the fitting. Rotate the fitting so that the oil drain hose can be easily routed to it. Apply sealer to the supplied 3/8"NPT x 1/2" beaded hose barb fitting and install in the previously installed 90° elbow.
- F. Drain the engine oil, install a new filter and refill with fresh oil.

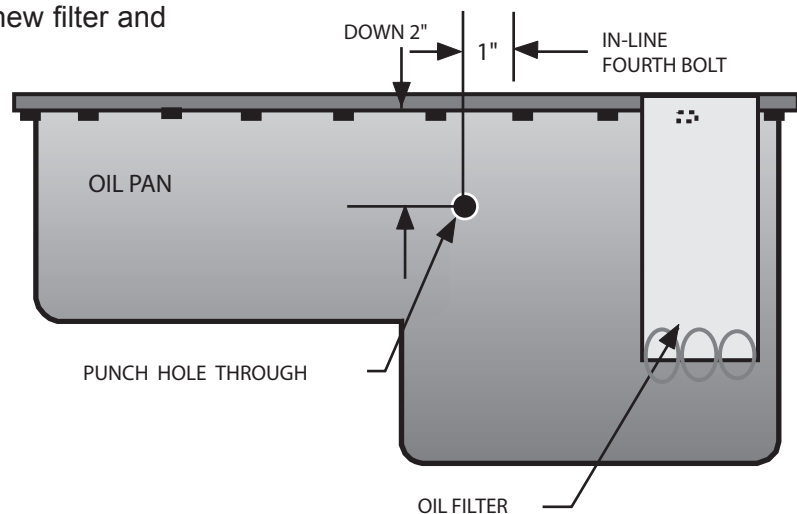

Fig. 3-a

4.1 MAIN BRACKET/SUPERCHARGER INSTALLATION (Serpentine)

NOTE: Some applications (depending on intake manifold height) may require the relocking of the supercharger volute. If relocking is required for your application, loosen and remove the six 1/4-20 cap screws and retaining plates that hold the compressor housing (volute) to the gearcase. If the compressor housing does not rotate freely relative to the gearcase, DO NOT FORCE IT. SERIOUS SUPERCHARGER DAMAGE MAY OCCUR. The machined mating surfaces are designed to prevent pressurized air from escaping and have minimal tolerances. If the housing will not move or is very tight, contact Vortech Engineering immediately at 805 247-0226 and ask our service department for further assistance.

- A. Locate the supplied cast bracket, L-shaped spacer, and two .360" thick spacers.
- B. Use the 3/8-16 x 4" screws and washers to mount the cast bracket to the cylinder head using the .360" L-shaped spacer between the bracket and cylinder head. Use the 3/8-16 x 5" hardware to mount the lower section of the cast bracket to the block with the two .360" spacers. (See Fig. 4.1-a.)
- C. **Single Plate Applications Only:** Locate the supplied supercharger mounting plate. Secure the plate to the mounting bracket with the supplied 3/8-16 x 1.25" screws and washers. (See Fig. 4.1-b.)

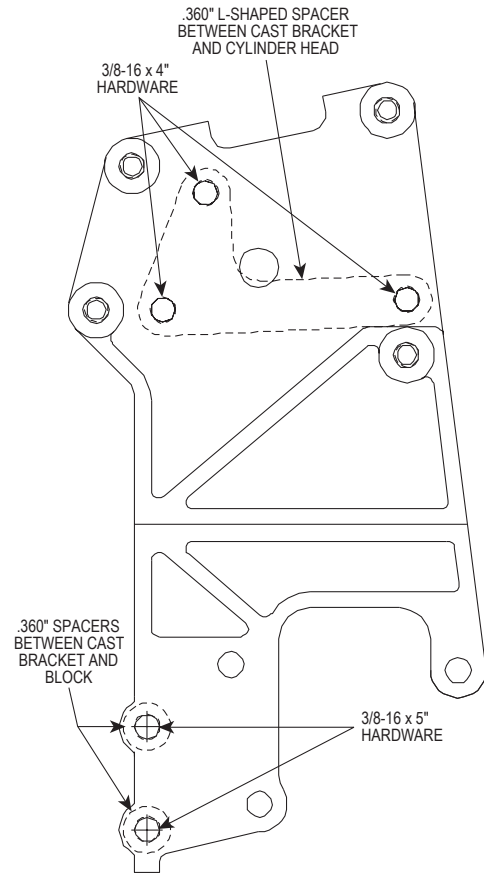
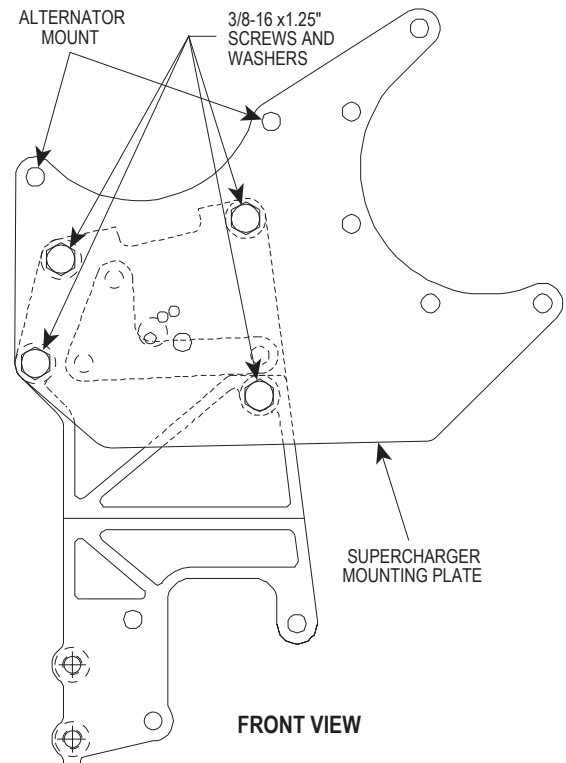

Fig. 4.1-a



FRONT VIEW

Fig. 4.1-b

4.1 MAIN BRACKET/SUPERCHARGER INSTALLATION (Serpentine), cont'd

D. Dual-Plate Applications Only:

1. Locate the supplied steel supercharger mounting plate. Attach the plate to the cast aluminum mounting bracket with the two supplied 3/8-16 x 1" screws in the locations shown in *Fig 4.1-c*. Do not tighten the screws at this time. They will be removed in a future step. Leave finger tight.
2. Place the supercharger into position on the steel supercharger mounting plate. Lightly "snug" the two supplied 3/8-16 x 1" screws (with washers) into the supercharger at the locations shown in *Fig 4.1-c*. Do not tighten the screws at this time. Leave finger tight.
3. Locate the supplied aluminum supercharger mounting plate. Loosely attach the plate to the supercharger and bracket assembly using five of the supplied 3/8-16 x 2.75" screws (with washers) and 1.434" long spacers. Sandwich the spacers between the two mounting plates.
4. Remove the two 3/8-16 x 1" screws that were temporarily installed into the bracket in a previous step. Attach the two remaining sets of 3/8-16 x 2.75" screws (with washers) and 1.434" long spacers. Tighten all hardware. (See *Fig. 4.1-d*).

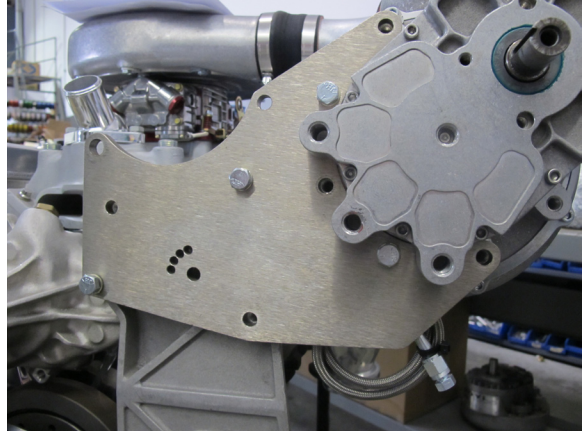

4.1-c

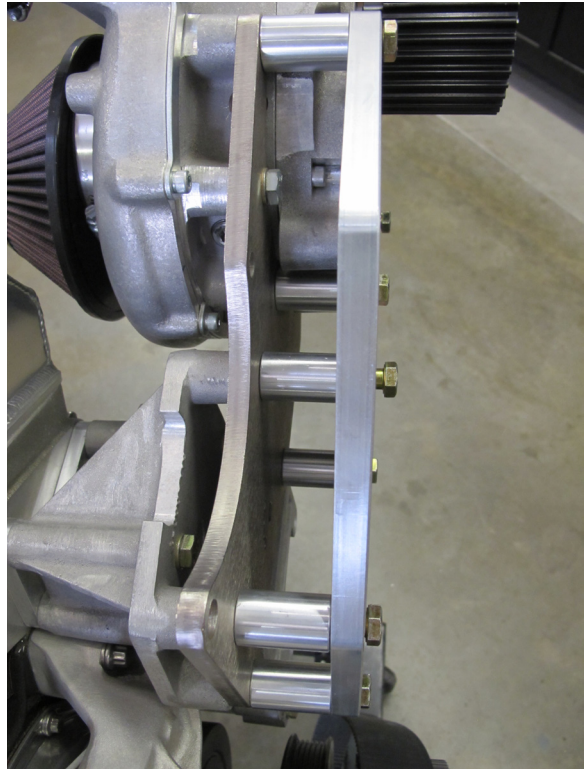

4.1-d

4.1 MAIN BRACKET/SUPERCHARGER INSTALLATION (Serpentine), cont'd

5. Locate the supplied idler hardware and idler shown in *Figs. 4.1-e, 4.1-f, and 4.1-g*. Apply a small amount of anti-seize lube to the threads of the idler adjustment screw (3/8-16 threads). Attach the idler and hardware as shown. Do not tighten the hardware until the belt is fitted and installed in a future step.



4.1-e



4.1-f

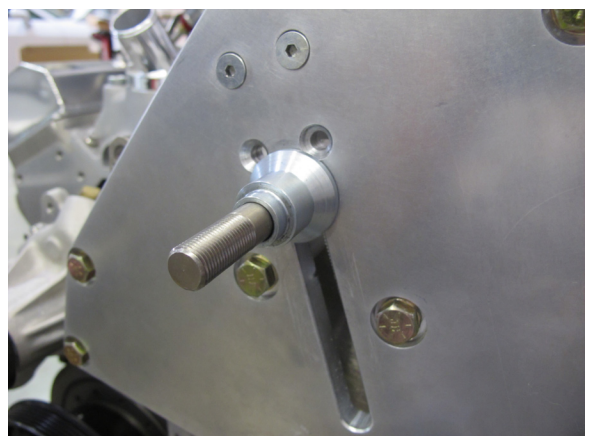

4.1-g

4.1 MAIN BRACKET/SUPERCHARGER INSTALLATION (Serpentine), cont'd

- E. Mount the power steering pump (if equipped) to the back side of the cast bracket using the supplied 3/8-16 flat-head screws. Reinstall the power steering pulley. (See Figs. 4.2-b, 4.2-c.)
- F. Mount the alternator to the mounting plate with the supplied 8mm hardware. (See Fig. 4.1-h.)
- G. **Oil-Fed Applications Only:**
Attach the oil drain hose to the 1/2" barbed fitting on the bottom of the supercharger. Secure the hose with the supplied hose clamp.
- H. **Single Plate Applications Only:**
Using the supplied 3/8-16 x 1.0" screws and washers, secure the supercharger to the mounting plate. (See Fig. 4.2-c.)



Fig. 4.1-h

4.2 MAIN BRACKET/SUPERCHARGER INSTALLATION (V-Belt)

- A. Locate the supplied cast bracket. (See Fig. 4.2-a.)

NOTE: Due to the many possible configurations of accessory drives in Small Block Chevy applications, the accessory drive crank pulley spacer may be modified to mate with the supplied supercharger drive crank pulley and the vehicle's existing accessory drive crank pulley.

- B. **(Non-power steering only, P/S models proceed to 4.2-C.)** Using the 3/8-16 x 3.75" screws and washers, mount the cast bracket to the cylinder head. Use the 3/8-16 x 4.75" screws and washers to secure the lower section of the cast bracket to the engine block.
- C. **(Power steering models only.)** Locate the optional 4GP110-051 P/S pump support assembly. Using the 3/8-16 x 3.75" screws and washers, mount the cast bracket to the cylinder head. Install the 3/8-16 x 6.75" screws and washers through the power steering tensioner bracket, .915" long spacers, cast bracket, and into the engine block. (See Fig. 4.2-a.)
 1. Locate the supplied P/S belt tensioner pulley. Install the 3/8-16 x 1.75" screw and washer through the tensioner bracket. Place the pulley/pilot assembly onto the previously installed 3/8-16 x 1.75" screw and loosely secure using the 3/8" washer and lock nut.

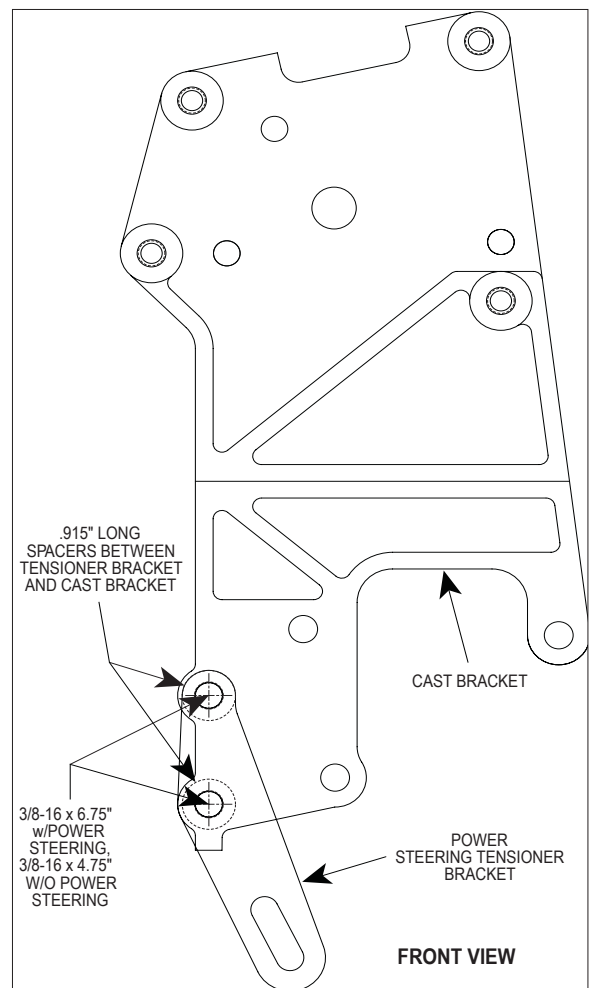

Fig. 4.2-a
(Power Steering Equipped Models Only)

4.2 MAIN BRACKET/SUPERCHARGER INSTALLATION (V-Belt), cont'd

2. Mount the power steering pump to the back side of the cast bracket using the supplied 3/8-16 flat-head screws. Locate the power steering pump drive flange. Using the appropriate GM power steering pulley installer, install the drive flange as you would a normal power steering pulley. (See Fig. 4.2-b.)
3. Using the six 1/4-20 x .75" screws and washers, attach the supplied power steering pulley. (Blue loc-tite on the threads is recommended.) (See Figs. 4.2-b, 4.2-c.)

NOTE: The end of the pump shaft should be flush with the end of the drive flange when fully installed.

- D. Single Plate Applications Only:**
Locate the supplied supercharger mounting plate. Secure the plate to the mounting bracket with the supplied 3/8-16 x 1.25" screws and washers. (See Fig. 4.1-b on previous page.)

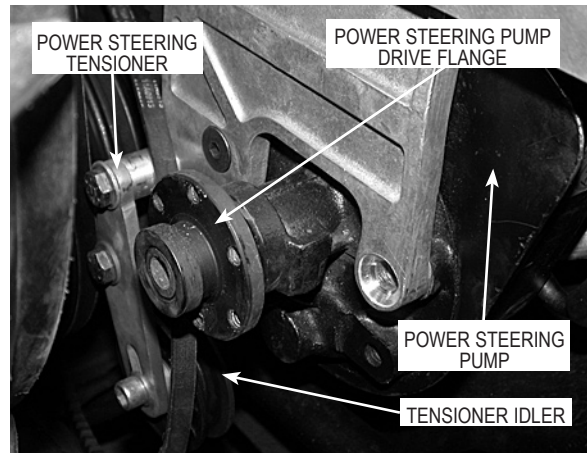

Fig. 4.2-b
(Power Steering Equipped Models Only)

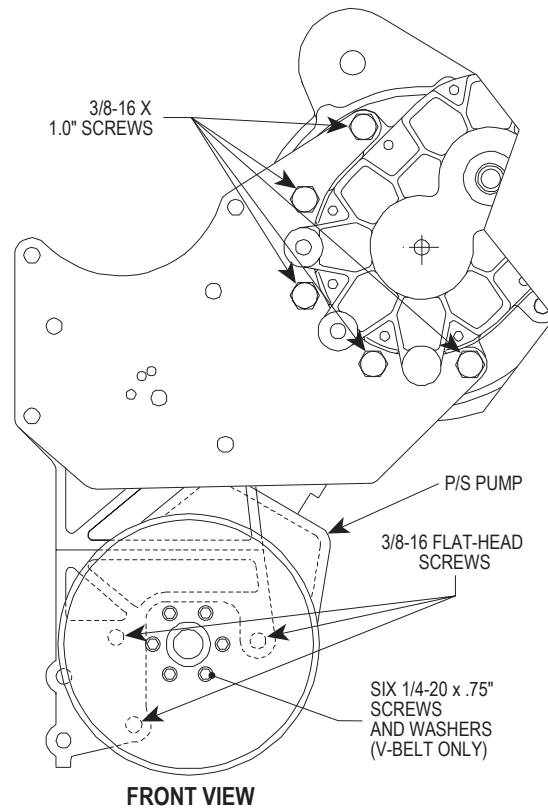
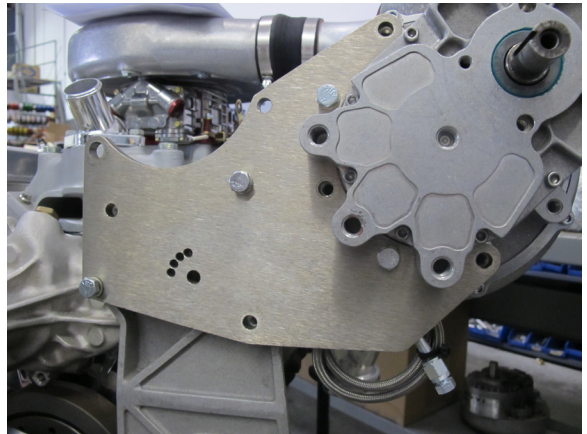

Fig. 4.2-c

E. Dual-Plate Applications Only:

1. Locate the supplied steel supercharger mounting plate. Attach the plate to the cast aluminum mounting bracket with the two supplied 3/8-16 x 1" screws in the locations shown in *Fig 4.2-d*. Do not tighten the screws at this time. They will be removed in a future step. Leave finger tight.
2. Place the supercharger into position on the steel supercharger mounting plate. Lightly "snug" the two supplied 3/8-16 x 1" screws (with washers) into the supercharger at the locations shown in *Fig 4.2-d*. Do not tighten the screws at this time. Leave finger tight.
3. Locate the supplied aluminum supercharger mounting plate. Loosely attach the plate to the supercharger and bracket assembly using five of the supplied 3/8-16 x 2.75" screws (with washers) and 1.434" long spacers. Sandwich the spacers between the two mounting plates.
4. Remove the two 3/8-16 x 1" screws that were temporarily installed into the bracket in a previous step. Attach the two remaining sets of 3/8-16 x 2.75" screws (with washers) and 1.434" long spacers. Tighten all hardware. (See *Fig. 4.2-e*).



4.2-d

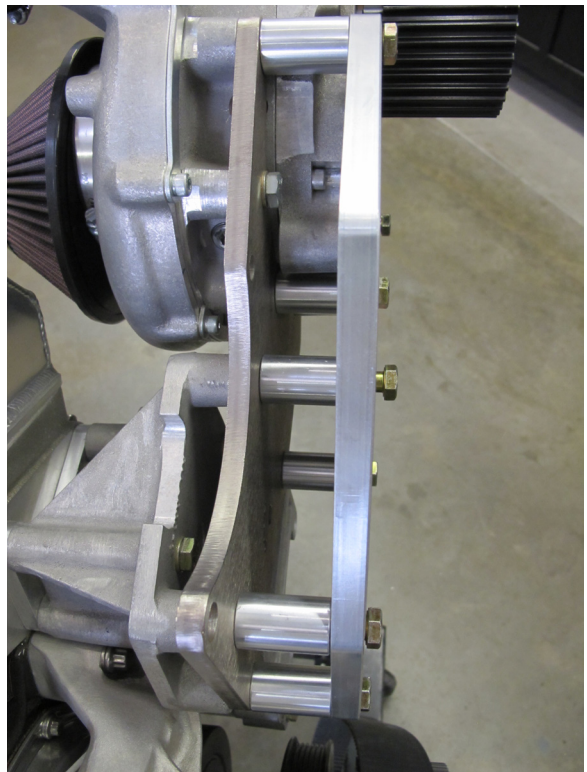

4.2-e

5. Locate the supplied idler hardware and idler shown in *Figs. 4.2-f, 4.2-g, and 4.2-h*. Apply a small amount of anti-seize lube to the threads of the idler adjustment screw (3/8-16 threads). Attach the idler and hardware as shown. Do not tighten the hardware until the belt is fitted and installed in a future step.

F. Oil-Fed Applications Only:

Attach the oil drain hose to the 1/2" barbed fitting on the bottom of the supercharger. Secure the hose with the supplied hose clamp.

G. Single Plate Applications Only:

Using the supplied 3/8-16 x 1.0" screws and washers secure the supercharger to the mounting plate. (See *Fig. 4.2-c*.)



4.2-f



4.2-g

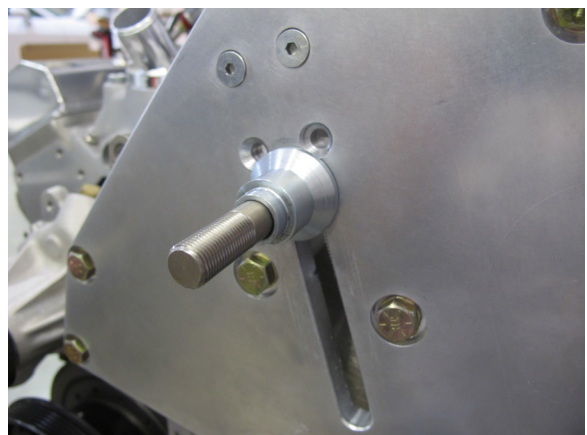

4.2-h

5. CRANK PULLEY AND SUPERCHARGER DRIVE PULLEY INSTALLATION

NOTE: Two crank pulley spacers are provided in this system. 4GP017-031 (3.695" long) is to be used for serpentine drive systems. The 4GP017-041 (3.293" long) is to be used for V-belt applications.

- A. Locate the supercharger drive assembly (4GP116-041). Using the 7/16-20 x 2.75" screw and washer, loosely install the appropriate spacer for your application to the front of the factory crank pulley.
- B. Rotate the previously installed crank pulley spacer to align the three mounting holes. Install the supplied supercharger crank pulley and secure using the supplied hardware. (3/8-24 x 5" for Serpentine and 3/8-24 x 4.75" for V-belt applications.) Torque center bolt to 35 ft.lbs. and the three pulley retainers to 25 ft.lbs.

NOTE: Take care to ensure that all pulleys and spacer are piloting correctly and seated flat against their mounting faces.

- C. Install all applicable accessory belts at this time and tension using the appropriate belt tensioner for your application.
- D. **(10-Rib Units Only)** Lightly grease the supercharger input shaft and/or the supercharger drive pulley bore. Install the pulley onto the supercharger input shaft and rotate the pulley to align the keyways. Slide the square key into the keyway. Install the pulley retainer assembly into the input shaft and hand tighten.

NOTE: If the supercharger drive pulley will not slide onto the shaft DO NOT FORCE IT. Light heating of the supercharger drive pulley with a propane torch will aid in installation.

- E. Locate the manual tensioner assembly:
 1. **10-Rib Applications (4GP111-041):** Install the 7/16-20 screw through the 7/16" "thick" washer, tensioner pulley, pulley spacer and tensioner plate. Secure using the 7/16"SAE washer (thinner one) and Nyloc nut provided.

NOTE: The bearing retaining ring on the pulley should be facing the pulley spacer to properly clear the "thick" retaining washer. (See Fig. 6-d.)

2. **6-Rib Applications (4FA111-032):** Install the M12 x 50mm screw through the steel dust shield, tensioner pulley, large diameter pulley spacer, small pulley spacer, and then through the tensioner plate. Secure the assembly using the M12 nut.

- F. Loosely install the belt tensioner assembly onto the supercharger using the M12 hardware provided. Locate the supplied supercharger drive belt and install between the crank pulley and supercharger pulley. Using a 1/2" ratchet, apply tension to the supercharger drive belt and secure the three M12 screws previously installed. (See Fig. 5-a, 5-b, 5-c.)



Fig. 5-a: Entry Level V3 6-Rib Application

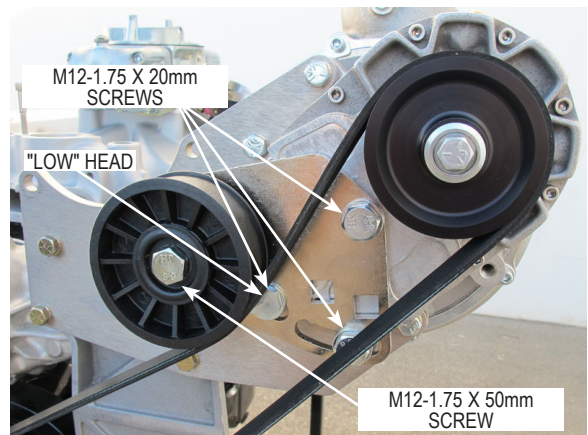

Fig. 5-b: Entry Level V3 6-Rib Application

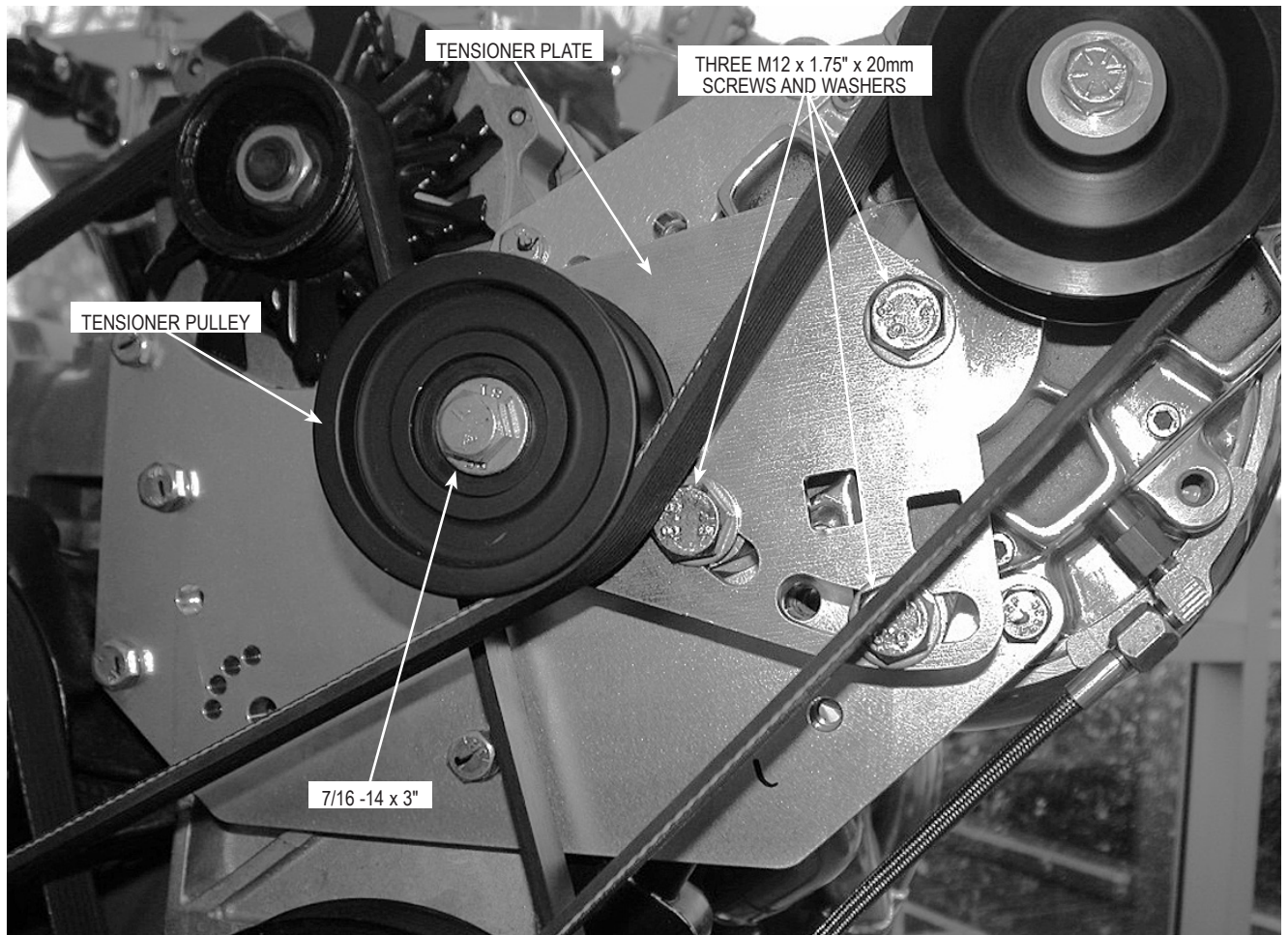

Fig. 5-c (10-Rib Application Shown)

6.1 DISCHARGE DUCTING/CARBURETOR ENCLOSURE (NON-ENTRY LEVEL KITS)

NOTE: OPTIONAL: Due to the many possible configurations of intake manifolds (with regard to carburetor flange height) a carburetor spacer may be required to obtain the necessary height for proper supercharger and discharge duct alignment. As an option, the carburetor enclosure cover may be turned around so that the inlet is facing the passenger side of the vehicle. This may be desirable on some vehicle applications with tall intake manifolds or for vehicles with other clearance issues. (See Figs. 6.1-a, 6.1-b for more detail.)

1. This optional discharge arrangement requires the supercharger to be sent into Vortech for a volute exchange to a straight discharge unit (a curved volute is originally supplied on the supercharger).
2. An extended discharge elbow must be purchased from Vortech (#4GA012-021).
3. Also a discharge elbow must be purchased from Vortech (#8M012-012).
4. Routing of the fuel line inlet to the rear of the enclosure must also be performed.

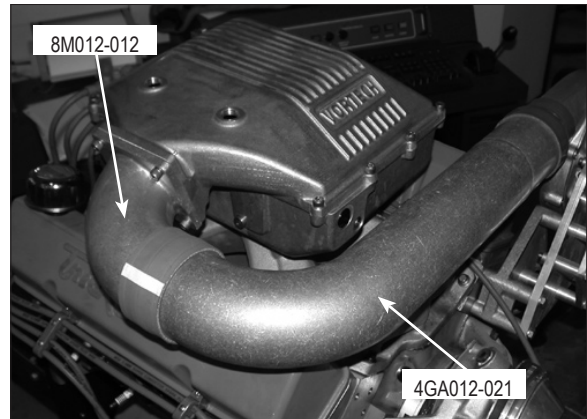

Fig. 6.1-a (Optional)



Fig. 6.1-b (Optional)

- A. Install Vortech carburetor enclosure (if not already completed) assembly #8M205-012 included in this kit. Instructions are included in the enclosure assembly.
- B. Locate the 4GP112-040 discharge assembly. Using the supplied gasket and 5/16-18 x 3/4" socket-head screws from the carburetor enclosure assembly, secure the 3/5" aluminum flange to the carburetor enclosure lid.
- C. Install the 3/5" x 2.75" 90° elbow (7S350-276) between the supercharger discharge and the 3.5" aluminum flange previously installed. Trim the ends if necessary for best fit. Secure using a #44 and #56 hose clamp.

NOTE: The 7S350-276 is made to be trimmed in order to fit, allowing for various intake manifold heights.

- D. Compressor Bypass Valve Placement: Vortech suggests attaching the compressor bypass valve (bypass valve and mounting flange are not included) onto the supercharger discharge tube. After all of the major kit components have been installed, mock-up the bypass valve and flange so that proper clearance to vehicle hood and surrounding components is confirmed. Actual valve location will vary depending on the specific application. After the bypass flange and valve are permanently mounted, connect the bypass valve vacuum port to a proper vacuum source on the engine.

6.2 DISCHARGE DUCTING/CARBURETOR HAT (ENTRY LEVEL V3 KITS)

- A. Locate the 8M106-011 carb hat assembly.
- B. Place the carb hat housing bottom side up on a non-marring surface.
- C. Place the diffuser onto the receiver groove machined into the carb hat housing. (See Fig. 6.2-a)
- D. Place the carb hat base onto the housing, making sure the diffuser seats into the base's machined groove. Orient approximately as shown. (See Fig. 6.2-b)
- E. Install the ten (10) retaining clips around the circumference with the included 1/4-20 screws. Do not tighten at this time, so the base can rotate within the hat.
- F. Temporarily place the assembly onto the carburetor so the float adjustment screws are centered within the reliefs on the base and the inlet points to the driver side.
- G. Locate the 4GP112-050 discharge assembly. Temporarily place the 90° aluminum elbow between the supercharger discharge and the carb hat inlet. Adjust the clocking of the carb hat relative to the base as needed for proper alignment. Snug one or two of the retaining clips to secure the base to the hat.
- H. Remove the hat assembly from the engine and secure the remaining retaining clips.
- I. Place the included gasket onto the carburetor's air cleaner mounting surface. Place the hat assembly into position and secure to the carburetor with the included 5/16-18 screw and gasket sealing washer.
- J. Install the 90° aluminum elbow between the supercharger discharge and the carb hat inlet. Couple to the discharge with the Ø2.75" silicone sleeve and two (2) #44 worm gear clamps. Couple to the carb hat inlet with the Ø2.75" X Ø3.0" stepped coupler, one (1) #44 worm gear clamp, and one (1) #48 worm gear clamp. (See Fig. 6.2-c)
- K. Compressor Bypass Valve Placement: Vortech suggests attaching the compressor bypass valve (bypass valve and mounting flange are not included) onto the supercharger discharge tube. After all of the major kit components have been installed, mock-up the bypass valve and flange so that proper clearance to vehicle hood and surrounding components is confirmed. Actual valve location will vary depending on the specific application. After the bypass flange and valve are permanently mounted, connect the bypass valve vacuum port to a proper vacuum source on the engine.



Fig. 6.2-a



Fig. 6.2-b

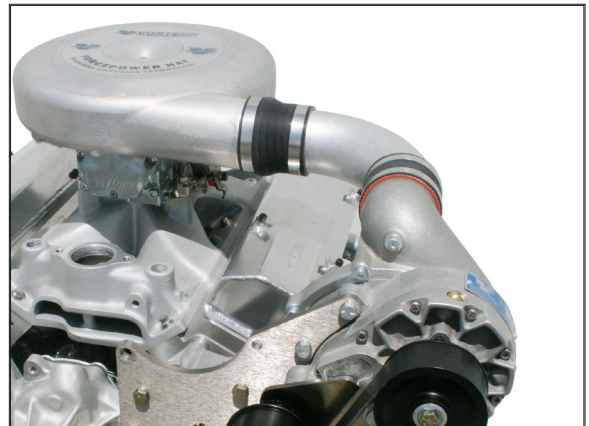

Fig. 6.2-c

7. FINAL REASSEMBLY AND CHECK

WARNING: Do not attempt to operate the vehicle until all components are installed and all operations are completed including final check.

- A. Refit the fan and shroud (if equipped).
- B. Fuel pump boost reference hose connection: Connect a suitable boost reference hose to the mechanical fuel pump (or to the regulator if an electric pump and bypass-style fuel system is employed) to a positive pressure source upstream of the throttle valve. This source can be a port (installer provided) located on the supercharger discharge tube or carb hat/enclosure. Ensure that the source that you select supplies only positive pressure under all operating conditions.
- C. Reconnect the battery.
- D. If your vehicle has gone over 15,000 miles since its last spark plug change, you will need to change the spark plugs now before test driving the vehicle.
- E. Check all fittings, nuts, bolts and clamps for tightness. Pay particular attention to oil and fuel lines around moving parts, sharp edges and exhaust system parts. Make sure all wires and lines are properly secured with clamps or tie-wraps.
- F. Check all fluid levels, making sure that your tank(s) is filled with 91 octane or higher fuel before commencing test drive.
- G. Start engine and allow to idle a few minutes, then shut off.
- H. Recheck to be sure that no hoses, wires, etc. are near exhaust headers or moving parts and for signs of any fluid leakage.
- I. Re-jet the carburetor as required. Install a boost referenced high-performance mechanical fuel pump or high performance electric fuel pump with boost referenced fuel regulator. Use a wide band O2 sensor to verify a proper air/fuel ratio (*Vortech suggests 11.0:1 for 91 octane pump fuel*).
- J. Check ignition timing to make sure it is properly set before commencing test drive.
- K. **PLEASE TAKE SPECIAL NOTE:** Operating the vehicle without all sub assemblies completely and properly installed and working may cause **FAILURE OF MAJOR ENGINE COMPONENTS**.
- L. Test drive the vehicle.
- M. Read the Street Supercharger System Owner's Manual and **RETURN THE WARRANTY REGISTRATION FORM** within thirty (30) days of purchasing your supercharger system to qualify.

For internally lubricated V3 units only

This supercharger has been factory pre-filled with special Vortech synthetic lubricant. Oil does not need to be added to a brand new unit; however a fluid level check should be performed.

Prior to operating the supercharger on the vehicle and after installation onto the vehicle:

Remove the factory installed flat-head brass shipping plug (not the dipstick) from the top of the supercharger case. Replace the sealed shipping plug with the supplied "vented" plug. Do not operate the supercharger without it. Check the supercharger fluid level.

Fluid level checking procedure:

1. Ensure that the .06" copper sealing washer is located on the dipstick base.
2. Thread the clean dipstick into the unit until it seats.
3. Once the dipstick has seated, remove the dipstick from the unit. Fluid should register in the crosshatched area on the dipstick.
4. **DO NOT OVERFILL!!!** Drain excess fluid from the unit if it is above the maximum level on the dipstick.

Check the fluid level using the dipstick at least every 2,500 miles.

Initial supercharger fluid change must be performed at 2,500 miles. The supercharger fluid must be changed at least every 7,500 miles.

Drain the fluid, refill the unit with 4 oz. of Vortech V3 lubricating fluid and then confirm proper oil level using the dipstick. **DO NOT OVERFILL!!!**

WARNING: Use of any fluid other than the special Vortech lubricant will void the warranty and may cause component failure.

(this page intentionally left blank)



ENGINEERING, INC.

*1650 Pacific Avenue, Channel Islands CA 93033-9901 • Phone: 805 247-0226
Fax: 805 247-0669 • www.vortechsuperchargers.com*