



SystemMAX II™

1986 - 1993 FORD 5.0L HO INTAKE MANIFOLDS
Kit Part Number 300-72S & 300-72BK



300-72S



300-72BK

Installation Instructions P/N 199R9991-2

NOTE: These instructions must be read and fully understood before beginning installation. If this manual is not fully understood, installation should not be attempted.

TABLE OF CONTENTS:

INTRODUCTION:	3
IMPORTANT INSTALLATION NOTES:	3
PARTS IDENTIFICATION:	3
ADDITIONAL PARTS REQUIRED:	4
TOOLS REQUIRED:	5
REMOVAL OF ENGINE ACCESSORIES:	5
INTAKE MANIFOLD REMOVAL:	6
SYSTEMAX II LOWER INTAKE INSTALLATION:	7
SYSTEMAX II UPPER INTAKE INSTALLATION:	9
INSTALLATION OF ENGINE ACCESSORIES:	10
SYSTEMS CHECK:	11
STARTING THE ENGINE:	11
TROUBLESHOOTING:	11

INTRODUCTION:

Congratulations on your purchase of the **SystemeMAX II** manifold! Holley Performance Products has written this manual for the installation of the Ford **SystemeMAX II** manifold. This manual contains all the information needed to install this system. Please read all the **WARNINGS** and **NOTES**. They contain valuable information that can save you time and money.

It is our intent to provide the best possible products for our customer; products that perform properly and satisfy your expectations. Should you need information or parts assistance, please do not return the unit to the store without first contacting technical service at 1-270-781-9741, Monday through Friday, 7 a.m. to 5 p.m. Central Time. By using this number, you may obtain any information and/or parts assistance that you may require. Please have the part number of the product you purchased when you call.

IMPORTANT INSTALLATION NOTES:

This instruction manual will take the installer through a step by step process to install the **SystemeMAX II** manifold with the engine in the vehicle. Before beginning the installation of the Holley **SystemeMAX II** manifold, several things must be considered:

1. Prior to installation, be sure the vehicle is in good running and mechanical condition. Retrieve all trouble codes from the vehicle's computer, following the manufacturer's procedure. All computer codes must be corrected **BEFORE** installation of the **SystemeMAX II** manifold. Failure to do so may result in driveability problems not associated with the **SystemeMAX II** manifold installation, and in the event of problems, will make diagnosis more difficult.
2. The vehicle will be out of service for a day or so, depending on your experience, with the manifold being installed. Considerations should be taken accordingly.
3. If the removal and installation of **SystemeMAX II** components requires removal of either the condenser or air compressor, the air conditioning system must first be evacuated. Take the vehicle to a certified air conditioning technician to recover and evacuate the air conditioning system.

DANGER! THIS TYPE OF WORK MUST BE PERFORMED IN A WELL-VENTILATED AREA. DO NOT SMOKE OR HAVE AN OPEN FLAME NEAR GASOLINE VAPORS OR AN EXPLOSION MAY RESULT CAUSING SERIOUS PERSONAL INJURY, PROPERTY DAMAGE, AND/OR DEATH.

DANGER! ALWAYS WEAR SAFETY GLASSES WHEN WORKING ON A VEHICLE. FAILURE TO WEAR EYE PROTECTION MAY RESULT IN SERIOUS EYE INJURY.

DANGER! DO NOT SMOKE OR HAVE AN OPEN FLAME PRESENT NEAR GASOLINE VAPORS OR AN EXPLOSION MAY RESULT CAUSING SERIOUS PERSONAL INJURY, DEATH, AND/OR PERSONAL PROPERTY DAMAGE.

WARNING! FOR A SAFE AND RELIABLE INSTALLATION OF THE HOLLEY SYSTEMAX II MANIFOLD, A THOROUGH KNOWLEDGE OF THE VEHICLE'S MECHANICAL AND ELECTRICAL SYSTEMS IS NECESSARY. OTHERWISE, ONLY A PROFESSIONAL MECHANIC SHOULD DO THE INSTALLATION. AN IMPROPERLY INSTALLED MANIFOLD CAN CAUSE POOR PERFORMANCE, PERSONAL INJURY, AND/OR PROPERTY DAMAGE.

NOTE: If the condenser needs to be removed, the air conditioning system will need to be evacuated. This procedure has to be done by a certified air conditioning technician with the proper recovery equipment. Releasing freon gas into the atmosphere is illegal.

PARTS IDENTIFICATION:

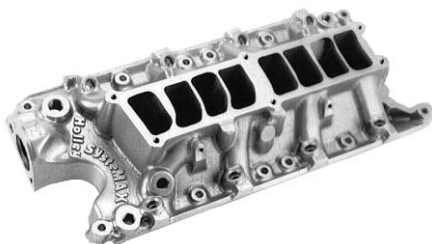

Lower Manifold



Upper Manifold



EGR Heat Shield



Cup Plugs



Rivets

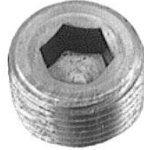

.500 - 14 NPT Plug

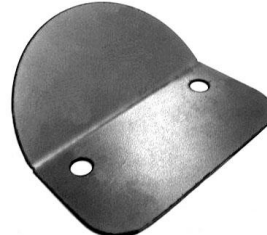

PCV Splashguard



Manifold Flange Stud



Cap Screws .3125 - 18 x 1.5



Cap Screw .3125 - 18 x 1



.3125 - 18 x 6.5 SHCS



.3125 Nut

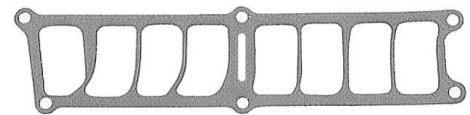

Upper to Lower Manifold Gasket

ADDITIONAL PARTS REQUIRED:

- EGR Spacer to Intake Gasket (Ford #M9464-A50)
- Throttle Body to EGR Spacer (Ford #M9933-A50 or Equivalent)
- Intake Manifold Gaskets (Felpro® Gasket, #1250 or Equivalent)
- Water Outlet Gasket (Felpro® Gasket, #35440 or Equivalent)
- Thermostat
- RTV silicone sealer
- Anti-Seize Compound
- Oil and Oil Filter
- Antifreeze

TOOLS REQUIRED:

- 1/2" Ratchet and Extensions
- 1/2" Deep Standard and Metric Socket Sets
- 3/8" Ratchet and Extensions
- Combination Wrench set – Standard and Metric
- Torque Wrench
- Spring Lock Coupler Disconnect Tool for Fuel Lines
- 1/2" Standard and Metric Socket Sets
- 3/8" Deep Standard and Metric Socket Sets
- 3/8" Standard and Metric Socket Sets
- Standard and Phillips Screwdrivers
- Gasket Scraper
- Oil Filter Wrench

REMOVAL OF ENGINE ACCESSORIES:

1. Disconnect the negative cable from the battery. Secure the cable to prevent accidental grounding. See Figure 1.



Figure 1

2. Drain the coolant from the radiator. Remove the block drain plug to drain the coolant from the block.

DANGER! COOLANT INSIDE A HOT ENGINE WILL BE UNDER PRESSURE. ALLOW THE ENGINE TO COOL BEFORE DRAINING THE COOLANT. FAILURE TO FOLLOW THIS PROCEDURE MAY RESULT IN SEVERE PERSONAL INJURY.

3. Disconnect and remove the mass air flow sensor and duct work. See Figure 2.

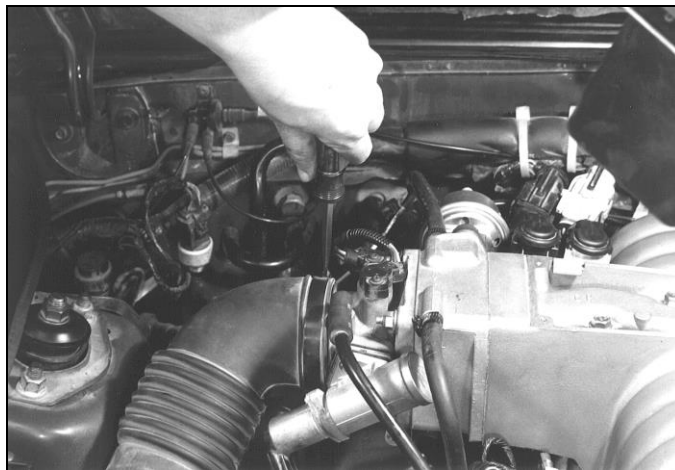

Figure 2

- The fuel pressure must be released prior to disconnecting the fuel lines or hoses. Remove the Schrader valve cap from the fuel pressure port. Attach a fuel pressure gauge to the Schrader valve. Release the fuel pressure through the gauge and into a clean metal container. Use the spring lock coupler disconnect tool to disconnect the fuel lines. See Figure 3.

DANGER! FAILURE TO RELEASE FUEL PRESSURE COULD RESULT IN UNINTENTIONAL FUEL SPRAY, WHICH COULD CAUSE A FIRE HAZARD OR SERIOUS PERSONAL INJURY. ALWAYS WEAR SAFETY GLASSES WHEN RELEASING FUEL PRESSURE.

DANGER! BEFORE DISCONNECTING OR REMOVING FUEL LINES, MAKE SURE THE ENGINE IS COLD. DO NOT SMOKE WHEN WORKING AROUND GASOLINE OR GASOLINE VAPORS! EXTINGUISH ALL OPEN FLAMES. AN OPEN FLAME, SPARK, OR EXTREME HEAT COULD RESULT IN A FIRE AND/OR EXPLOSION CAUSING SERIOUS INJURY, DEATH, AND/OR PROPERTY DAMAGE.

DANGER! USE ONLY A CLEAN METAL CONTAINER TO CAPTURE FUEL. FAILURE TO USE A CLEAN METAL CONTAINER MAY RESULT IN ACCIDENTAL FUEL SPILLAGE, WHICH COULD CAUSE A FIRE OR EXPLOSION HAZARD RESULTING IN SERIOUS INJURY, DEATH AND/OR PROPERTY DAMAGE.

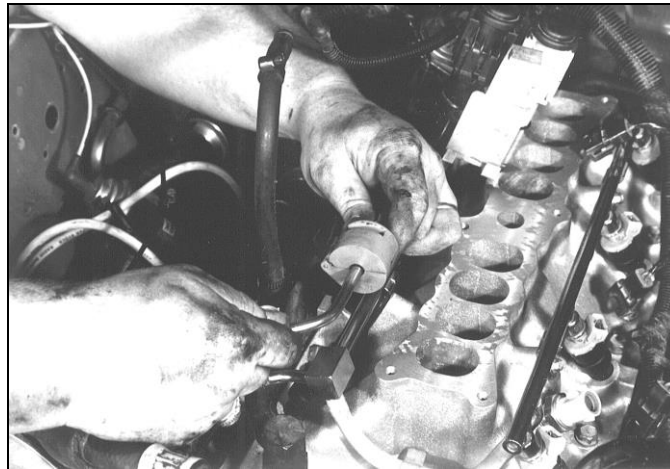

Figure 3

- Carefully mark all linkages and cables before removal.
- Carefully mark and disconnect the vacuum hoses connected to the upper and lower manifolds.
- Identify and mark each plug wire and the cylinder designation on the block. Leave the spark plug wires attached to the distributor cap, and disconnect the spark plug wires from each spark plug. Position them to avoid interference in the manifold removal and installation.
- Remove the coolant hoses from the upper and lower manifolds.

INTAKE MANIFOLD REMOVAL:

NOTE: It may be necessary to loosen or remove the accessories or accessory brackets to perform the following steps.

- Remove the cover from the top of the upper intake manifold to expose the center bolts.
- Remove the 6 bolts and lift the upper intake from the lower intake. Some models have a support bracket on the rear of the upper intake assembly. This bracket must be removed to separate the upper intake manifold from the lower intake manifold.
- Unplug the electrical connections from the sensors and the injectors located on the lower intake manifold. Keep the wiring harness out of the way by tying it to the firewall.
- When disconnecting the coolant lines from the heater at the firewall, be sure to twist hoses before removal reduce the chance of any heater core damage.
- Remove the upper radiator hose water neck and thermostat. The water neck and a thermostat will need to be installed on the new intake manifold.

- Loosen the lower intake manifold bolts a 1/2 turn in **reverse** of the torque sequence shown in Figure 4 (starting with number 12 and ending with number 1). After loosening all the lower intake bolts, the bolts can be removed.

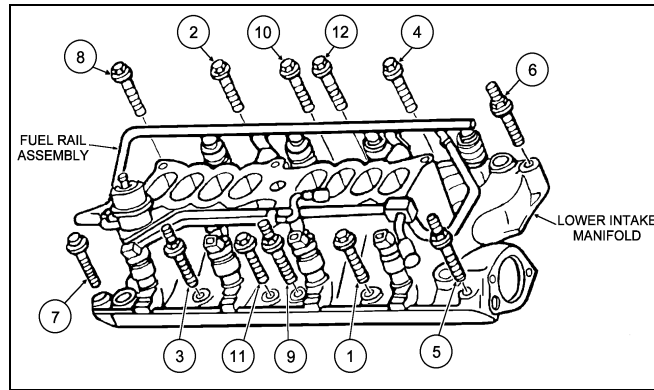

Figure 4

- Remove the lower intake manifold and place a clean shop rag or towel over the engine valley to prevent dirt and contaminants from getting into the engine. See Figure 5.
- Before cleaning, stuff the intake ports with paper towels or shop rags.

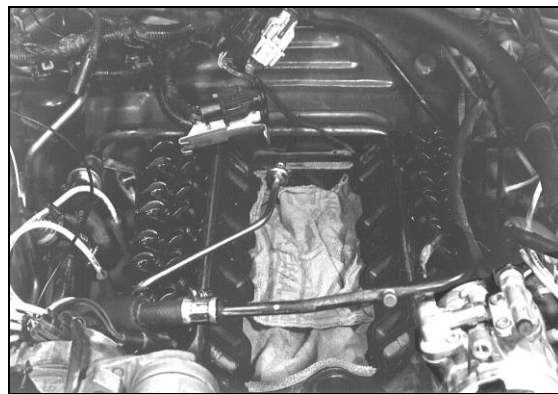

Figure 5

SystemMAX II LOWER INTAKE INSTALLATION:

- Be sure all gasket surfaces are clean and free of oils and cleaning solutions. Wipe the gasket surfaces with a clean shop rag to remove any contamination. Remove port stuffing and valley rags.
- Remove the water lines, sensors, fuel rails, and plugs from the lower manifold.
- Remove the injectors from the original manifold.
- Install the EGR heat shield and the PCV splashguard to the **SystemMAX II** lower manifold using the rivets provided.
- Install the PCV screen filter in the new lower manifold.
- Install new intake gaskets on the cylinder heads. If the front and rear seals do not have an adhesive backing, it is recommended that you use a thick bead of RTV silicone sealer instead of the gasket.
- If you are using the front and rear end seals with the adhesive back as the front and rear seals, apply a small amount of RTV silicone sealer in the corners where the cork gasket and intake gaskets intersect. Follow the instructions on the sealer before assembling.
- Apply a small amount of anti-seize compound to each intake bolt and install.
- Torque the lower intake bolts in the sequence shown in Figure 6. Torque the lower intake bolts to 15 ft./lbs., and repeat the torque sequence to a final torque of 22-24 ft./lbs.

WARNING! BE SURE TO TORQUE THE BOLTS IN THE DESIGNATED SEQUENCE TO THE CORRECT TORQUE. FAILURE TO DO SO CAN RESULT IN ENGINE DAMAGE.

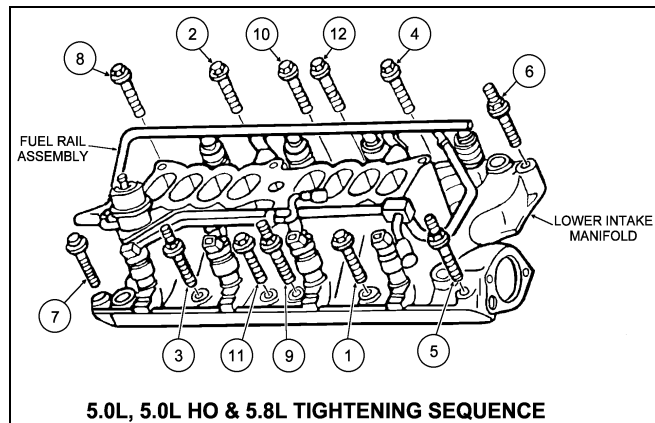

Figure 6

10. Install new O-rings on the original injectors. Install the injectors in the new manifold.

DANGER! FAILURE TO INSTALL NEW O-RINGS ON THE INJECTORS COULD CREATE A FUEL LEAK, RESULTING IN AN ENGINE FIRE, EXPOSION, PROPERTY DAMAGE, AND/OR PERSONAL INJURY.

11. Install the water lines, sensors, fuel rails, and plugs that were removed from the old manifold. See Figure 7.

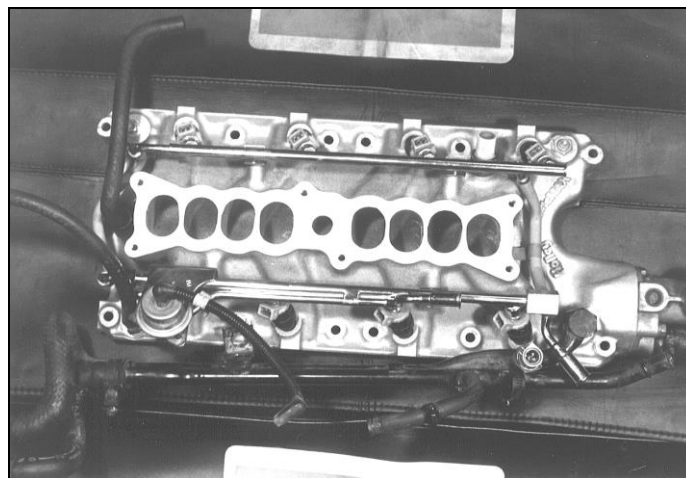

Figure 7

12. Install the fuel pressure regulator from the old manifold on to the new manifold.

13. Install the thermostat and water neck outlet removed from the original intake manifold with a new gasket. It is highly recommended that a new thermostat be installed during this procedure. Use anti-seize compound on the bolts securing the water neck. Torque the water neck bolts to 30 ft./lbs.

14. Plug any unused ports on the manifold.

15. Reconnect the wiring harness to the injectors and sensors on the lower manifold.

16. Reconnect the fuel lines, ensuring the connections snap together tightly. Reattach the safety clamps to the lines. Double-check to ensure all lines are properly connected and secure. See Figure 8.

DANGER! FAILURE TO CONNECT FUEL LINE CONNECTIONS PROPERLY MAY RESULT IN GASOLINE LEAKS, WHICH COULD CAUSE A FIRE OR EXPLOSION RESULTING IN PROPERTY DAMAGE, SERIOUS INJURY, AND/OR DEATH.

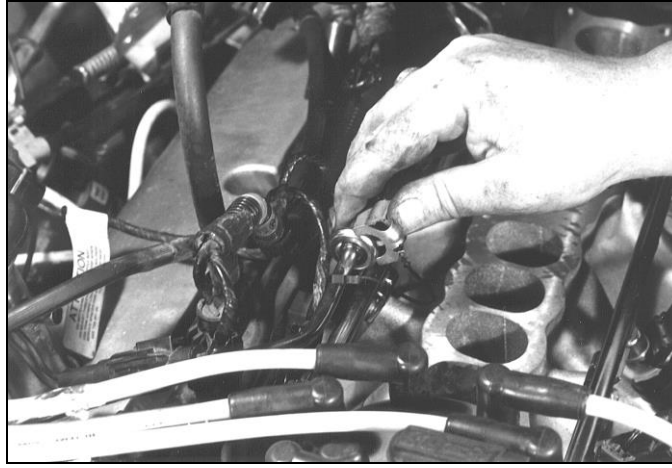

Figure 8

17. Check the condition of the bypass hose and heater hoses, and replace if necessary. Connect the bypass hose and heater hoses and then tighten securely.

SystemeMAX II UPPER INTAKE INSTALLATION:

1. If your SystemeMAX manifold is equipped with an internal EGR passage and the side of the lower manifold has a large drilled and tapped hole on the side, plug it with the supplied 1/2" pipe plug.
2. Using the gasket provided, install the upper manifold to the lower manifold. Torque to 12-18 ft./lbs.
3. Remove the 4 nuts that secure the throttle body and EGR spacer to the stock or old upper intake manifold. Remove the throttle body and EGR spacer.
4. Remove the 4 studs from the old upper intake manifold.
5. Install the 4 studs removed from the old upper intake into the new **SystemeMAX II** upper intake.
6. Install the gasket and the EGR spacer onto the studs.
7. Install the gasket and the throttle body onto the studs.
8. Install the nuts and torque to 20 ft./lbs.
9. Reconnect the throttle linkage. Check for any binding by opening and closing the throttle completely. If *any* binding is present, do not proceed any further until it is corrected.

DANGER! FAILURE TO PROPERLY REATTACH ALL THROTTLE LINKAGE CONNECTIONS MAY RESULT IN UNCONTROLLED ENGINE OR VEHICLE SPEED, WHICH COULD CAUSE PERSONAL PROPERTY DAMAGE, SERIOUS INJURY, AND/OR DEATH.

10. Install the 3/8" vacuum fitting (straight fitting) on the front side of the upper intake.

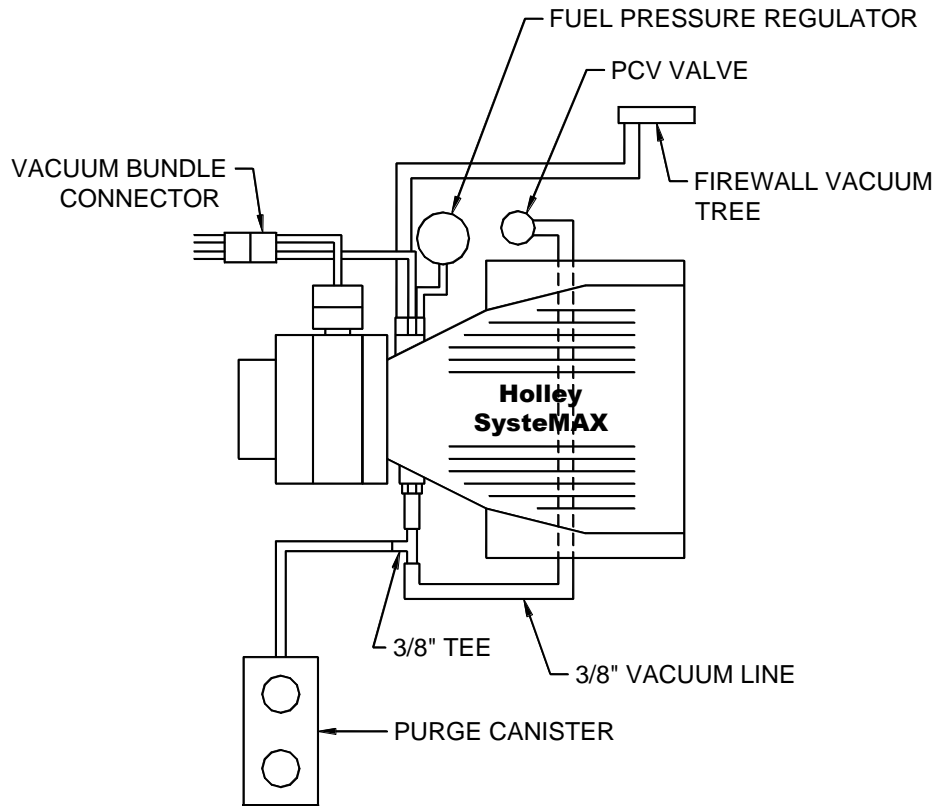

Figure 9

11. Using Figure 9 as a guide, connect the vacuum lines to the upper intake manifold. Some trimming or extension of the vacuum lines may be necessary. Connect the lines from the vacuum bundle connector to the EGR valve and the ports on the back of the manifold. Connect the fuel pressure regulator and large line from the firewall vacuum tree to the back of the manifold. Connect the PCV valve and purge canister to the front of the manifold using a 3/8" vacuum line and the supplied 3/8" Tee.
12. Connect the coolant hoses to the EGR spacer. Securely tighten all clamps.
13. Install the air intake hose and mass air flow sensor and reconnect all electrical connections. Securely tighten all fasteners.

INSTALLATION OF ENGINE ACCESSORIES:

1. Reconnect the coolant hoses from the upper and lower manifolds.
2. Fill the radiator with a 50/50 antifreeze and water mix.
3. Inspect the air filter element at this time. Replace, if necessary.
4. Drain the oil from the crankcase and remove the old oil filter. Be sure and drain the oil by removing both drain plugs. Reinstall both drain plugs. Install a new oil filter and refill the crankcase with fresh motor oil to the manufacturer's specifications.
5. Reconnect the spark plug wires to their correct cylinder designation ensuring to route the wires away from any direct sources of heat.

SYSTEMS CHECK:

NOTE: Before attempting to start the engine, check the following items:

- Are fuel lines hooked up and securely tightened?
- Are all throttle linkages and return springs connected and working properly?
- Are all vacuum hoses connected?
- Are all radiator and heater hoses connected properly?
- Has the cooling system been filled with a 50/50 mixture of anti-freeze and water?
- Are all electrical connections that were removed during the installation reconnected:
- Was the crankcase oil and oil filter changed and refilled?

STARTING THE ENGINE:

1. Reconnect the negative battery cable to the negative battery terminal.
2. Turn the key on a few times to allow the fuel pump to operate and purge the lines of air. Check for fuel leaks at this time. If any fuel leaks are present, do not attempt to start the engine before repairs are made.

DANGER! FAILURE TO REPAIR FUEL LEAKS CAN BE EXTREMELY DANGEROUS. DO NOT SMOKE WHEN WORKING AROUND GASOLINE OR GASOLINE VAPORS! EXTINGUISH ALL OPEN FLAMES. AN OPEN FLAME, SPARK, AND/OR EXTREME HEAT COULD RESULT IN A FIRE AND/OR EXPLOSION CAUSING SERIOUS INJURY, DEATH, AND/OR PROPERTY DAMAGE.

3. If the area is clear of fuel and/or fuel vapors, start the engine. If the engine turns over excessively or backfires, stop and recheck ignition timing.
4. After the engine starts, remove the shunt plug from the distributor and set the ignition timing to the specification found on your underhood decal, usually 10° BTDC, with a timing light. Tighten the distributor hold down bolt. Reinstall the shunt plug.
5. After initial startup, and the engine reaching full operation temperature, shut the engine down and allow it to cool for a minimum of 8 hours. Re-torque the lower intake manifold using the sequence from the **SystemAX II LOWER INTAKE INSTALLATION** section of this manual. Re-torque the throttle body nuts at this time.

TROUBLESHOOTING:

A	Engine backfires during initial cranking.	<ul style="list-style-type: none">- Check ignition timing with a timing light during cranking.- Check to ensure all spark plug wires are located on the appropriate spark plug.- Check for vacuum leaks.
B	Surging Idle or erratic idle.	<ul style="list-style-type: none">- Excessive fuel pressure.- Vacuum leak.- Idle speed adjusted incorrectly. See TUNING section of the SystemAX II manual.

**Holley Performance Products
1801 Russellville Road
Bowling Green, KY 42101**

Technical Service: 1-270-781-9741

**For online help, please refer to the Tech Service section of
our website: www.holley.com**

©2002 Holley Performance Products, Inc.

199R9991-2

Revision Date: 4-7-22