



## Twisted Wedge® 185, Track Heat® 185 and Twisted Wedge® Race 195 Cylinder Heads for the Ford 4.6L/5.4L 2V

Thank you for purchasing the Trick Flow Twisted Wedge® cylinder heads for your Ford 4.6L/5.4L 2V engine. Please follow the steps outlined in this instruction manual to ensure that the installation of your new cylinder heads is done correctly.

Please read all of the enclosed information before beginning any work. If you have any questions regarding installation or the written materials supplied with your new heads, contact the Trick Flow technical department at 1-330-630-1555, Monday through Friday from 9:00 am to 5:00 pm ET.

### *Project Overview*

- Review all paperwork included in the installation packet
- Inspect the condition of all components
- Verify the part numbers and quantities of each product received
- Mail the warranty card to Trick Flow
- Locate recommended tools
- Purchase the shop manual for your specific application, or take your vehicle to a qualified/certified mechanic
- Remove existing cylinder heads
- Clean and inspect the engine block
- Pre-installation assembly
- Check piston to valve clearance
- Install the new cylinder heads onto engine block
- Timing the camshafts
- Installing the cam followers
- Perform a proper break-in
- Make tuning adjustments
- Test drive and enjoy!



## ***Parts Checklist***

Please verify the part numbers and quantities of each component received. Each cylinder head is packaged with its own components.

- Assembled cylinder head
- Instruction packet
- (2) 1/4" NPT Pipe Plug (TFS-5191418NP)
- (1) 1/2" NPT Pipe Plug (TFS-5191214NP)
- (9) 1/8" NPT Pipe Plug (TFS-5191827NP)
- (1) Assembly lube package

If you are missing an item or a part was received in error, please contact Trick Flow at 1-330-630-1555, Monday through Friday from 9:00 am to 5:00 pm ET.

## ***Recommended Tools***

- Shop Manual for your specific vehicle
- Metric socket sets with 1/2, 3/8, 1/4" drives, deep and shallow
- Metric combination wrenches
- SAE hex key wrenches
- 3/8" and 1/4" swivels
- Extended reach 5/8" spark plug socket
- Torque wrenches (in-lbs and ft-lbs)
- OHC valve spring compressor TFS-90518 or equivalent
- Spark plug gap tool
- Precision straightedge
- Feeler gauge
- Modeling clay
- Harmonic balancer removal and installation tool
- Permanent marker
- Razor blade
- Adjustable setup lash adjuster

## ***Additional Parts Required***

These components are required to complete the installation of your new cylinder heads. Please refer to the Recommended Components chart on the Technical Specifications sheet for specific part numbers.

- Head gaskets (with triangular cut out for oil passage)
- Intake gaskets
- Exhaust gaskets
- Head bolts
- 3/4" reach spark plugs
- RTV sealer
- Permatex Thread Sealant with PTFE
- Cast iron ratcheting type chain tensioners
- 8mm front cover bolts (Windsor applications)
- Power Steering Tank Bracket Adapter (1999-2001 Windsor and all Truck applications) (TFS-51954PSB)

## ***Tested and Highly Recommended***

These components and lubricants were used during testing and are highly recommended:

- High volume oil pump and pick-up
- Motorcraft® 5w-20 Premium Synthetic Blend Motor Oil
- Trick Flow roller followers (TFS-51800510)
- Trick Flow hydraulic lash adjusters (TFS-21400008)
- Trick Flow complete timing kit (TFS-51800500) or adjustable (TFS-51800520)
- Ford Racing head change gasket and head bolt kit (M-6067-D46)
- Permatex Thread Sealant with PTFE

## ***Remove Existing Cylinder Heads***

Follow the repair manual for your specific vehicle for removing existing cylinder heads. If you have any questions, please contact Trick Flow at 1-330-630-1555.

**NOTE: The OEM head bolts are torque-to-yield, they cannot be reused. Loosen cam gear bolts before removing timing chains and cylinder heads from vehicle if they are to be re-used. Mark chain guides and tensioner arms right and left prior to removal.**



## ***Clean and Inspect the Engine Block***

With the existing cylinder heads removed, inspect the cylinder bores for scratches, ridges, and cracks. Remove all traces of the gaskets and any oil or grease that may be present by wiping the surface with brake cleaner or solvent. It is very important to not to scratch the deck surface of the engine block as these engines use MLS (multi-layer steel) head gaskets. Prevent loose debris from going into cylinders by putting clean paper towels or rags in them.

Check the deck surfaces for flatness by laying a precision straightedge across the deck lengthwise and sticking a .002" feeler gauge under it. If the feeler gauge fits anywhere under the straightedge, the block will need to be decked or head gasket failure or cam seizure will result.

After cleaning the head bolt hole threads and removing any engine coolant from them, carefully remove the paper towels from the cylinders and discard. Using new paper towels clean the cylinders and coat the cylinder walls with a thin film of engine oil to protect them from corrosion.

If you wish to add exhaust headers to your vehicle, lay them on the cross member by the engine mounts before the new cylinder heads go on. This will save time and frustration if you do not have a vehicle lift at your disposal.

## Pre-Installation Assembly

Please follow the steps below before your new cylinder heads are bolted on to the engine block.

1. Remove cylinder heads from packaging, inspect for shipping damage.
2. Locate the hardware kit for each cylinder head.
3. Find a clean, suitable table or work bench to assemble your new cylinder heads on.
4. Your new cylinder heads are not left or right side specific up to this point. Take a permanent marker and mark one cylinder head “L” left or driver side, and mark the other “R” right or passenger side.

The flat end of the cylinder head casting will be towards the front of the engine on the right side, the recessed end of the cylinder head casting will be toward the front of the engine on the left side.

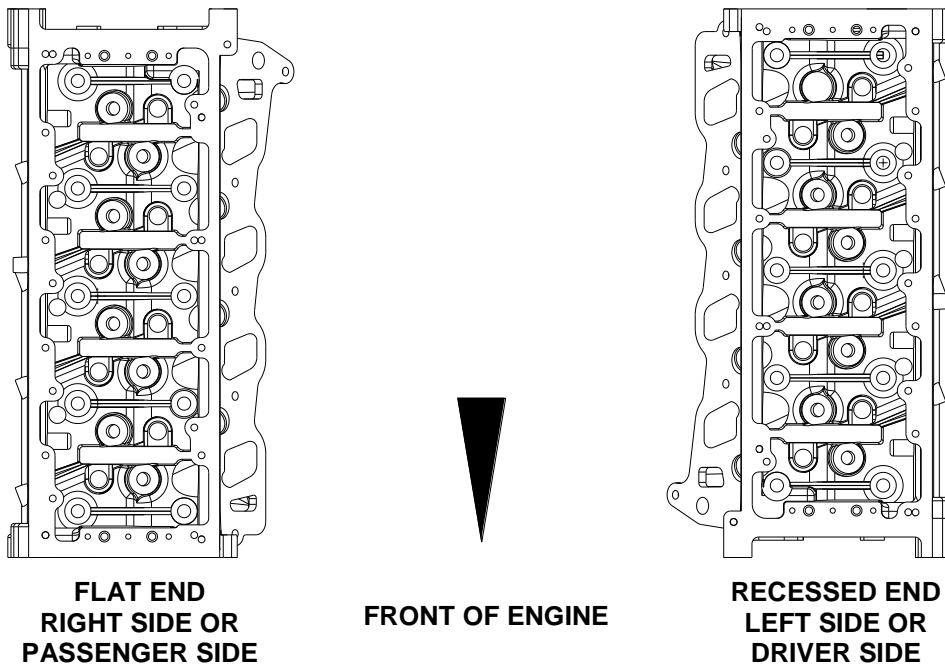

5. The black 1/8" NPT oil restrictor plug should already be installed in the triangular pocket in deck of cylinder head. This pipe plug has a 1/8" hole through the center of it. The oil restrictor plug controls the amount oil going into the cylinder head from the engine block. Your engine will have low oil pressure if this plug is NOT installed.

**OIL RESTRICTOR PIPE  
PLUG HERE ON  
BOTH HEADS**



- Install the other (solid) 1/8" NPT pipe plugs into the oil passages on the deck and exhaust side of the cylinder head casting. Make sure the pipe plugs on the deck are recessed from the deck surface. **Pipe plugs have a sealant applied to them already, but we strongly suggest applying additional Permatex Thread Sealant with PTFE. DO NOT OVER-TIGHTEN!**

INSTALL 1/8" npt  
PLUG HERE ON  
BOTH HEADS

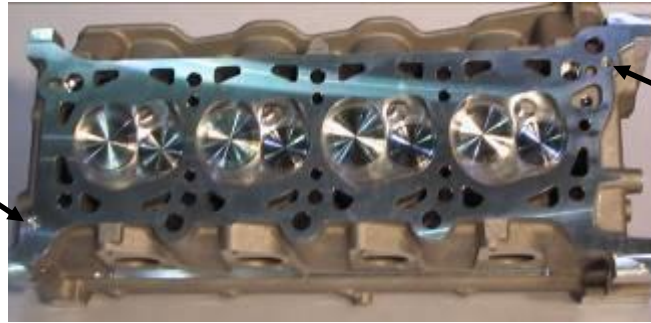

INSTALL 1/8" npt  
PLUG HERE ON  
BOTH HEADS

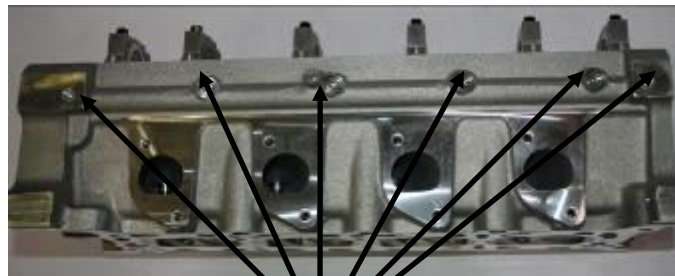

INSTALL 1/8" NPT  
PLUGS HERE ON  
BOTH HEADS

- On the left cylinder head casting, install an 1/8" NPT pipe plug on the chain tensioner mounting pad facing the firewall in the vehicle.
- On the right cylinder head casting, install an 1/8" NPT pipe plug on the chain tensioner mounting pad facing the firewall in the vehicle.
- The chain tensioner oil feed holes facing the front of the vehicle DO NOT get plugged.
- Install (2) 1/4" NPT & (1) 1/2" NPT pipe plugs on both ends of heads into main oil passages. **Although the plugs are already coated thread sealer, we strongly suggest applying additional Permatex Thread Sealant with PTFE. Please note that if the plug leaks, it may be nearly impossible to tighten the plug after installation in the vehicle.**

**IMPORTANT!**

**FILL THE 1/4" HEX PLUG FLUSH WITH RTV SEALANT TO SEAL THE FRONT COVER PRIOR TO INSTALLATION.**

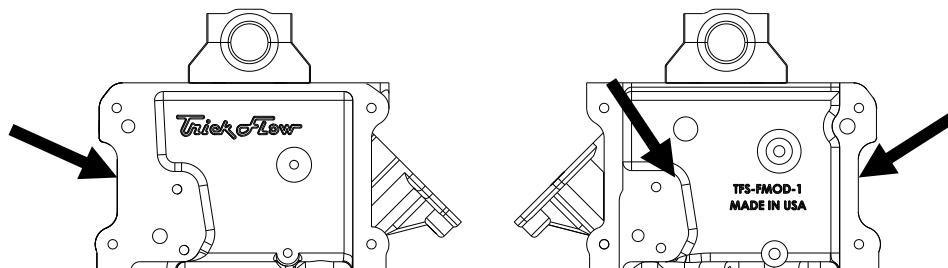

- Trick Flow recommends using new lash adjusters with your new cylinder heads. Lash adjusters with high miles or usage can be worn or broken internally. If the lash adjusters must be re-used, clean them thoroughly, and bleed-out all the cleaners or solvents.

12. Bleed down all the lash adjusters; this will make installing the cam followers much easier later. Lash adjusters can be easily bled down using a bench vise and a 1/4" socket to protect the follower ball.
13. Coat outside body of the lash adjusters with clean engine oil, and install them into the new cylinder head.
14. Remove the upper cam caps on one cylinder head at a time. Only remove the two inner M8 x 70mm cam cap bolts, the outer socket head cap screws do not need to be removed. The cam caps are precision machined in matched sets, it is imperative that the upper caps remain with the corresponding lower caps they came with for proper assembly and journal life.



15. Pre-lube the cam cap journals and install the camshaft into the cylinder head. Make sure the camshafts correspond with the cylinder head you are putting it in. The left camshaft goes in the left cylinder head; the right camshaft goes in the right cylinder head. Apply assembly lube to the thrust surfaces on the front cam journals.



16. Apply assembly lube on the cam journals and upper cam caps. Install each upper cam cap to the corresponding journal number marked on the intake side of the cap assembly. Coat the cam cap bolts with light oil.



17. Torque the M8 x 70mm cam cap bolts to 150 in-lbs or 12.5 ft-lbs in pairs starting in the center of the head and working your way to the ends.

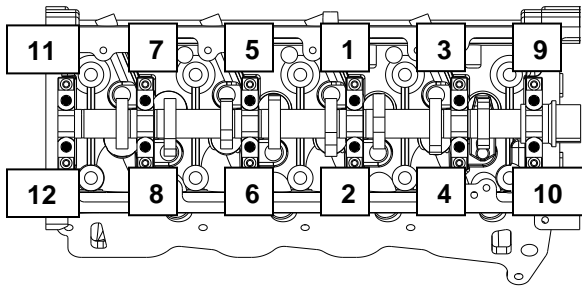

18. After the cam caps are torqued to spec, camshaft should rotate freely (do not turn excessively because of pre-lubing). Check the camshaft thrust is within specification. (0.002" - 0.008")



19. It is necessary to install the exhaust side head bolts on the cylinder head prior to placing the cylinder heads in the vehicle (not enough clearance by the shock towers). Split rubber spacers could be fabricated and/or some gasket/bolts kits include them. Lubricate the head bolt per manufacturer's requirements.
20. Some applications require exhaust studs. The studs should be installed into the cylinder heads before they go on the vehicle. If OEM exhaust manifolds are used check clearances to the cylinder head casting prior to installing it in the vehicle; modify as necessary.
21. Your new cylinder heads are now ready to be installed on the vehicle. Take a moment to clear your work area of any obstructions. Place protective equipment over vehicle fenders, front end, hood, etc.

## ***Piston-to-Valve Clearance***

Your new cylinder heads have been designed to increase piston-to-valve clearance over OEM Ford PI cylinder heads. However, Trick Flow suggests checking piston-to-valve clearance with your specific combination of parts.

Checking piston-to-valve clearance can easily be done with the left side cylinder head on #6 cylinder. Install the crank timing gear at TDC position. Place approximately 1/4" thick piece of clay onto the piston face. Apply engine oil to the clay.

On the work bench, install the cam followers for cylinder #6 using adjustable solid set-up lash adjusters with the left camshaft at #6 TDC. Install the left cylinder head onto the left engine bank with old head gasket, using two old head bolts to secure the cylinder head to the block. Line up the two colored links on the timing chain with the dots on the cam gears and crank gear. Install cam gear, tensioner arm, and tensioner. Rotate crankshaft clockwise two full revolutions. Remove the cylinder head and view the impressions in the clay from the valves. Use a razor blade to cross-section the clay where the valves left impressions to measure piston-to-valve clearance (0.080" minimum clearance is recommended). Clean the clay off of piston and cylinder head. Remove the setup lash adjuster and cam followers.

**NOTE: OEM short blocks with dish pistons, piston-to-valve clearance is closest to the edge where the dish transitions to flat area.**

## ***Collapsed Lash Adjuster Clearance***

Collapsed lash adjuster clearance is the distance between the camshaft base circle and roller on the follower without the hydraulic preload of the lash adjuster. Your new cylinder heads have been designed for **0.015"-0.025"** clearance using the OEM lash adjusters and followers.

To check the lash adjuster clearance, simply bleed all of the oil out of a lash adjuster and install it into the cylinder head with the follower and camshaft. Push the lash adjuster down by hand, and measure between the camshaft base circle and roller on the follower with feeler gauges.

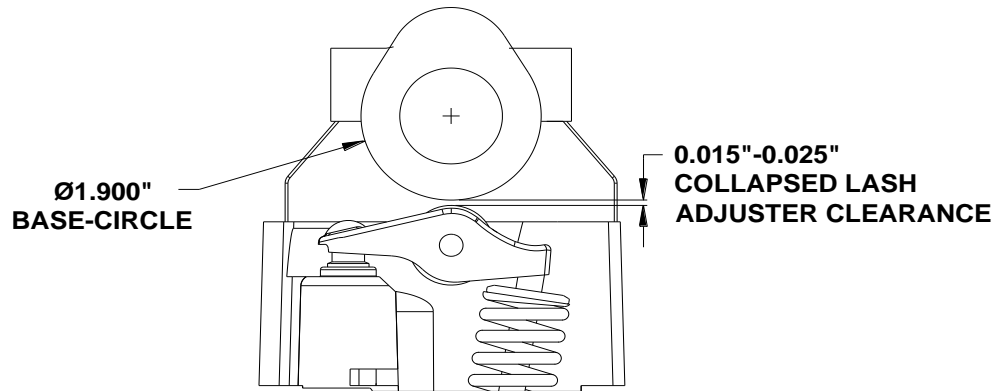

## ***Installation onto Cylinder Block***

1. Make certain the cylinder head decks are clean, the dowel locator bushings are clean and installed in the block completely, and all the cylinders are clear of debris, towels, rags, and coolant.
2. Rotate the crankshaft to #1 TDC. The crank gear keyway will be at the 10:30 position, and the timing dot will be at the 6:00 position.
3. Place the corresponding head gasket on the engine block. Ensure the triangular oil hole cutout is in correct location. This will be towards the front on the left side (driver-side), and toward the rear on the right (passenger-side). Depending on what engine block you have, the oil hole may be in a different location within the triangle cut-out compared to the pictures below (pictures shown are of a 2002 Romeo cast iron block).

**OIL SUPPLY HOLE  
LEFT OR  
DRIVER-SIDE**



**OIL SUPPLY HOLE  
RIGHT OR  
PASSENGER-SIDE**



4. Set the cylinder heads onto the engine block; make certain not to damage the gasket while aligning the cylinder head to the dowel locators.

**TECH TIP: Install 3/8" wood dowels in head bolt holes to help align the cylinder head while setting it into place.**





5. Remove the rubber spacers and install the other head bolts using the manufacturer recommended lubricant.
6. Torque the head bolts/studs using manufacturer recommended torque values in the following pattern.

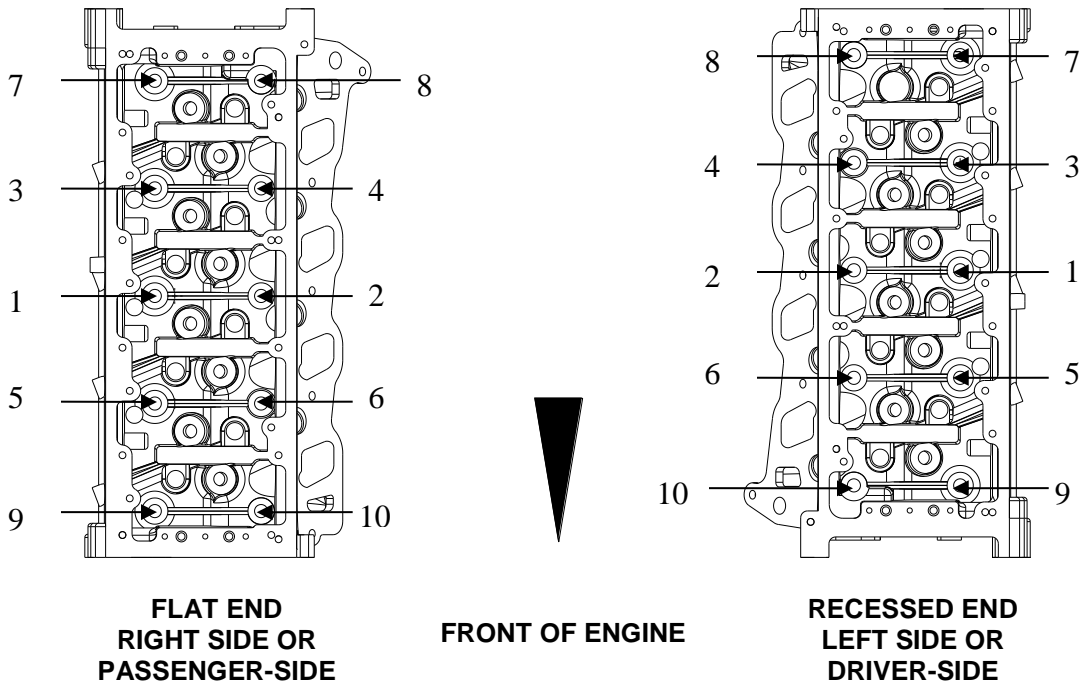

**IF USING OEM STYLE TORQUE-TO-YIELD HEAD BOLTS, APPLY LIGHT ENGINE OIL TO THREADS AND TORQUE HEAD BOLTS TO THESE VALUES IN (3) STAGES.**

**Stage One: Tighten to 30 ft.-lbs. or 40Nm**

**Stage Two: Tighten an additional 90 degrees**

**Stage Three: Tighten an additional 90 degrees**

**TECH TIP: Draw a reference line on the bolt head and on the cylinder head next to the head bolt. This will show you the two 90 degree torque steps and make it easy to see which bolts have already been torqued.**

## Timing the Camshafts

1. It is much easier to time the engine and assemble all the timing components without the cam followers installed. The engine should be a #1 TDC. Follow the diagram for timing mark locations.

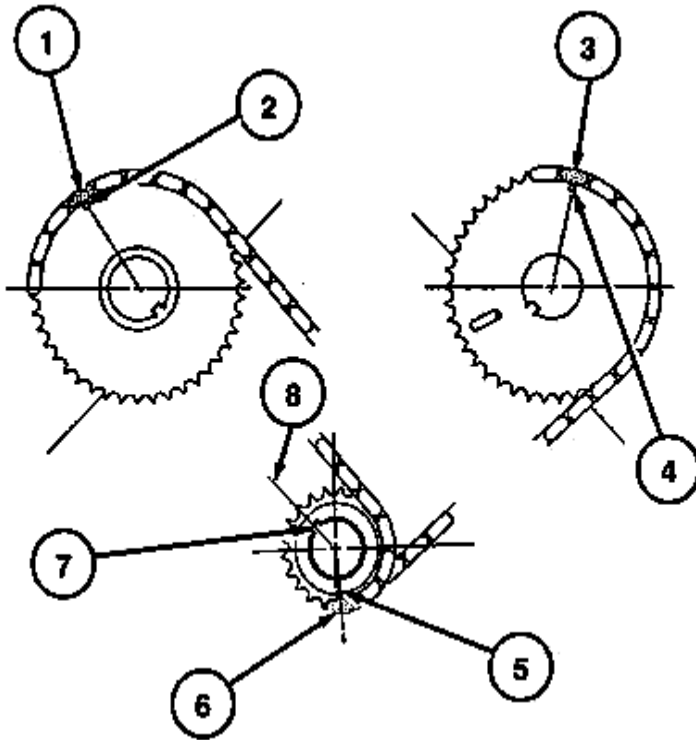

- 1, 3, and 6: DARK LINKS ON CHAIN
- 2, 4, and 5: MARKS ON GEARS
- 7: KEYWAY ON CRANK
- 8: #1 TDC KEY POSITION AT 10:30

2. Start with the left (driver-side) cam gear, cam gear spacer, crank timing gear, tensioner arm.

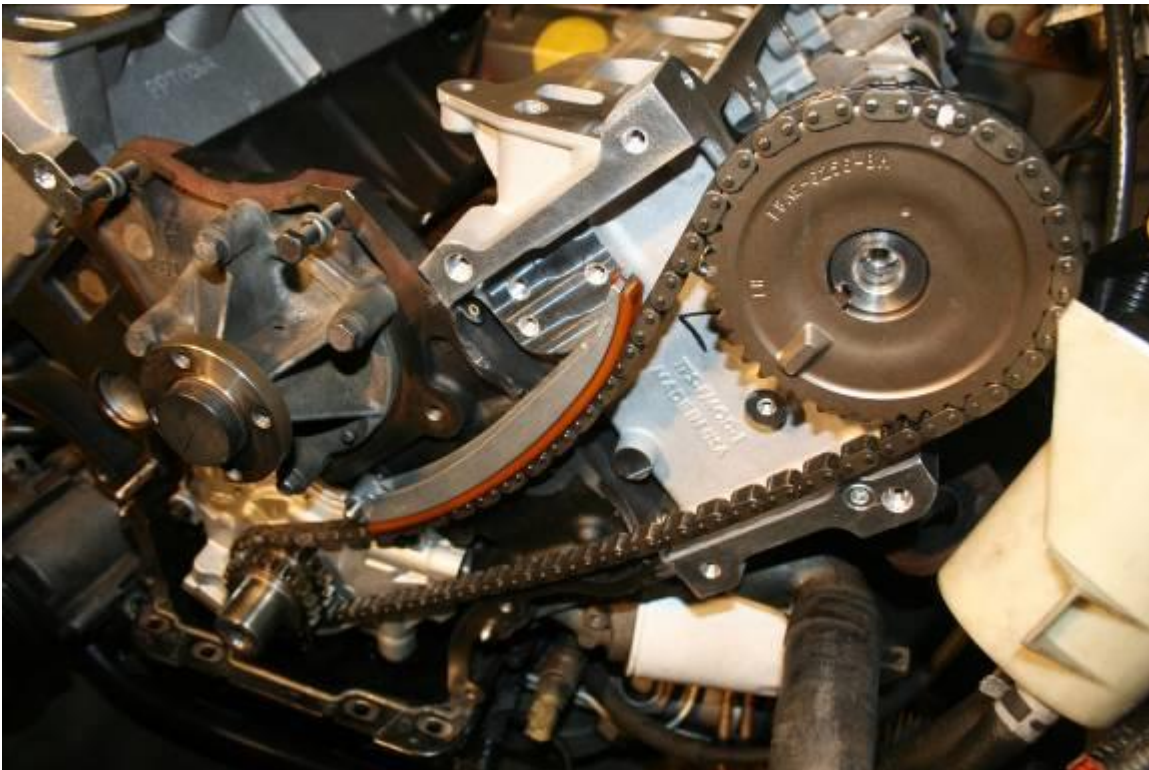

3. Install the left (driver-side) chain tensioner. Collapse the tensioner and place a pin into the hole to hold the tensioner as you install it onto the cylinder head. A bench vise with a 1/16 hex key wrench works well. Torque the bolts to **15-22 ft.-lbs.**



4. Install the right (passenger-side) cam gear, cam gear spacer, crank timing gear, tensioner arm, tensioner.
5. Torque cam gear bolts to **95-100 ft.-lbs.**
6. Install the chain guides.

**RIGHT SIDE ARM  
HAS EXTENDED  
MOUNT BOSS**



7. This is what your project should look like up to this point.



## Installing the Cam Followers

Trick Flow recommends soaking the cam followers in motor oil for a least an hour before installation. New OEM replacement type cam followers are not lubricated. Rotate each roller in the oil to ensure oil penetrates the needle bearings.

**Install cam followers in the following order. Lubricate valve tips and lash adjuster balls with assembly lube.**

With the engine at #1 TDC, install intake cam followers #1, #2, #3, #4, #5 and #8.

With the engine at #1 TDC, install exhaust cam followers #1, #2, #3, #7 and #8.

With the engine at 180° clockwise from #1 TDC, install intake cam followers #2 and #7.

With the engine at 180° clockwise from #1 TDC, install exhaust cam followers #5 and #6.

With engine rotated an additional 180°, install cam followers #6 intake and #4 exhaust.



## Finishing the Installation

Install your crank trigger wheel and then install the front cover. Check the OEM gaskets on your front cover to make sure there are no tears; replace if necessary. **APPLY RTV SEALER TO THE PAN/ENGINE BLOCK JOINTS, HEAD AND BLOCK JOINTS, HEAD AND VALVE COVER JOINTS, AND 1/4" NPT HEX PLUGS ON THE END OF YOUR NEW CYLINDER HEADS.**

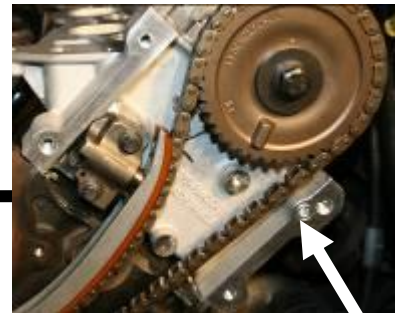
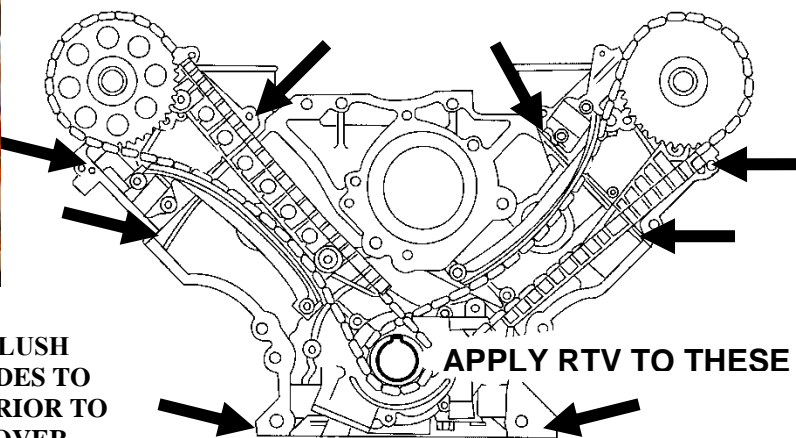

**IMPORTANT!**  
FILL 1/4" HEX PLUGS FLUSH  
WITH RTV ON L & R SIDES TO  
SEAL FRONT COVER PRIOR TO  
INSTALLING FRONT COVER

**APPLY RTV TO THESE LOCATIONS**

**Follow your vehicle repair manual for re-installing other components to complete project.**

## Break-In and Tuning

To ensure long life and trouble-free use, allow 2-4 hours of normal driving time before running the engine hard. This will allow adequate time for the valvetrain to fully break-in.

NOTE: On pollution controlled motor vehicles, please consult the shop manual, for your specific vehicle, for tuning specifications.

Visit [TrickFlow.com](http://TrickFlow.com) for up-to-date product information, more high performance parts for the Ford 4.6L/5.4L engines, technical articles/videos, and dealer locations near you.

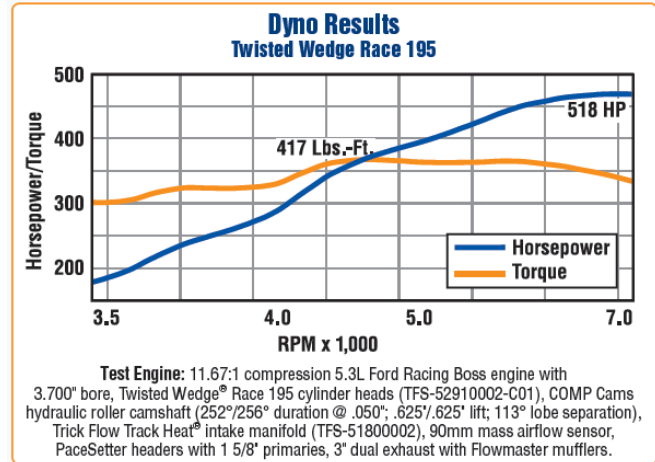
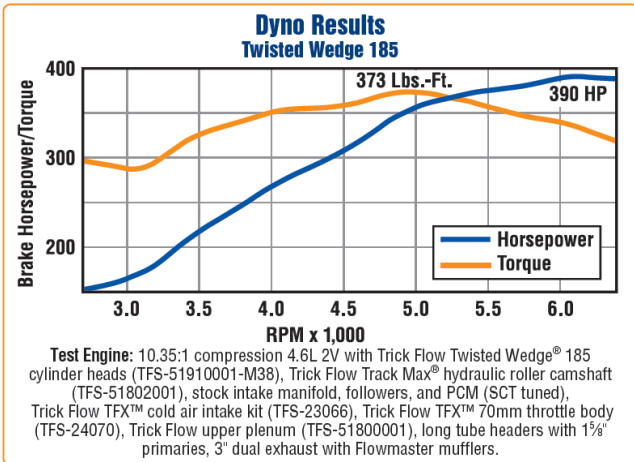

**Airflow Results**  
**Twisted Wedge 185**

Lift Value	Intake Flow CFM	Exhaust Flow CFM
.100"	58	49
.200"	125	101
.300"	175	143
.400"	224	174
.500"	250	179
.600"	252	188

Tests conducted at 28" of water (pressure).  
Bore size: 3.562"; exhaust with 1¼" pipe.

**Airflow Results**  
**Twisted Wedge Race 195**

Lift Value	Intake Flow CFM	Exhaust Flow CFM
.100"	61	51
.200"	131	105
.300"	191	152
.400"	234	183
.500"	262	195
.600"	278	199

Tests conducted at 28" of water (pressure).  
Bore size: 3.700"; exhaust with 1¼" pipe.

## Horsepower How-To Series: Ford 4.6L Mustang— Installing Trick Flow Track Max® Camshafts and Twisted Wedge® Cylinder Heads DVD



Horsepower and Trick Flow teamed up to produce a How-To DVD for enthusiasts that covers the technical aspects of upgrading camshafts and cylinder heads to get more performance from Ford's 4.6L 2V engines, using straightforward and easy to understand demonstrations.

Includes camshaft and valvetrain removal and installation, cylinder head disassembly and installation, timing system removal and replacement, and how to properly degree camshafts. Plus detailed tech tips, specs, sample dyno runs, and a huge buyer's guide that contains all the right parts, tools, and accessories you'll need to get the performance gains you want the first time.

TFS-DVD-1 DVD, each

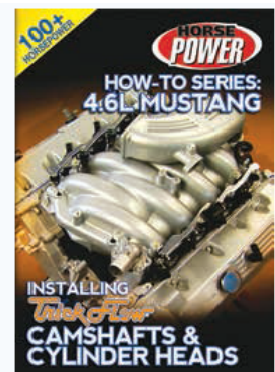

## Trick Flow Cylinder head Specification/ Data sheet

<b>Head Material:</b>	A356-T61 Aluminum
<b>Comb. Chamber volume:</b>	M38: 38cc CNC Profiled C01/M44: 44cc CNC Profiled
<b>Intake port volume:</b>	185cc Fast-As-Cast 195cc CNC Competition Ported
<b>Intake port dimensions:</b>	M38/M44: 1.500" x 1.880" OEM Ford PI C01: 1.700" x 2.000" OEM Ford PI
<b>Intake port location:</b>	Stock
<b>Intake valve diameter:</b>	M38: 1.840"/46.7mm (TFS-51800211) M44: 1.840"/46.7mm (TFS-51800213) C01: 1.900"/48.3mm (TFS-52900211)
<b>Intake valve seat:</b>	M38/M44: Ductile iron (TFS-51900271) C01: Ductile Iron (TFS-52900271)
<b>Valve angles:</b>	9°
<b>Exhaust port volume:</b>	M38/M44: 93cc Fast-As-Cast C01: 95cc CNC Competition Ported
<b>Exhaust port dimensions:</b>	1.470" x 1.250" D-shaped
<b>Exhaust port location:</b>	Stock
<b>Exhaust valve diameter:</b>	M38: 1.450"/36.8mm (TFS-51800212) M44: 1.450"/36.8mm (TFS-51800214) C01: 1.470"/37.3mm (TFS-52900212)
<b>Valve guide material:</b>	Intake: Trick-Alloy powdered metal (TFS-51900251) Exhaust: Trick-Alloy powdered metal (TFS-51900252)
<b>Valve seal:</b>	01/02/03/04: Viton® fluoroelastomer (TFS-51800454) 05/06/01-C01: Viton® Fluoroelastomer (TFS-52900454)
<b>Exhaust valve seat:</b>	Ductile iron (TFS-51900272)
<b>Valve seat angles:</b>	45°x multi-angle
<b>Valve spring pockets:</b>	1.180"
<b>Valve spring cups:</b>	05/06: 1.100" (TFS-52900434) C01: 1.110" (TFS-52900444)
<b>Valve spring retainers:</b>	01/02/03/04: Chromoly steel 7°x 0.875" O.D. (TFS-51900423) 05/06: Chromoly steel 7°x 1.100" O.D. (TFS-52900423) C01: Chromoly steel 7°x 1.100" O.D. (TFS-52900424)
<b>Valve stem locks:</b>	7° machined steel, triple groove (TFS-51900444) 7° machined steel (TFS-52900450)
<b>Valve springs: 01-M38/02-M44</b>	.940/1.050" O.D. beehive (TFS-16519) 90 lbs. @ 1.600" installed height 205 lbs. @ 1.020" open 209 lbs. per inch rate .600" max. valve lift
<b>Valve springs: 03-M38/04-M44</b>	1.00/1.06 O.D. beehive (TFS-16125) 125 lbs. @ 1.600" installed height 275 lbs. @ 1.020" open 275 lbs. per inch rate .580" max. valve lift
<b>Valve springs: 05-M38/06-M44/C01</b>	1.10 O.D. dual (TFS-16521) 150 lbs. @ 1.500" installed height 290 lbs. @ 0.900" open 233 lbs. per inch rate .650" max. valve lift
<b>Minimum bore:</b>	M38/M44: 3.552" C01: 3.572"
<b>Weight each bare:</b>	30 lbs.

### Trick Flow cylinder head recommended components.

<b>Lash adjusters:</b>	TFS-21400008 (OEM hydraulic style)
<b>Rocker arms:</b>	TFS-51800510 (OEM style roller follower) TFS-52900510 (Ford GT style)
<b>Miscellaneous data:</b>	Has provisions to attach Romeo or Windsor OE valve covers 8mm Front Cover end bolt holes Provision for "cooling mod" Driver-side rear of head Drill into water-jacket in Cast-in Dimple; Tap up to 3/4" NPT
<b>Head gasket:</b>	M38/M44: TFS-5180901L and TFS-5180901R C01: TFS-5180902L and TFS-5180902R (Must use head gaskets with a minimum bore diameter of 3.700")
<b>Intake gasket:</b>	TFS-51800922
<b>Exhaust gasket:</b>	Fel Pro MS 92568
<b>Head bolts/studs:</b>	TFS-92008
<b>Thread sealant:</b>	Permatex Thread Sealant with PTFE
<b>Spark plugs:</b>	Motorcraft SP432



## **Ultimate Bolt-On Performance® Lifetime Warranty**

Trick Flow Specialties guarantees original, unmodified cylinder head castings against manufacturing defects. Trick Flow's liability is limited to replacing the casting.

The valves, valve guides, valve seats, valve job, valve springs, valve spring retainers, valve locks, rocker arm studs, guide plates, and valve stem seals included on assembled Trick Flow Specialties cylinder heads are warranted to the original purchaser to be free from defects in materials and workmanship for a period of two years from the date of purchase. All other Trick Flow Specialties products are warranted to be free from defects in materials and workmanship for a period of 90 days. There are no mileage limitations.

### **Extent of Warranty**

Customers who believe they have a defective product should return it to the dealer from which they purchased or ship it freight prepaid to Trick Flow Specialties along with proof of purchase and a complete description of the problem. If a thorough inspection indicates defects in materials or workmanship, our sole obligation is to repair or replace the product.

This warranty is only if the product is properly installed, subjected to normal use and service, did not fail due to owner negligence or misuse, and has not been altered or modified.

Trick Flow Specialties warranties do not cover any installation or removal costs.

Trick Flow Specialties is not liable for consequential damages for breach of contract of any warranty in excess of the purchase price of the product sold.

### **PROPOSITION 65 WARNING**

This product may contain one or more substances or chemicals known to the state of California to cause cancer, birth defects or other reproductive harm.

TRICK FLOW SPECIALTIES  
285 WEST AVE.  
TALLMADGE, OHIO 44278  
(330) 630-1555

Trick Flow Specialties®, Trick Flow®, TFS® and Twisted Wedge® are registered trademarks of Trick Flow Specialties.

The replaceable cam bearing journals are protected under U.S. patent number 8,231,278.

Viton® is a registered trademark of DuPont Performance Elastomers.

