

DODGE/CHRYSLER
6.4L Challenger
Supercharger System
Installation Instructions
2011-2012 Model Years*

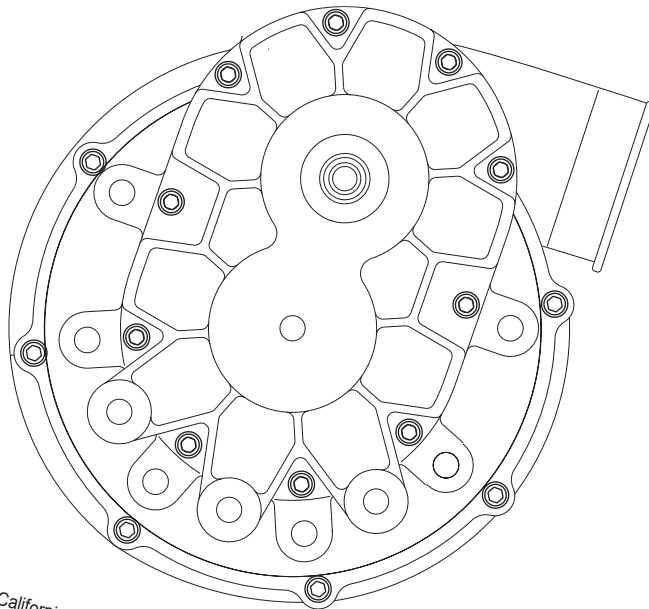

*Legal in California for racing vehicles which may never be used upon a highway.



ENGINEERING, INC.

1650 PACIFIC AVENUE • CHANNEL ISLANDS, CA 93033-9901 • (805) 247-0226
FAX (805) 247-0669 • www.vortechsuperchargers.com

FOREWORD

This manual provides information on the installation, maintenance and service of the Vortech supercharger kit expressly designed for this vehicle. All information, illustrations and specifications contained herein are based on the latest product information available at the time of this publication. Changes to the manual may be made at any time without notice. Contact Vortech Engineering for any additional information regarding this kit and any of these modifications at (805) 247-0226 7:00am - 3:30pm PST.



Take note of the following before proceeding:

1. Proper installation of this supercharger kit requires general automotive mechanic knowledge and experience. Please browse through each step of this instruction manual prior to beginning the installation to determine if you should refer the job to a professional installer/technician. Please contact your dealer or Vortech Engineering for possible installers in your area.
2. **This product was designed for use on stock (*un-modified, OEM*) vehicles.** The PCM (*computer*), engine, transmission, drive axle ratios and tire O.D. must be stock. If the vehicle or engine has been modified in any way, check with Vortech prior to installation and use of this product.
3. Use only premium grade fuel with a minimum of 91 octane (*R+M/2*).
4. Always listen for any sign of detonation (*knocking/pinging*) and discontinue hard use (*no boost*) until the problem is resolved.
5. Vortech is not responsible for any clutch, transmission, drive-line or engine damage.

Exclusions from Vortech warranty coverage considerations include, but not limited to:

1. Neglect, abuse, lack of maintenance, abnormal operation or improper installation.
2. Continued operation with an impaired vehicle or sub-system.
3. The combined use of Vortech components with other modifications such as, but not limited to, exhaust headers, aftermarket camshafts, nitrous oxide, third party PCM programming or other such changes.

© 2014 VORTECH ENGINEERING, INC.

All rights reserved. No part of this publication may be reproduced, transmitted, transcribed, or translated into another language in any form, by any means without written permission of Vortech Engineering, Inc.

TABLE OF CONTENTS

FOREWORD	ii
TABLE OF CONTENTS.....	iii
IMPORTANT NOTES	iv
TOOL & SUPPLY REQUIREMENTS.....	v
PARTS LISTS.....	vi
1. PREPARATION AND REMOVAL	1
2. FRONT FASCIA REMOVAL	2
3. HARMONIC DAMPER DOWEL PIN INSTALLATION	3
4. COOLANT & POWER STEERING RESERVOIR REPLACEMENT.....	4
5. SUPERCHARGER MOUNTING PLATE INSTALLATION	5
6. SUPERCHARGER INSTALLATION	8
7. AIR INLET INSTALLATION	9
8. CHARGE AIR COOLER / DISCHARGE ASSEMBLY INSTALLATION	11
9. RESERVOIR AND WATER PUMP ASSEMBLY AND INSTALLATION	14
10. CHARGE AIR COOLER RADIATOR INSTALLATION	15
11. CHARGE AIR COOLER HOSE ROUTING DIAGRAM.....	16
12. FINAL ASSEMBLY AND CHECKING	17

OFF-HIGHWAY USE

When driving vehicle on non-public roads (off-road applications such as racing/high RPM) Vortech strongly recommends reducing the factory spark plug gap down to .032”.

COPYRIGHT NOTICE

This product is protected by state common law, copyright and/or patent. All legal rights therein are reserved. The design, layout, dimensions, geometry and engineering features shown in this product are the exclusive property of Vortech Engineering, INC.. This product may not be copied or duplicated in whole or part, abstractly or fundamentally, intentionally or fortuitously, nor shall any design, dimension, or other information be incorporated into any product or apparatus without prior written consent of Vortech Engineering, Inc.

Dodge/Chrysler Hemi Cars Installation Instructions

Congratulations on selecting the best performing and best backed automotive supercharger available today... the VORTECH® Supercharger!

Before beginning this installation, please read through this entire instruction booklet and the Street Supercharger System Owner's Manual which includes the Automotive Limited Warranties Program and the Warranty Registration form.

Vortech supercharger systems are performance improving devices. In most cases, increases in torque of 30-35% and horsepower of 35-45% can be expected with the boost levels specified by Vortech Engineering. This product is intended for use on healthy, well maintained engines. Installation on a worn-out or damaged engine is not recommended and may result in failure of the engine as well as the supercharger. **Vortech Engineering is not responsible for engine damage.**

Installation on new vehicles will not harm or adversely affect the break-in period so long as factory break-in procedures are followed.

For best performance and continued durability, please take note of the following key points:

1. Use only premium grade fuel 91 octane or higher (R+M/2).
2. The engine must have stock compression ratio.
3. If the engine has been modified in any way, check with Vortech prior to using this product.
4. Always listen for any sign of detonation (pinging) and discontinue hard use (no boost) until problem is resolved.
5. Before beginning installation, replace all spark plugs that are older than 1 year or 10,000 miles with original heat range plugs as specified by the manufacturer and reset timing to factory specifications (follow the procedures indicated within the factory repair manual and/or as indicated on the factory underhood emissions tag). **Do not use platinum spark plugs unless they are original equipment.** Change spark plugs every at least 15,000 miles and spark plug wires at least every 50,000 miles.

TOOL & SUPPLY REQUIREMENTS:

- Factory Repair Manual
- 3/8" Socket and Drive Set: SAE & Metric
- 1/2" Socket and Drive Set: SAE & Metric
- Adjustable Wrench
- Open End Wrenches: 3/8", 7/16", 1/2", 9/16"
- Flat #2 Screwdriver
- Phillips #2 Screwdriver
- Drill Motor
- 1/8", 3/16", 1/4", 27/64" Drill Bits
- 3/16" Allen Wrench
- Wire Strippers and Crimpers
- Utility Knife
- Thread-lock Compound (LOCTITE 242 or 248)

If your vehicle has in excess of 15,000 miles since its last spark plug change, then you will also need:

- Spark Plug Socket
- NEW Spark Plugs





2011-2012 6.4L Automatic Challenger Tuner Kit

Part No. 4CL218-164L
PARTS LIST

IMPORTANT: Before beginning installation, verify that all parts are included in the kit. Report any shortages or damaged parts immediately.

PART NO.	DESCRIPTION	QTY	PART NO.	DESCRIPTION	QTY
008110	SMALL SILVER DIE CUT DECAL	2	4CL112-030*	AIR INLET ASSY, HEMI CHAL	1
008130	LICENSE PLATE FRAME, VORTECH	1	4CL112-084	AIR DISCH ASSY, 11-12 6.4L H	1
008341	VORTECH CHARGE COOLER DECAL	1	5W001-093	HARNESSE EXTENSION, ETC, 2011	1
008447	1 YR S/C STRT INFO PKG ASY VOR	1	8N006-020	WATER COOLR, FLDYN DUAL PASS	1
009035	S/C LUBE, BOTTLED, VORT 3-PACK	1	8N105-220*	WATER TANK ASSY, 2011 6.4 HEMI	1
2A046-106	BELT PREMIUM 104.5", GATES	1	8N107-190*	WATER PUMP MTG ASSY, 07 CHGR	1
2F329-134	V3 S/C ASY, 2011 6.4L HEMI CHA	1	8N201-394	WELDED,CORE ASSEMBLY,HEMI	1
4CL020-020	INSTR MAN, '11 6.4L HEMI CHAL.	1			
4CL010-160	BRKT, FLDYNE CHALLENGER DRVR1				
4CL010-170	BRKT, FLDYNE CHALLENGER PASS 1				
4CL110-070	PWR STEERING ASSY, 6.4L HEMI	1			
2A017-251	SPACER, .63" OD X .326" ID X .25	2			
4CL010-261	MTG BLOCK, P/S, 2011 6.4 HEMI	1			
4CL055-010	RESERVOIR, P/S, 6.4L HEMI	1			
4CL055-020	RESERVOIR, COOLANT, 6.4L HEMI	1			
7P375-075	3/4" HOSE BARB UNION, BRASS	1			
7P500-036	ELBOW, 1/2 NPT, STRT, 45 DEG	1			
7P500-078	1/2 NPT X 3/4 HOSE FIT STRT	1			
7R002-010	#10 SAW TYPE F SS HOSE CLAMP	2			
7R004-007	STEPLESS CLAMP, 28.6 X 7MM WIDE	2			
7U038-030	HOSE, P/S, 3/4 ID	1.5			
4CL110-084	S/C MTG BRKT ASY,11-12 HEMI A6	1			
008725	CAP, TAMPER PROOF, VORT S/C	2			
2A017-016	PILOT, 6203/5 BRG, 3/8 SCREW	1			
2A017-093	SPACER, S/C PULLEY, .093"	1			
2A017-105-222B	SPCR, BLK 1"OD X .328"ID X 2.225	7			
2A017-462	SPACER, IDLER SMOOTH 6RIB	1			
2A017-156	SPCR, SM IDLER, DBL BRG JACK	1			
2A017-876-12	SPACER, .875 OD X .475 LONG	2			
2A036-136	S/C PULLEY 3.60" 6 GROOVE W/FL	1			
2A040-051	PLY RETAINER, TAMPER PRF CAP	2			
2A040-061	RETAINER CUP, VORT S/C PLY	2			
2A042-080	BELT, GATES 20MM, 80 TOOTH	1			
2A017-251	SPACER, .63"OD X .326"ID X .25	2			
2D070-159	LARGE BEARING,EXTENDED DRIVE	2			
2D070-171	JACKSHAFT, C5, H900, 1INCH	1			
4CL010-010	BRK, PWR STR MTG, 07 CHR	1			
4CL010-020B	PLATE, HEAD, MTG, BLK ANODIZE	1			
4CL010-044B	SC, MTG, PLT, BLACK ANODIZE	1			
4CL016-011	HUB, PWR STR PLY, HEMI CAR	1			
4CL017-011	SPACER, IDLER, 2011 6.4	1			
4CL016-021	PULLEY, PWR STR, HEMI CAR	1			
4CL116-350	IDLER ASSY, 20MM GILMER, SRT8	1			
4FD017-011	PILOT, 6203/5 BRG, 1/2 SCREW	1			
4FT017-080	SPCR, COOLER SUPPORT	1			
4GR032-032	PULLEY,JACKSHAFT,C5,20MM,32T	1			
4GR116-300	IDLER ASSY, 20MM GILMER, C5	1			
4HS017-041	SPACER, LOWER S/C PLT S2000	2			
4NZ030-041	BEARING HSG, 350Z	1			
7A250-075	1/4-20 X .75 SHCS PLTD	6			
7A312-152	5/16-18 X 1.5 SHCS, ZN PLT	4			
7A375-124	3/8-16 X 1-1/4 HHCS, G5, PLATE	4			
7A375-225	3/8-16 X 2-1/4 HXHD G8	1			
7B375-075	3/8-24 X 3/4" GR8 HXHD BOLT	1			
7B375-150	3/8-24 X 1-1/2 GR8 HX	1			
7C012-100	12MM X 100MM X 1.75 HXHD BOLT	1			
7C080-066	M8 X 1.25 X 65 HXHD CL10.9	1			
7C080-090	M8 X 1.25 X 90 HXHD CL10.9	7			
7C080-100	M8 X 1.25 X 100 HXHD ZN PLT	3			
7C080-120	BOLT, 8MM X 120MM X 1.25 HXHD	1			
7G010-175	12MM X 1.75 NUT	1			
7J012-092	12MM WASHER, FLAT	1			

*SEE PAGE VII FOR INDIVIDUAL COMPONENTS IN ASSEMBLY



2011-2012 6.4L Automatic Challenger Tuner Kit (cont'd)

Part No. 4CL218-164L
PARTS LIST

IMPORTANT: Before beginning installation, verify that all parts are included in the kit. Report any shortages or damaged parts immediately.

PART NO.	DESCRIPTION	QTY	PART NO.	DESCRIPTION	QTY
008110	SMALL SILVER DIE CUT DECAL	2	7E010-075	#12 X 3/4" SHT METL SCRW HEX	8
008130	LICENSE PLATE FRAME, VORTECH	1	7J250-001	1/4 WASHER, SAE, PLTD	7
008341	VORTECH CHARGE COOLER DECAL	1	7P375-075	3/4" HOSE BARB UNION, BRASS	5
008447	1 YR S/C STRT INFO PKG ASY VOR	1	7P500-026	1/2NPT X 3/4 BARB 90° BRASS	2
009035	S/C LUBE, BOTTLED, VORT 3-PACK	1	7P500-075	1/2NPT X 3/4 HOSE FIT STRT NIC	5
2A046-106	BELT PREMIUM 104.5", GATES	1	7R007-001	NYLON RATCHET CLAMP 1-1/8"	19
2F329-134	V3 S/C ASY, 2011 6.4L HEMI CHA	1	7U038-000	3/4" HEATER HOSE	9'
4CL020-020	INSTR MAN, '11 6.4L HEMI CHAL.	1	7U038-012	HOSE, 3/4 DIA 90°, 4 X 12 LEGS	5
4CL010-160	BRKT, FLDYNE CHALLENGER DRVR1	1	7U038-150	HOSE, 3/4 D X 150° MOLDED HOSE	1
4CL010-170	BRKT, FLDYNE CHALLENGER PASS 1	1	7U100-044	TIE WRAP, 4" NYLON	10
4CL110-070*	PWR STEERING ASSY, 6.4L HEMI	1	7U100-055	TIE WRAP, 7.5" NYLON	10
4CL110-084*	S/C MTG BRKT ASY, 11-12 HEMI A6 1	1	8N055-030	TANK, WATER TRIANGLE SHAPE	1
4CL110-110	ASSY, DAMPER PIN, HEMI	1	8N055-050	PLASTIC CAP, SURGE TANK	1
4GR010-110	GUIDE, DWL PIN INST	1	7P500-034	1/2NPT X 3/4 BARB 90°, NICKEL	2
7C014-095	M14-1.5 X 95MM SHCS	1	7P500-035	FITTING, 1/2 NPT X 3/4 BARB X	2
7U250-019	DOWEL PIN, 1/4X1/2 +.001"	1	4CL010-290	BRKT, SURGE TANK, FILL '11 6.4	1
7U250-026	DRILL BUSHING, 1/4 ID, 3/8 OD, 1/2L	1	8N056-060	SURGE TANK, PLASTIC	1
4CL112-084	AIR DISCH ASSY, 11-12 6.4L HEMI	1	7F375-016	3/8-16 HX NUT	1
4CL010-270	BRKT, DUCT SUPRT, P. SIDE, 6.4	1	2A017-881-01	SPACER, .875 OD X .532 LONG	1
4CL010-300	BRKT, DUCT SUPRT, REAR, 6.4	1	7J375-044	3/8 SAE WASHER, PLTD	2
4CL012-074	DISCHARGE DUCT "A" COATED	1	7A375-350	3/8-16 X 3.5" HX HD GR5	1
4CL012-084	DISCHARGE DUCT "B" COATED	1	4CL010-280	MTG BRKT, CAC, 2011 6.4 HEMI	1
4CL012-094	DISCH TUBE "C", 2011-12 6.4L H	1	4CL010-160	BRKT, FLDYNE CHALLENGER DR	1
7P750-502	REDUCER, 3/4" TO 1/2" COUPLER	1	4CL010-170	BRKT, FLDYNE CHALLENGER PA	1
7PS275-100	SLEEVE, BLACK, 2.750D X 1.0	1	8N107-190	WATER PUMP MTG ASSY, 07 CHGR 1	1
7PS275-300	SLEEVE, BLACK, 2.75ID X 3.0	3	5W001-011	16-14 GA RING TERM .26" HOLE	1
7PS350-277	ELBOW, SIL, 3.5X2.75 90°, BLK	1	5W001-013	14-16 GA BUTT CONN BLU INSUL	2
7P375-156	3/8 X 3/8 X 5/32 MALE BARB TEE	1	5W001-024	MINI ATC FUSE TAP	1
7R002-016	#16 SAE TYPE F SS HOSE CLAMP	2	5W001-025	FEMALE SLIDE, INSULATED, MINI	1
7R002-044	#44 SAE TYPE F SS HOSE CLAMP	9	5W001-054	18 GA FUSE HOLDER	1
7R002-056	#56 SAE TYPE F SS HOSE CLAMP	1	5W014-030	14GA STRD WIRE BLACK	5
7U030-046	5/32" VACUUM LINE	5'	7R003-027	ADEL CLAMP, 1-11/16"	1
7U034-016	1" GS HEATER HOSE	.25'	8F001-402	PUMP, WATER, PIERBURG	1
8D001-004	COMPRESS BYPASS VALVE, G2	1	8N100-001	NYLON MOUNTING KIT	1
8H040-075	FILTER, 1" BYPASS VALVE	1	8N201-394	WELDED, CORE ASSEMBLY, HEMI 1	1
4CL112-030	AIR INLET ASSY, HEMI CHAL	1	*SEE PAGE VI FOR INDIVIDUAL COMPONENTS IN ASSEMBLY		
4CL010-180	BRKT, CHALLENGER AIR INLET	1			
4CL012-030	DUCT, INLET 08 HEMI CHALLENGER	1			
7A250-039	1/4-20 X 3/8" SHCS ZINC PLTD	2			
7J250-001	1/4 WASHER, SAE, PLTD	2			
7R002-056	#56 SAE TYPE F SS HOSE CLAMP	1			
7R002-080	#80 SAE TYPE F SS HOSE CLAMP	1			
7S500-351	INLET SLEEVE, HEMI, 5 X 3.5	1			
8H040-235	AIR FILTER, 4" FLG X 7.0L	1			
7P500-009	1/2" X 90 HOSE BARB UNION	1			
7U030-036	1/2" OIL DRAIN HOSE	4'			
8H040-300	AIR FILTER 300C	1			
7U032-020	3/8 P/S HOSE	32"			
5W001-093	HARNESSE EXTENSION, ETC, 2011 1	1			
8N006-020	WATER COOLR, FLDYN DUAL PASS 1	1			
8N105-220	WATER TANK ASSY, 2011 6.4 HEMI 1	1			
4CL010-190	BRKT, CAC TANK, HEMI	1			
7A250-050	1/4-20 X .50 SHCS GR8 ZINC PLT	4			
7A250-051	1/4-20 X .50 HHCS GR5 ZINC PLT	2			
7A250-101	1/4-20 X 1 HHCS ZINC PLTD	1			



2011-2012 6.4L Manual Challenger Tuner Kit

Part No. 4CL218-174L

PARTS LIST

IMPORTANT: Before beginning installation, verify that all parts are included in the kit. Report any shortages or damaged parts immediately.

PART NO.	DESCRIPTION	QTY	PART NO.	DESCRIPTION	QTY
008110	SMALL SILVER DIE CUT DECAL	2	7P375-075	3/4" HOSE BARB UNION, BRASS	1
008130	LICENSE PLATE FRAME, VORTECH	1	7P500-036	ELBOW, 1/2 NPT, STRT, 45 DEG	1
008341	VORTECH CHARGE COOLER DECAL	1	7P500-078	1/2 NPT X 3/4 HOSE FIT STRT	1
008447	1 YR S/C STRT INFO PKG ASY VOR	1	7R002-010	#10 SAW TYPE F SS HOSE CLAMP	2
009035	S/C LUBE, BOTTLED, VORT 3-PACK	1	7R004-007	STEPLESS CLAMP, 28.6 X 7MM WIDE	2
2A046-106	BELT PREMIUM 104.5", GATES	1	7U038-030	HOSE, P/S, 3/4 ID	1.5
2F329-134	V3 S/C ASY, 2011 6.4L HEMI CHA	1	4CL110-110*	ASSY, DAMPER PIN, HEMI	1
4CL020-020	INSTR MAN, '11 6.4L HEMI CHAL.	1	4CL112-030*	AIR INLET ASSY, HEMI	1
4CL010-160	BRKT, FLDYNE CHALLENGER DRVR1	1	4CL112-084*	AIR DISCH ASSY,HEMI CAR, G2	1
4CL010-170	BRKT, FLDYNE CHALLENGER PASS 1	1	5W001-093	HARNES EXTENSION, ETC, 2011	1
4CL110-064	S/C MTG BRKT ASY,11-12 HEMI M6 1	1	8N006-020	WATER COOLR, FLDYN DUAL PASS	1
008725	CAP, TAMPER PROOF, VORT S/C	2	8N105-220*	WATER TANK ASSY, 2011 6.4 HEMI	1
2A017-016	PILOT, 6203/5 BRG, 3/8 SCREW	1	8N107-190*	WATER PUMP MTG ASSY, 07 CHGR	1
2A017-093	SPACER, S/C PULLEY, .093"	1	8N201-394	WELDED,CORE ASSEMBLY,HEMI	1
2A017-105-222B	SPCR, BLK 1"OD X .328"ID X 2.225	7			
2A017-462	SPACER, IDLER SMOOTH 6RIB	1			
2A017-156	SPCR, SM IDLER, DBL BRG JACK	1			
2A017-876-12	SPACER, .875 OD X .475 LONG	2			
2A036-136	S/C PULLEY 3.60" 6 GROOVE W/FL	1			
2A040-051	PLY RETAINER, TAMPER PRF CAP	2			
2A040-061	RETAINER CUP, VORT S/C PLY	2			
2A017-251	SPACER, .63"OD X .326ID X .25	2			
2A042-080	BELT, GATES 20MM, 80 TOOTH	1			
2D070-159	LARGE BEARING,EXTENDED DRIVE	2			
2D070-171	JACKSHAFT, C5, H900, 1INCH	1			
4CL010-230	PLT, SUP, REAR, 09 5.7L M6 HEM	1			
4CL010-221B	PLATE, CYL HEAD 09-10 5.7L HEM	1			
4CL010-044B	SC, MTG, PLT, BLACK ANODIZE	1			
4CL016-011	HUB, PWR STR PLY, HEMI CAR	1			
4CL017-011	SPACER, IDLER, 2011 6.4 HEMI	1			
4CL016-021	PULLEY, PWR STR, HEMI CAR	1			
4CL116-350	IDLER ASSY, 20MM GILMER, SRT8	1			
4FD017-011	PILOT, 6203/5 BRG, 1/2 SCREW	1			
4FT017-080	SPCR, COOLER SUPPORT	1			
4GR032-032	PULLEY,JACKSHAFT,C5,20MM,32T	1			
4GR116-300	IDLER ASSY, 20MM GILMER, C5	1			
4HS017-041	SPACER, LOWER S/C PLT S2000	2			
4NZ030-041	BEARING HSG, 350Z	1			
7A250-075	1/4-20 X .75 SHCS PLTD	6			
7A312-152	5/16-18 X 1.5 SHCS, ZN PLT	4			
7A375-124	3/8-16 X 1-1/4 HHCS, G5, PLATE	4			
7A375-225	3/8-16 X 2-1/4 HXHD G8	1			
7B375-075	3/8-24 X 3/4" GR8 HXHD BOLT	1			
7B375-150	3/8-24 X 1-1/2 GR8 HX	1			
7C012-100	12MM X 100MM X 1.75 HXHD BOLT	1			
7C080-066	M8 X 1.25 X 65 HXHD CL10.9	1			
7C080-090	M8 X 1.25 X 90 HXHD CL10.9	7			
7C080-100	M8 X 1.25 X 100 HXHD ZN PLT	3			
7C080-120	BOLT, 8MM X 120MM X 1.25 HXHD	1			
7G010-175	12MM X 1.75 NUT	1			
7J012-092	12MM WASHER, FLAT	1			
7J312-000	5/16 FLAT WASHER-SAE	11			
7J375-044	3/8 SAE WASHER, PLTD	4			
7J500-002	1/2" WASHER, SPLIT LOCK	1			
7K250-001	1/4" AN WASHER	6			
7U100-069	KEY, 3/16 SQUARE X .73 LONG	1			
7U100-073	KEY, 3/16 SQUARE X 1.375 LONG	1			
7U100-084	SNAP RING, EXT DRV HOUSING	1			
7X100-027	WAVE WASHER, LARGE, V2 INPUT	1			
4CL110-070	PWR STEERING ASSY, 6.4L HEMI	1			
2A017-251	SPACER, .63" OD X .326" ID X .25	2			
4CL010-261	MTG BLOCK, P/S, 2011 6.4 HEMI	1			

*SEE PAGE IX FOR INDIVIDUAL COMPONENTS IN ASSEMBLY



2011-2012 6.4L Manual Challenger Tuner Kit (cont'd)

Part No. 4CL218-174L
PARTS LIST

IMPORTANT: Before beginning installation, verify that all parts are included in the kit. Report any shortages or damaged parts immediately.

PART NO.	DESCRIPTION	QTY	PART NO.	DESCRIPTION	QTY
008110	SMALL SILVER DIE CUT DECAL	2	7P500-026	1/2NPT X 3/4 BARB 90° BRASS	2
008130	LICENSE PLATE FRAME, VORTECH	1	7P500-075	1/2NPT X 3/4 HOSE FIT STRT NIC	5
008341	VORTECH CHARGE COOLER DECAL	1	7R007-001	NYLON RATCHET CLAMP 1-1/8"	19
008447	1 YR S/C STRT INFO PKG ASY VOR	1	7U038-000	3/4" HEATER HOSE	9'
009035	S/C LUBE, BOTTLED, VORT 3-PACK	1	7U038-012	HOSE, 3/4 DIA 90°, 4 X 12 LEGS	5
2A046-106	BELT PREMIUM 104.5", GATES	1	7U038-150	HOSE, 3/4 D X 150° MOLDED HOSE	1
2F329-134	V3 S/C ASY, 2011 6.4L HEMI CHA	1	7U100-044	TIE WRAP, 4" NYLON	10
4CL020-020	INSTR MAN, '11 6.4L HEMI CHAL.	1	7U100-055	TIE WRAP, 7.5" NYLON	10
4CL010-160	BRKT, FLDYNE CHALLENGER DRVR1	1	8N055-030	TANK, WATER TRIANGLE SHAPE	1
4CL010-170	BRKT, FLDYNE CHALLENGER PASS 1	1	8N055-050	PLASTIC CAP, SURGE TANK	1
4CL110-064*	S/C MTG BRKT ASY, 11-12 HEMI M6 1	1	7P500-034	1/2NPT X 3/4 BARB 90°, NICKEL	2
4CL110-070*	PWR STEERING ASSY, 6.4L HEMI	1	7P500-035	FITTING, 1/2 NPT X 3/4 BARB X	2
4CL110-110	ASSY, DAMPER PIN, HEMI	1	4CL010-290	BRKT, SURGE TANK, FILL '11 6.4	1
4GR010-110	GUIDE, DWL PIN INST	1	8N056-060	SURGE TANK, PLASTIC	1
7C014-095	M14-1.5 X 95MM SHCS	1	7F375-016	3/8-16 HX NUT	1
7U250-019	DOWEL PIN, 1/4X1/2 +.001"	1	2A017-881-01	SPACER, .875 OD X .532 LONG	1
7U250-026	DRILL BUSHING, 1/4 ID, 3/8 OD, 1/2L	1	7J375-044	3/8 SAE WASHER, PLTD	2
4CL112-030	AIR INLET ASSY, HEMI	1	7A375-350	3/8-16 X 3.5" HX HD GR5	1
4CL010-180	BRKT, CHALLENGER AIR INLET	1	4CL010-280	MTG BRKT, CAC, 2011 6.4 HEMI	1
4CL012-030	DUCT, INLET 08 HEMI CHALLENGER	1	4CL010-160	BRKT, FLDYNE CHALLENGER DR	1
7A250-039	1/4-20 X 3/8" SHCS ZINC PLTD	2	4CL010-170	BRKT, FLDYNE CHALLENGER PA	1
7J250-001	1/4 WASHER, SAE, PLTD	2	8N107-190	WATER PUMP MTG ASSY, 07 CHGR	1
7R002-056	#56 SAE TYPE F SS HOSE CLAMP	1	5W001-011	16-14 GA RING TERM .26" HOLE	1
7R002-080	#80 SAE TYPE F SS HOSE CLAMP	1	5W001-013	14-16 GA BUTT CONN BLU INSUL	2
7S500-351	INLET SLEEVE, HEMI, 5 X 3.5	1	5W001-024	MINI ATC FUSE TAP	1
8H040-235	AIR FILTER, 4" FLG X 7.0L	1	5W001-025	FEMALE SLIDE, INSULATED, MINI	1
7P500-009	1/2"X90 HOSE BARB UNION	1	5W001-054	18 GA FUSE HOLDER	1
7U030-036	1/2" OIL DRAIN HOSE	4'	5W014-030	14GA STRD WIRE BLACK	5
8H040-300	AIR FILTER 300C	1	7R003-027	ADEL CLAMP, 1-11/16"	1
7U032-020	3/8 P/S HOSE	32"	8F001-402	PUMP, WATER, PIERBURG	1
4CL112-084	AIR DISCH ASSY, 11-12 6.4L HEMI	1	8N100-001	NYLON MOUNTING KIT	1
4CL010-270	BRKT, DUCT SUPRT, P. SIDE, 6.4	1	8N201-394	WELDED, CORE ASSEMBLY, HEMI	1
4CL010-300	BRKT, DUCT SUPRT, REAR, 6.4	1	*SEE PAGE VIII FOR INDIVIDUAL COMPONENTS IN ASSEMBLY		
4CL012-074	DISCHARGE DUCT "A" COATED	1			
4CL012-084	DISCHARGE DUCT "B" COATED	1			
4CL012-094	DISCH TUBE "C", 2011-12 6.4L H	1			
7P750-502	REDUCER, 3/4" TO 1/2" COUPLER	1			
7PS275-100	SLEEVE, BLACK, 2.750D X 1.0	1			
7PS275-300	SLEEVE, BLACK, 2.75ID X 3.0	3			
7PS350-277	ELBOW, SIL, 3.5X2.75 90°, BLK	1			
7P375-156	3/8 X 3/8 X 5/32 MALE BARB TEE	1			
7R002-016	#16 SAE TYPE F SS HOSE CLAMP	2			
7R002-044	#44 SAE TYPE F SS HOSE CLAMP	9			
7R002-056	#56 SAE TYPE F SS HOSE CLAMP	1			
7U030-046	5/32" VACUUM LINE	5'			
7U034-016	1" GS HEATER HOSE	.25'			
8D001-004	COMPRESS BYPASS VALVE, G2	1			
8H040-075	FILTER, 1" BYPASS VALVE	1			
5W001-093	HARNESSE EXTENSION, ETC, 2011	1			
8N006-020	WATER COOLR, FLDYN DUAL PASS	1			
8N105-220	WATER TANK ASSY, 2011 6.4 HEMI	1			
4CL010-190	BRKT, CAC TANK, HEMI	1			
7A250-050	1/4-20 X .50 SHCS GR8 ZINC PLT	4			
7A250-051	1/4-20 X .50 HHCS GR5 ZINC PLT	2			
7A250-101	1/4-20 X 1 HHCS ZINC PLTD	1			
7E010-075	#12 X 3/4" SHT METL SCR W HEX	8			
7J250-001	1/4 WASHER, SAE, PLTD	7			
7P375-075	3/4" HOSE BARB UNION, BRASS	5			

This page was left intentionally blank.

1. PREPARATION AND REMOVAL

NOTE: Apply a drop of thread-lock compound to the threads of each fastener prior to installation.

- A. Disconnect negative cable at the battery.
- B. Remove the plastic engine covers and set aside.
- C. Remove the valve cover breather hose from the factory air inlet duct. Remove the air filter and all ducting upstream of the throttle body.
- D. Unplug the IAT (Inlet Air Temperature) sensor connector and remove it from the air filter housing. Set it aside for later use.
- E. Remove the accessory drive belt.
- F. Unplug the fan electrical connector, then remove fan shroud hardware. Pull up and remove the electric radiator fan assembly from the vehicle (cooling system may need to be drained and upper radiator hose removed).
- G. Using an appropriate power steering pulley removal tool, remove the power steering pulley from the pump.
- H. Install the supplied power steering pulley hub onto the power steering pump so that it is flush with the end of the shaft. (See Fig. 1-a)

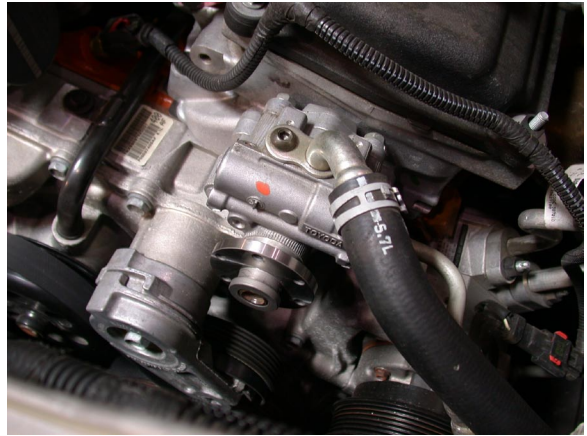

Fig. 1-a (5.7L P/S Pump Shown)

2. FRONT FASCIA REMOVAL

- A. Remove the plastic splash pan on the bottom of the vehicle.
- B. Remove the electrical plug for the fog lights located on the passenger side of the vehicle.
- C. Remove the plastic rivets securing the inner fender liners (new rivets are supplied for re-installation).
- D. Locate the two 10mm headed screws in the front outer edge of the inner fender (one on each side of the vehicle) (See Fig 2-a). Remove the screws and set aside to be reinstalled in a later step.
- E. Locate and remove the four 10 mm nuts (Two on each side of the vehicle) (See Fig. 2-b)
- F. Remove the two covers from the top of the fascia (See Fig. 2-c)
- G. Remove the six plastic retaining clips securing the top of the fascia to the radiator core support.
- H. Gently pull the corners of the fascia way from the fenders. And remove the fascia.
- I. Remove the plastic clips retaining the inner fascia support. And remove the inner fascia support. (See Fig. 2-d, 2-e)
- J. Remove the three 8 mm headed screws from the drivers side headlight.
- K. Pull the headlight straightforward and remove.
- L. Remove the two head light plugs. And set the head light assembly aside.



Fig. 2-a

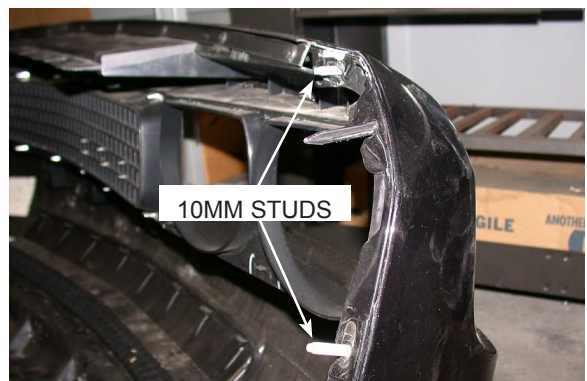

Fig. 2-b



Fig. 2-c



Fig. 2-d

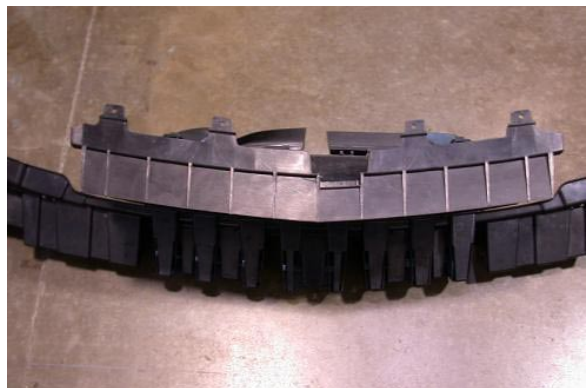

Fig. 2-e

3. HARMONIC DAMPER DOWEL PIN INSTALLATION

NOTE: The purpose of this section is to provide access to the harmonic damper bolt area so that the crankshaft can be pinned to the damper to prevent the damper from spinning on the crankshaft. The following steps will work on all or most applications. If it is not possible to get adequate clearance by performing the following steps, follow the manufacturer's steps for removing the harmonic damper until there is sufficient room to work in.

- A. Remove the crankshaft damper bolt. (A factory tool may be used to keep the engine from rotating or carefully use a pry tool to keep the damper from rotating.)
- B. Install the supplied drill guide with the raised section piloting in the damper bore. Secure in place by installing the supplied socket head cap screw. Do not over-tighten the screw as it may distort the drill guide (its purpose is just to hold the guide in place while drilling). See Fig. 3-a.
- C. Using a small drill motor (right angle pneumatic works well), mark a 1/4" drill bit with electrical tape or a drill stop so that the hole will be deep enough for the supplied 1/2" long dowel pin. See Fig. 3-b.
- D. Drill hole in damper/crankshaft.
- E. Remove the socket head cap screw.
- F. Clean area of metal chips and install the supplied dowel pin in the drilled hole making sure that it does not protrude past the damper face.
- G. Install and tighten the crankshaft damper bolt to 129 ft-lbs (176 Nm).
- H. Re-install the radiator fans and verify that the electrical connector is plugged in.



Fig. 3-a (Supplied Drill Guide Tool)

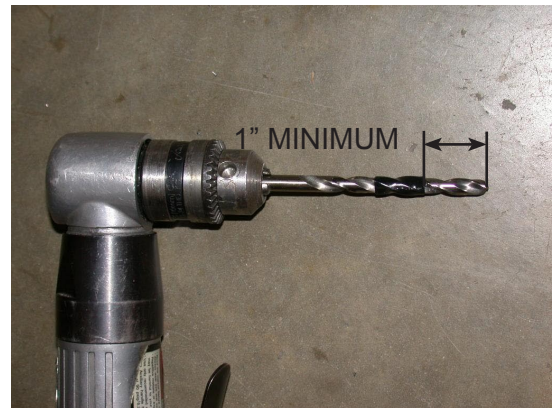

Fig. 3-b

4. COOLANT & POWER STEERING RESERVOIR REPLACEMENT

NOTE: For proper installation, the factory coolant reservoir & power steering fluid reservoir will need to be replaced with the included old-style reservoirs.

- A. If there is still coolant present in the tank, remove the coolant reservoir cap & drain the coolant from the radiator drain port located on the bottom of the radiator. For ease of installation, only drain enough to empty the coolant reservoir. Once drained, remove the factory-installed coolant reservoir & install the supplied coolant reservoir & refill. (See Fig. 4-a)
- B. Remove the power steering fluid reservoir cap & drain the power steering fluid by removing the rubber line directly below the reservoir. Once drained, remove the threaded line from the power steering pump & set aside, then proceed to remove the 3 screws securing the power steering pump to the cylinder head. Additional fittings will be installed in a later step. (See Fig. 4-b)
- C. Locate the supplied power steering fluid reservoir & install it onto the coolant reservoir as shown in Fig. 4-a. Locate the rubber line previously removed from the power steering reservoir & install it onto the supplied power steering fluid reservoir. Using the supplied large-diameter power steering line, attach it to the bottom of the supplied power steering fluid reservoir & set aside. The other end of the large-diameter hose will be installed in a later step. Secure both lines with the supplied hose clamps. (See Fig. 4-c)

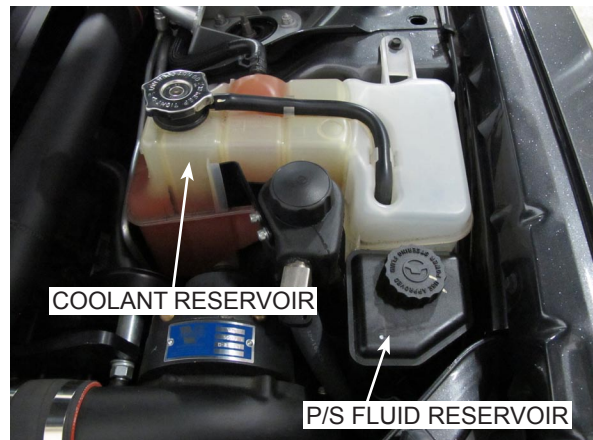

Fig. 4-a (*Supplied Reservoirs*)

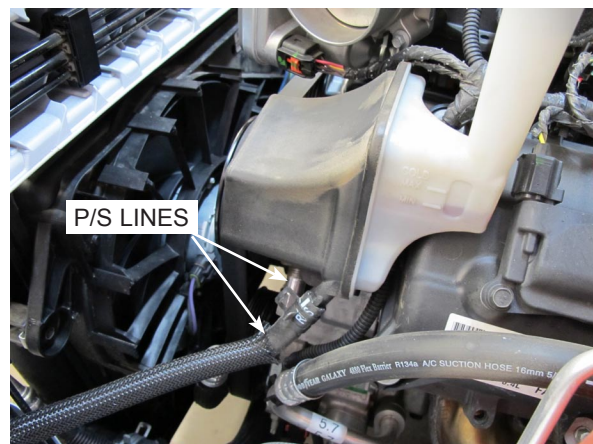

Fig. 4-b

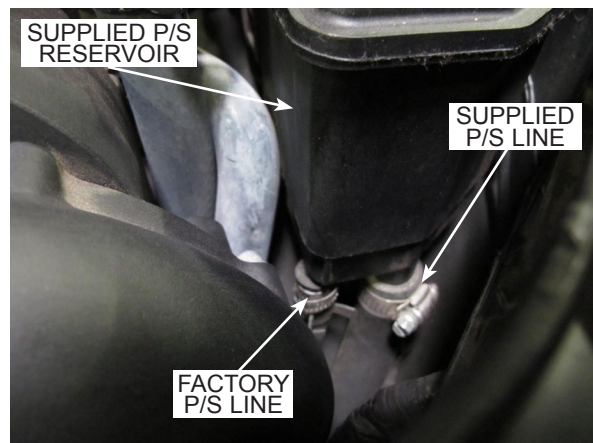

Fig. 4-c

5. SUPERCHARGER MOUNTING PLATE INSTALLATION

- A. There are (3) 10mm headed screws securing the reservoir to the pump. (2) screws are located on the back side of the power steering pump & (1) is located on the pulley-side of the power steering pump (not pictured). Remove these (3) screws, then remove the power steering fluid reservoir from the power steering pump. (See Fig. 5-a)
- B. Carefully remove the o-ring from the previously removed power steering fluid reservoir & transfer it over to the supplied power steering adaptor block. Be sure not to damage the o-ring. (See Fig. 5-b)
- C. Locate the supplied power steering fittings & clock them as shown. Use a light amount of pipe sealant on the threads. (See Fig. 5-c)
- D. Locate the supplied mounting bracket assembly. Loosely attach the steel bracket to the back of the primary mounting plate. Attach the supercharger mounting plate to the primary mounting plate using the supplied M8x90mm bolts and spacers. (See Fig. 5-d)

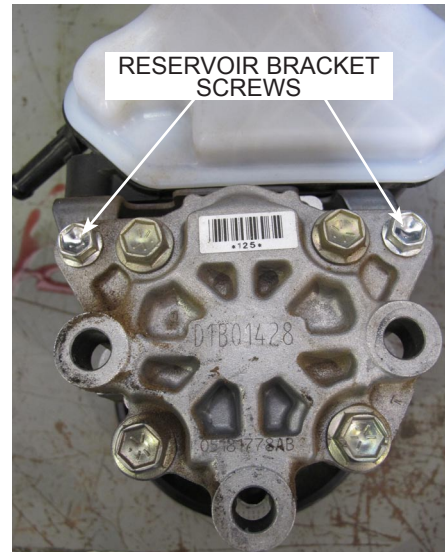

Fig. 5-a

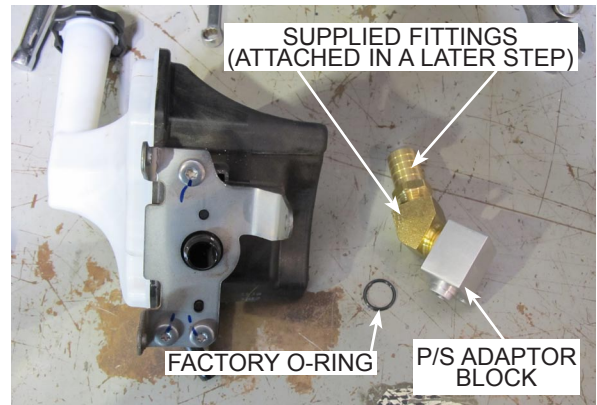

Fig. 5-b

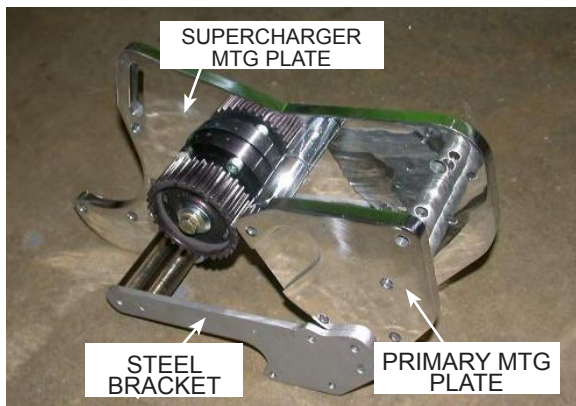

Fig. 5-d

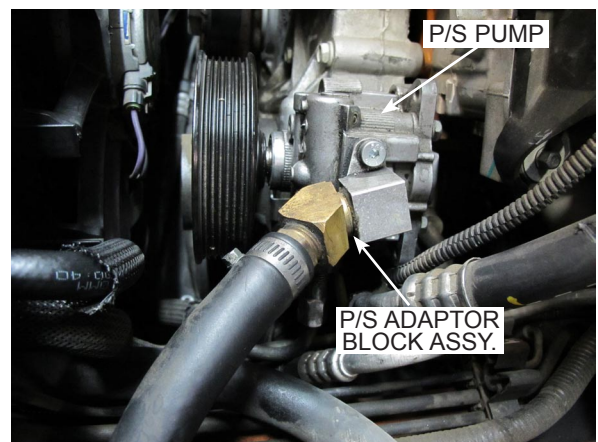

Fig. 5-c (Clocking Reference)

5. SUPERCHARGER MOUNTING PLATE INSTALLATION, CONT'D

- E. Sandwich the power steering pump between the steel plate and the supercharger mounting plate, making sure to install the (2) supplied power steering pump spacers (one pictured). Secure the power steering pump to the bracket using the (3) supplied screws & washers. At this point, tighten the two screws attaching the steel bracket to the primary mounting plate. (Loosely installed in Step D.) (See Fig. 5-e)
- F. Using the supplied allen-head screw, install the power steering adaptor block & fittings to the power steering pump at this time, making sure not to pinch or damage the o-ring. You may need to make adjustments to the fittings for proper clearance. (See Fig. 5-f)
- G. Use Fig. 5-g as a visual representation of how the power steering pump adaptors are supposed to be clocked once installed on the bracket. Adjust as necessary.

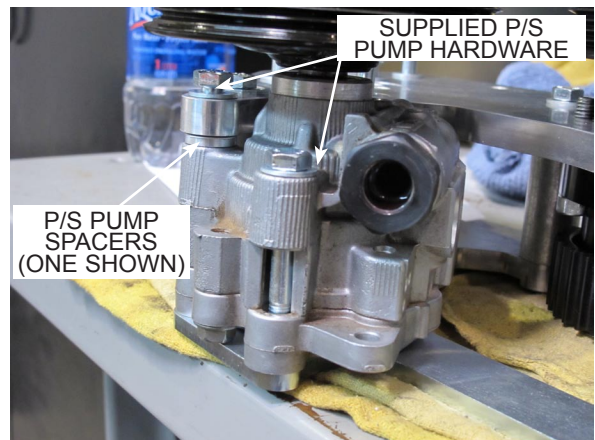

Fig. 5-e



Fig. 5-f



Fig. 5-g

5. SUPERCHARGER MOUNTING PLATE INSTALLATION, CONT'D

NOTE: Steps H, I, J apply to Challenger M6 only. All others, skip to Step K.

- H. **Challenger M6 Only:** Remove power steering hose from pump to reservoir. Cut hose as depicted in Fig. 5-h Set aside the two longer pieces of hose and discard the two shorter pieces. Replace the small bend with a $\frac{3}{4}$ hose union and attach the 2 pieces of hose together.
- I. **Challenger M6 Only:** Install the hose so that the end with the single bend attaches to the pump. Do not install clamps. Mark union for correct clocking. Remove the hose from the car and install stepless clamps at union. (See Fig. 5-i)
- J. **Challenger M6 Only:** Install hose assembly back into car using the factory clamp to secure the hose to the reservoir and a supplied hose clamp to attach the hose to the power steering pump. (See Fig. 5-j)
- K. Start the supplied 8mm bolt in the outside hole making sure that it does not protrude through the back and impact the a/c line. See Fig. 5-k.
- L. Install a .475" spacer between the supercharger mounting plate and the power steering pump at the two remaining power steering pump mounting holes. Install 8mm x 90mm bolts and washers.
- M. Position the supercharger mounting plate assembly in front of the engine and secure it to the head using the three M8 x 100 mm bolts and one M8 x 120mm bolt. (See Fig. 5-l).
- N. Tighten all of the mounting plate bolts in steps so that the protruding bolt heads do not hit the power steering pump pulley.
- O. Reattach the threaded power steering line to the power steering pump. Attach the large-diameter power steering line from the previously installed reservoir to the fittings installed onto the power steering pump. Once all the lines are secured, fill the power steering fluid reservoir with power steering fluid & verify that there are no leaks.



Fig. 5-h (Challenger M6)



Fig. 5-i (Challenger M6)

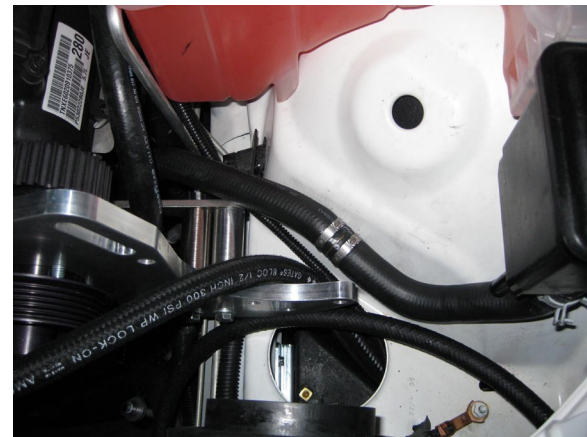

Fig. 5-j (Challenger M6)



Fig. 5-l

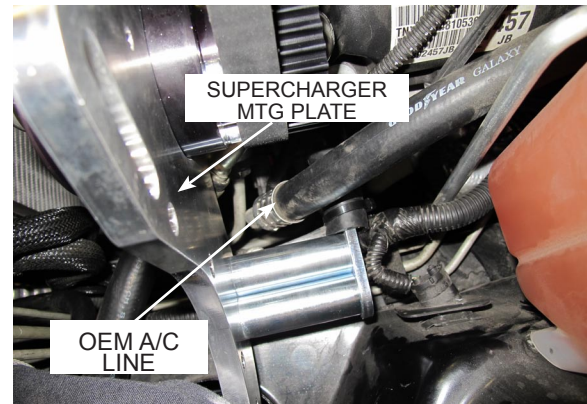

Fig. 5-k

6. SUPERCHARGER INSTALLATION

- A. Install the supplied 3" aluminum idler using the top most 3/8-16 hole on the mounting plate for the idler pulley. Make sure that the snap ring side is facing forward (away from the mounting plate). (See Fig. 6-a).
- B. Install the supplied power steering pump pulley on the already installed hub using the supplied 1/4" hardware.
- C. Install the supplied accessory drive belt as shown in Fig. 6-b).
- D. Position the supercharger in front of the mounting plate assembly in front of the engine and install and tighten the four 3/8" x 1 1/4" bolts.
- E. Install the supplied cog belt around the pulleys on the mounting plate assembly.
- F. Using the supplied M12 x 100mm bolt, install the supplied 3.5" aluminum idler with the bearing retaining snap ring pointed towards the front of the vehicle. The screw should pass through a flat washer, S/C mounting plate, 1.55" idler spacer, the idler, thick bearing washer, lock washer and nut. Install the supplied nut and lock washer on the end of the screw and tighten the idler so that the gilmer belt is snug. (See Fig. 6-c).
- G. Secure the remote drain hose away from the belt and hoses using tie-wraps.

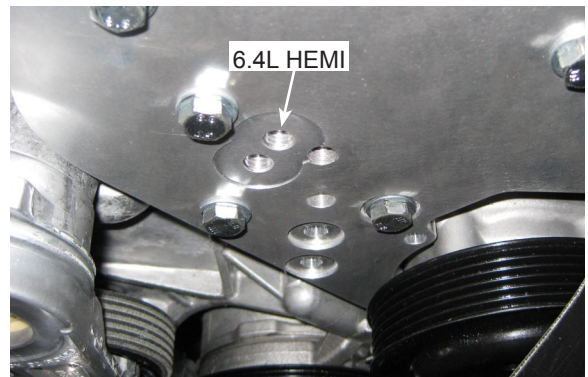

Fig. 6-a

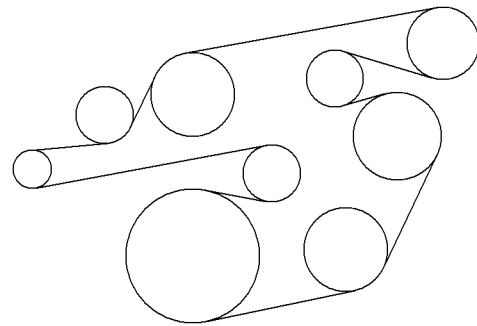

Fig. 6-b

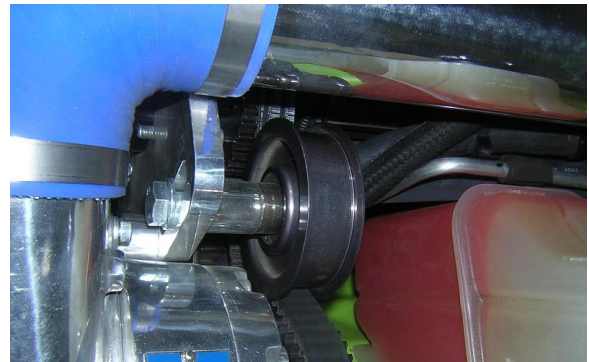

Fig. 6-c

7. AIR INLET INSTALLATION

- A. Locate assembly (4CL112-030) & insure that all parts are present.
- B. Attach the rubber sleeve to the plastic duct with the hose claps provided.
- C. Attach the air filter to the inlet duct. (See Fig 7-a)
- D. Attach the mounting bracket to the duct with the fasteners provided. (See Fig 7-b)
- E. Remove the 15 mm headed bolt at the bottom of the core support. Set the bolt aside to be reinstalled in a later step (See Fig 7-c)



Fig. 7-a



Fig. 7-b



Fig. 7-c

7. AIR INLET INSTALLATION, CONT'D

- F. Remove the hood latch cable clip and move to the side to be reattached to the inlet duct-mounting bracket in a later step.
- G. Remove the 3/8" power steering hose from the drivers side of power steering cooler and from the reservoir. Set aside; it will not be used.
- H. Locate the 30-inch piece of power steering hose that is provided. Install the hose clamps from the factor power steering hose.
- I. Route the new power steering hose down and behind the core support between the radiator and the core support. (See Fig 7-d)
- J. Attach the inlet duct to the inlet of the super-charger and secure with the hose clamp previously installed.
- K. Reinstall the 15 mm headed bolt removed in an earlier step. Attach the hood latch cable to the bracket supporting the inlet duct. (See Fig 7-e)
- L. Attach the crank case breather hose to the 90° plastic fitting on the end of the air filter. (See Fig 7-f)
- M. Route the breather hose through the round hole located in the inner fender to the crank case breather fitting on the intake manifold.
- N. Check the power steering fluid level and re-fill as necessary.
- O. Re-install headlight, hardware and connectors.



Fig. 7-d



Fig. 7-e



Fig. 7-f

8. CHARGE AIR COOLER/DISCHARGE ASSEMBLY INSTALLATION

- A. Cut the brake booster line attached to the brake booster and install the supplied brass tee. This tee will be used by the bypass valve for vacuum source. Use the supplied stepless clamps to secure the brass tee to the brake booster line. (See Fig. 8-a)
- B. Near the back of the engine on the drivers side, you will see a stud sticking out with a ground strap attached to it. Remove the nut securing the ground strap to the stud, slide on the supplied discharge tube support bracket & reinstall the nut. The bracket is slotted, so you may need to adjust the bracket for proper fitment.(See Fig. 8-b)
- C. Remove the upper alternator screw & discard. It will not be reused. Install the supplied screw into the upper alternator mount. Be sure to use the provided washers.
- D. Once the supplied screw is in place, slide on the supplied .155" spacer & thread on the provided nut & washer by hand. Do not tighten all the way. (See Fig. 8-c)
- E. Using a 15mm socket, remove the screw to the left of the throttle body, directly above the thermostat housing. Set screw aside as it will be reused.
- F. Locate supplied charge air cooler support. Notice the bottom of the charge air cooler support is slotted (See Fig. 8-d). Slide the slotted section of the charge air cooler support in between the .155" spacer & washer closest to the nut previously installed. Once the slotted section of the charge air cooler support is in place, locate the 15mm screw previously removed & install through the upper tab of the charge air cooler support, threading the screw back into its original location. (See Fig. 8-e)
- G. Tighten the 15mm screw & upper alternator mount hardware. Place the charge air cooler on top of the charge air cooler support.



Fig. 8-a

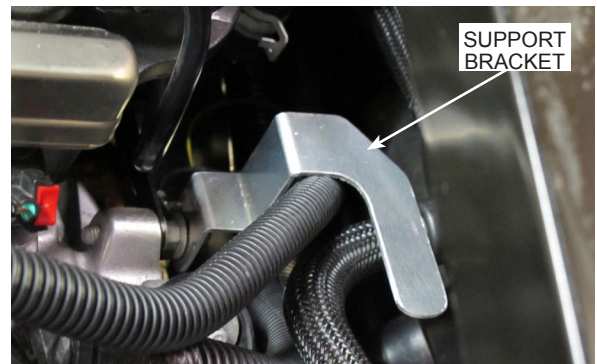

Fig. 8-b

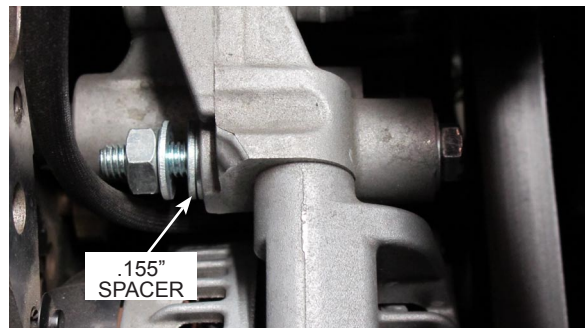

Fig. 8-c



Fig. 8-e (CAC Support Bracket, Installed)



Fig. 8-d (CAC Support Bracket)

8. CHARGE AIR COOLER/DISCHARGE ASSEMBLY INSTALLATION, CONT'D

NOTE: As tube adjustment will be necessary, leave all hose clamps loose until Step R.

- H. (See “Discharge Tube Identification” below). Locate discharge tube B & install the supplied silicone sleeve onto the shorter leg of the tube with the 45° bends. Place hose clamps hand tight onto the sleeve but do not tighten all the way.
- I. On the shorter leg of discharge tube B, position the hose clamps so they are pushed slightly towards the back. This is in preparation for a later step. (See Fig. 8-f)
- J. Slide a silicone coupler onto the long leg of discharge tube B, then slide the tube onto the charge air cooler. Make sure discharge tube B is resting on the discharge tube support bracket on the passenger side. This will leave the other end of the tube near the back of the engine, close to the firewall.
- K. Locate discharge tube C & install the factory IAT sensor using the supplied rubber grommet. (See Fig. 8-g)
- L. Install the supplied 90 degree silicone elbow onto the throttle body.
- M. Locate discharge tube C & place the tube so that the section with the two bends are near the back of the engine, close to the firewall. Slide discharge tube C into the silicone coupler previously installed onto discharge tube B (See Fig. 8-h). Insert the other end of discharge tube C into the 90° silicone elbow previously installed on the throttle body.
- N. Locate the supplied 1” silicone coupler & cut it so it can be placed around discharge tube C. Place the cut coupler around discharge tube C & position it in a way to trap the drivers side discharge tube support bracket between the coupler & discharge tube C. Place supplied hose clamp over the coupler. (See Fig. 8-i)



Fig. 8-f (Tube B)

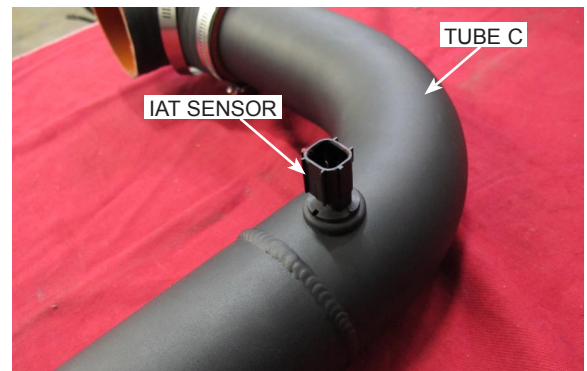

Fig. 8-g (Tube C)

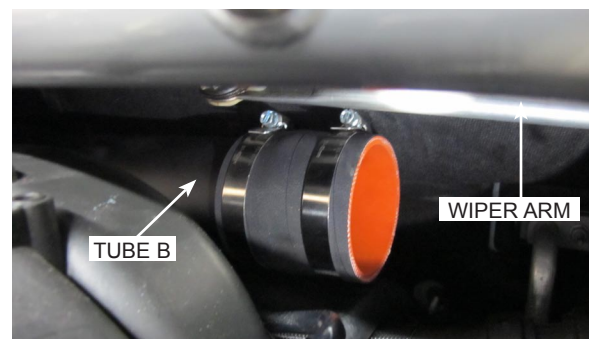
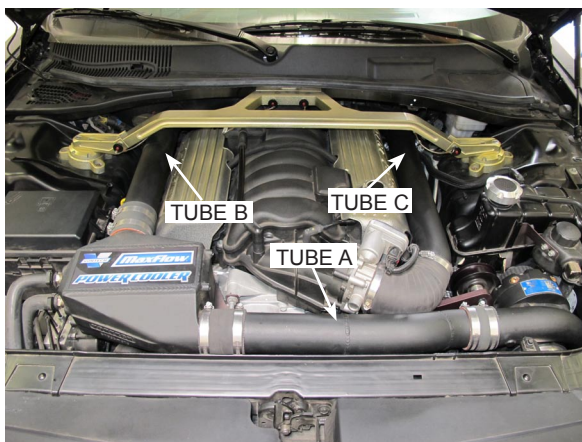

Fig. 8-h



Discharge Tube Identification

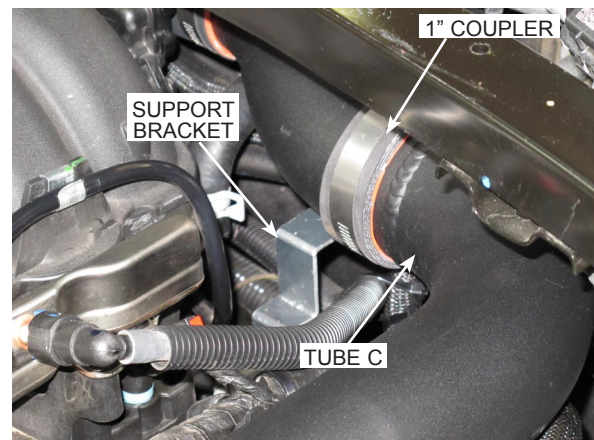

Fig. 8-i

8. CHARGE AIR COOLER/DISCHARGE ASSEMBLY INSTALLATION, CONT'D

- O. Reconnect the IAT Sensor plug to the IAT sensor, making sure the wire is clear of the cog belt. (See Fig. 8-j)
- P. Locate discharge tube A. Install the supplied bypass valve & filter onto the welded barb using the supplied 1" hose. Connect the supplied 5/32" vacuum hose to the bypass valve & route under the throttle body, across the driver's side of the engine, connecting the other end of the vacuum hose to the previously installed vacuum tee on the brake booster line. Use zip ties to secure the vacuum hose to the fuel injector harness.
- Q. Place discharge tube A in between the charge air cooler & supercharger outlet using the supplied silicone couplers & hose clamps. The end of the tube with the bends will go towards the supercharger outlet. Be sure that the bypass valve is pointing straight down towards the bottom of the vehicle, making sure that the bypass valve & filter are clear of the accessory drive pulleys & belt.

NOTE: To keep the vacuum hose from rubbing against the accessory drive belt, we suggest using zip ties to hold the vacuum hose against the 1" bypass valve hose. (See Fig. 8-k)

- R. Verify that all of the discharge tubes are in place & proceed to tighten all of the hose clamps. Make any necessary adjustments to the tubes or support brackets for proper fitment. The hose clamps on the silicone coupler joining discharge tube B & discharge tube C must be tightened using an 8mm socket, swivel joint & a long extension. The hose clamps must be pushed towards the firewall to make clearance for the windshield wiper arms. Failure to do so will result in the windshield wiper arms coming into contact with the hose clamps.
- S. Locate the engine covers & modify them so they clear discharge tubes "B" & "C". (See Figs. 8-l, 8-m, 8-n)

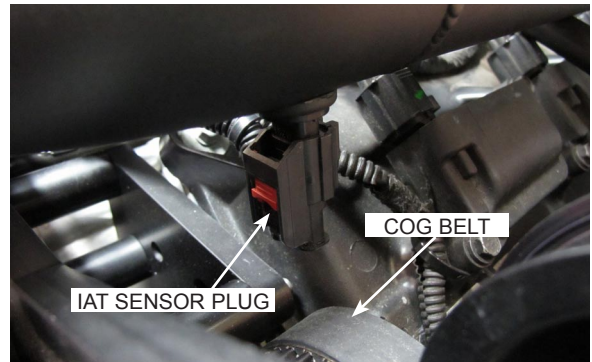

Fig. 8-j

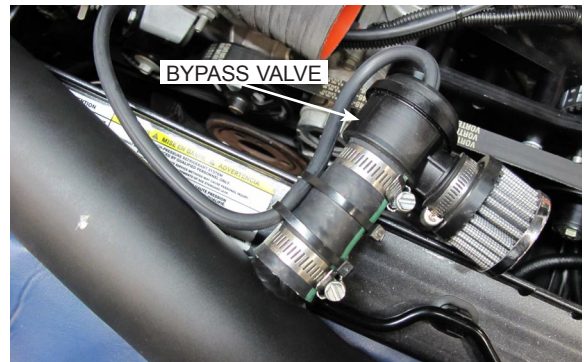

Fig. 8-k

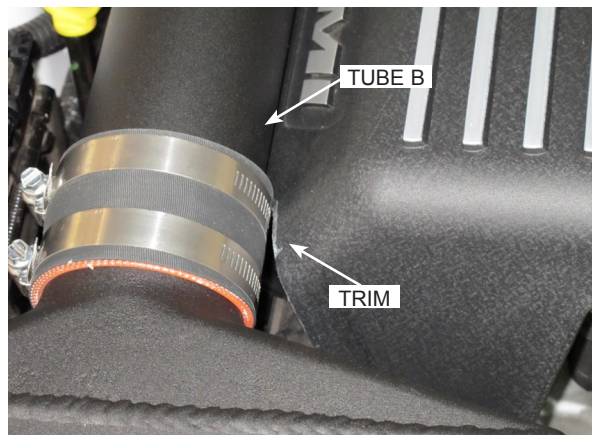

Fig. 8-l (Passenger Side)

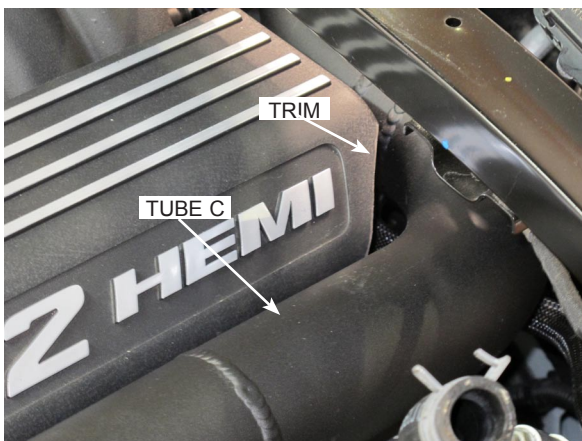

Fig. 8-n (Drivers Side)

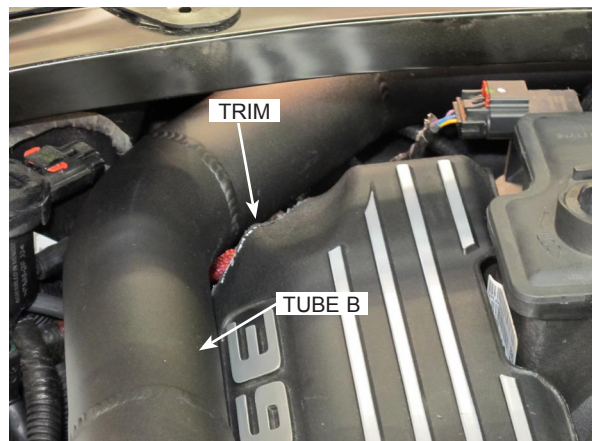

Fig. 8-m (Passenger Side)

9. RESERVOIR AND WATER PUMP ASSEMBLY AND INSTALLATION

- A. Attach the surge tank bracket to the surge tank using 1/4-20 x .5" cap screws. Mount the surge tank bracket to the slot in the factory coolant reservoir. (See Fig. 9-a)
- B. In the area in front of the drivers side front wheel, position the water reservoir/bracket next to the frame rail. Orient the assembly for the best clearance, at least 6" from the rear face of the bumper. (See Fig. 9-b)
- C. Mark the mounting bracket location and remove. Drill two 11/64" holes for the supplied #12 sheet metal screws.
- D. Using thread sealant, install the 1/2" NPT 90° hose barb fitting into the top and bottom of the supplied plastic reservoir.
- E. Secure the assembly to the frame rail using two #12 sheet metal screws. (See Fig. 9-c)
- F. Trial fit the front bumper cover to verify water reservoir clearance.
- G. Cut off the electrical plug on the water pump leaving as much wire connected to the pump as possible. Install the supplied 1/4" eyelet onto the water pump ground wire (brown wire).
- H. Connect the pump inlet to the bottom reservoir fitting with a piece of supplied hose. Point the pump to discharge forward (and slightly up, to allow air to escape the pump housing). Secure the hose with the nylon ratchet clamps on both ends. Drill a hole in the radiator support and secure the water pump to it using an adel clamp and #12 sheet metal screw. Make sure to ground the water pump under the mounting screw. (See Fig. 9-d)
- I. Connect a 90° molded hose to the barbed fitting on top of the reservoir & secure with a nylon ratchet clamp (short leg of the hose gets attached to the reservoir). Locate the supplied 3/4" hose & connect it to the 90° molded hose using a hose mender & nylon ratchet clamps. Run the hose up to the area next to the drivers side valve cover, routing the hose behind the drivers side headlight. Attach the 3/4" hose to the lower barbed fitting of the surge tank & secure with a nylon ratchet clamp (cut the hose to the appropriate length).
- J. Drill a 5/8" hole in the rear facing side of the power distribution box lid approx. 3" from the inner edge. Insert the supplied grommet into the hole. Install the supplied fuse holder from the inside of the lid, pressing one end into the grommet. Connect the fuse tap and slide connector to the fuel pump fuse (refer to owners manual for fuel pump fuse). Connect the remaining end of the fuse holder to the water pump wire using the supplied wire. Route the wire behind the engine, following the factory loom. Install the supplied split loom over the wire. (See Fig. 9-e)



Fig. 9-a (Surge Tank)



Fig. 9-b



Fig. 9-c

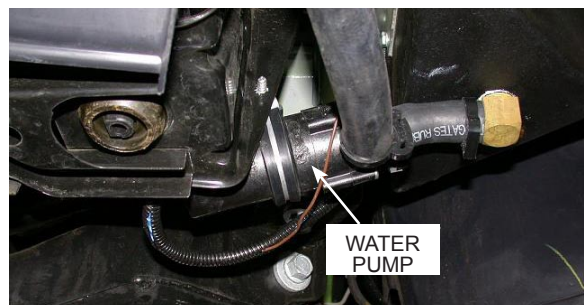

Fig. 9-d (Water Pump)

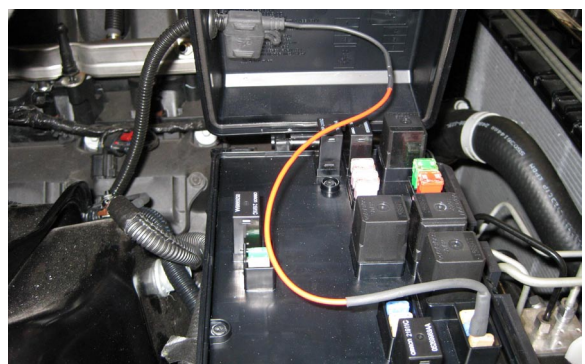

Fig. 9-e

10. CHARGE AIR COOLER RADIATOR INSTALLATION

- A. Attach the supplied brackets to each side of the CAC radiator as shown in Figs. 10-a and 10-b. Remove the 8mm screws from the A/C condenser & install the CAC radiator to the condenser. Remove the two small plastic panels from the front bumper cover as shown in Fig. 10-c.
- B. Connect the water pump discharge to the bottom hose barb on the CAC radiator using the supplied 90° molded hose (and additional 3/4" hose if needed). See Fig. 10-f (on the next page) for CAC hose routing.
- C. Attach two 90° molded hoses to the CAC core & secure them with nylon ratchet clamps. Point the two hoses towards the front of the vehicle. (See Fig. 10-d)
- D. Locate the 3/4" x 150° molded hose & attach it to the upper hose barb on the CAC radiator. Connect the other end of the 3/4" x 150° hose to the 90° molded hose on the water inlet fitting (upper fitting) on the CAC core using the supplied hose menders & 3/4" hose (cut hose to the appropriate length). Secure using nylon ratchet clamps. Run the hose along the top of the bumper beam. (See Fig. 10-e)
- E. Using a hose mender, attach the 3/4" hose to the remaining 90° molded hose on the CAC core. Run the 3/4" hose parallel to the previously installed hose, routing the end of the hose behind the drivers side headlight, up towards the drivers side valve cover. Attach the other end of the 3/4" hose to the upper fitting of the previously installed surge tank & secure with nylon ratchet clamps. Use zip ties to secure the two hoses running along the top of the bumper beam.
- F. Remove cap from surge tank and slowly fill system with 25%/75% coolant/water mix. Check for leaks.
- G. Re-install the front inner and outer fascias and fender liner in reverse of removal.

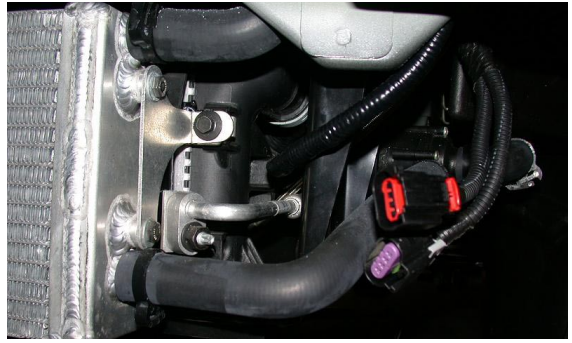

Fig. 10-a

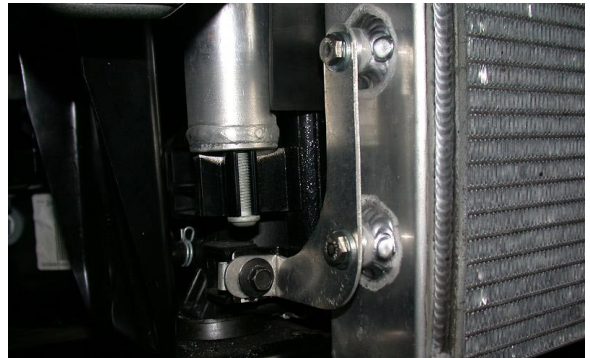

Fig. 10-b



Fig. 10-c



Fig. 10-e

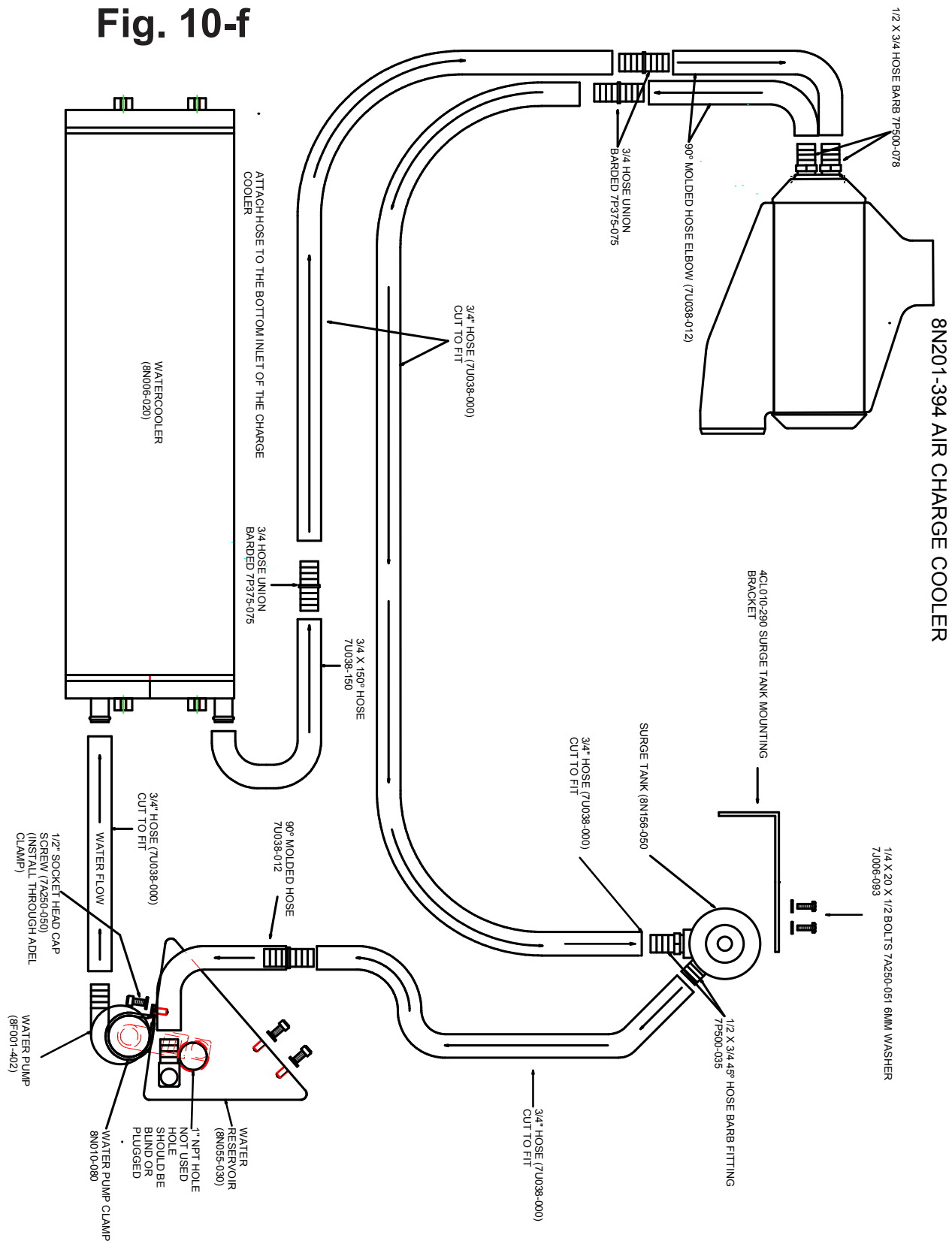

Fig. 10-d

10. CHARGE AIR COOLER RADIATOR INSTALLATION, CONT'D

CAC HOSE ROUTING

Fig. 10-f



11. FINAL ASSEMBLY AND CHECKING

NOTE: THIS SUPERCHARGER HAS BEEN FACTORY PRE-FILLED WITH SPECIAL SYNTHETIC LUBRICANT. OIL DOES NOT NEED TO BE ADDED TO A BRAND NEW UNIT. HOWEVER THE FOLLOWING FLUID LEVEL CHECK SHOULD BE PERFORMED.

- A. Remove the factory installed flat head brass shipping plug (not the dipstick) from the top of the supercharger case.
- B. Replace the sealed shipping plug with the supplied "vented" plug. Do not operate the supercharger without it.
- C. Ensure that the .06" copper sealing washer is located on the dipstick base.
- D. Thread the clean dipstick into the supercharger until it seats.
- E. Once the dipstick has seated, remove the dipstick from the unit. Fluid should register in the crosshatched area on the dipstick.
- F. **DO NOT OVERFILL!!** Drain excess fluid from the unit if it is above the maximum level on the dipstick. Install and tighten the dipstick in the gearcase.
- G. If your vehicle has gone over 20,000 miles since its last spark plug change, it is a good idea to change the spark plugs now, before test-driving.
- H. Make sure that the vehicle is filled with 91 octane or higher fuel before commencing test drive.
- I. With key on, make sure charge air cooler water pump is operating and that water is flowing through the surge tank. Fill as necessary. If water is not flowing, remove the hose from the bottom of the surge tank and lower until water flows out of hose. This should prime the pump. Reconnect hose, verify water flow and top off surge tank. Do not run the water pump for extended periods (30 seconds or more) without water flow.
- J. Check all fittings, nuts, bolt and clamps for tightness.
- K. At this point it is OK to start the vehicle.

WARNING: DO NOT ATTEMPT TO OPERATE THE VEHICLE UNTIL ALL COMPONENTS ARE INSTALLED AND ALL OPERATIONS ARE COMPLETED INCLUDING FINAL CHECK. FAILURE TO DO SO MAY CAUSE PREMATURE FAILURE OF MAJOR COMPONENTS.

- L. With engine running, check power steering hose connections for leakage. Let engine run for two minutes. Turn steering wheel in both directions.



Fig. 11-a

11. FINAL ASSEMBLY AND CHECKING, CONT'D

Verify:

- Smooth power assist
 - Noiseless operation
 - Proper fluid level
 - No system leaks
 - No bubbles, foam or discoloration in fluid
- M. Verify that the cog belt is running smoothly. If wear is detected on the side of the belt, it is probably too tight. If it is vibrating excessively, tighten until there is minimal movement.
- N. Turn off vehicle and recheck all fluid levels and verify that no hoses, wires, etc. are near exhaust headers or moving parts and that there is no fluid leakage.
- O. Re-install the splash pan.
- P. Test drive vehicle by gradually working up to full throttle and paying close attention to any abnormal sounds or engine detonation.
- Q. Install the engines cover by trimming as necessary to clear the supercharger kit.
- R. Read the STREET SUPERCHARGER SYSTEM OWNER'S MANUAL AND RETURN THE WARRANTY REGISTRATION FORM within thirty (30) days of purchasing your supercharger system to qualify for the 3 year limited warranty.

WARNING: NEVER OPERATE YOUR ENGINE AT FULL THROTTLE WHEN THE ENGINE IS COLD. ALWAYS ALLOW PLENTY OF TIME FOR THE OIL TO REACH FULL OPERATING TEMPERATURE BEFORE RUNNING ABOVE 2,500 RPM. FULL SUPERCHARGER OPERATING TEMPERATURE IS GENERALLY ACHIEVED ONLY AFTER THE ENGINE WATER TEMPERATURE HAS BEEN AT THE NORMAL INDICATED OPERATING RANGE FOR TWO OR THREE MINUTES.

V3 supercharger long term maintenance and care:

- **CAUTION:** Use of any fluid other than the Vortech supplied synthetic lubricating fluid will void the warranty and may cause component failure.

Replacement Vortech SL lubricating fluid part numbers:

009035: Package of three 4 oz. bottles

- Check the fluid level using the dipstick at least every 2,500 miles.
 - Initial supercharger fluid change must be performed at 2,500 miles. The supercharger fluid must then be changed at least every 7,500 miles.
1. Drain the fluid, re-fill the unit only with 4 oz. of Vortech supplied synthetic lubricating fluid.
 2. Confirm proper oil level using the dipstick. **DO NOT OVERFILL!!**

This page was left intentionally blank.



ENGINEERING, INC

1650 PACIFIC AVENUE • CHANNEL ISLANDS, CA 93033-9901 • (805) 247-0226
FAX (805) 247-0669 • www.vortechsuperchargers.com • M-F 7:00 AM - 3:30 PM PST