



ELECTRONIC FUEL INJECTION

Pro Dash Standalone Quick Start Guide



CONTENTS:

Introduction.....	3
Package Contents	3
Dash Mounting	3
Connections	4
Main Harness	4
Vehicle Speed - GPS Antenna.....	5
USB.....	5
Touchscreen Basics	6
Cleaning	6
Main Menu.....	7
Standalone Setup	7

ATTENTION!

A FULL SET OF MANUALS FOR THE PRO DASHES CAN BE DOWNLOADED AT
https://www.holley.com/support/resources/#Fuel_Injection

Introduction

The 553-116 (12.3") and 553-117 (6.86") Standalone Pro Dash products are suitable for street and racing applications to monitor and record standard engine functions, as well as allowing the addition of a variety of other sensors. This Quick Start Guide provides a very basic overview on installing the semi-terminated harness, and using the preconfigured screen layouts. The connection and wiring of additional sensors, as well as the setup and detailed instructions of the Holley Pro Dash, can be found in additional manuals downloaded at https://www.holley.com/support/resources/#Fuel_Injection

Package Contents



Item	Description
1	Dash
2	Main Harness
3	IO#1 Harness
4	IO#2 Harness
5	GPS Antenna
6	USB Cable
7	4 Foot Male/Female CAN Cable
8	CAN Terminator
9	Mounting Hardware, Template, Cleaning Cloth
10	USB Stick

NOTE: Sensors are not included in these kits and must be purchased separately. See information below.

Dash Mounting

There are two basic ways to mount the Pro Dash, "surface" or "flush" mount. Please consult the Pro Dash User Manual for detailed instruction on each mounting method. There is also a 1:1 printed template included with your Pro Dash, which may be used to mark the necessary mounting holes, etc.

Connections

Main Harness

The “Main Harness” consists of a 34 pin connector which plugs into the back of the dash, various loose wires, two metripak connectors, several sensor connectors, and a CAN connector. The following information covers what is necessary for the operation and functions of the pre-configured dash layouts.

NOTE: Diagrams for the harnesses are at the end of this manual.

Required Connections

NOTE:

- “Loose” refers to an individual wire that is not terminated into a connector
 - “Clean” = a connection that does not share the same connections as “dirty” sources such as coils, a starter, solenoids, fans, etc., that have a lot of electrical noise or solenoid fly-back voltage.
-
- **Loose Black** – Connect to a “clean” ground source. Do not connect to poor ground sources, such as sheet metal, or a ground point that does not have solid connectivity back to the battery.
 - **Loose White** – Connect to a “clean”, switched battery power source such as a fuse panel or relay. This NEEDS to turn on and off, with the ignition or other driver controlled switch, for the dash to operate properly.
 - **Loose Red** – Connect to a “clean” continuous battery power source. Continuous power is needed for a faster GPS lock and to keep the current date and time.

Terminated Sensor Connectors

NOTE:

- The following are pre-terminated sensor connections identified by a label on the harness. They will plug directly into the sensors mentioned, and are pre-configured in the dash layouts. If different sensors are used they must be set up in the dash configuration:
-
- **Oil** – Oil pressure. Use Holley part number 554-102, 100 PSI pressure transducer (1/8” NPT threads)
 - **Pressure** – Fuel pressure. Use Holley part number 554-102, 100 PSI pressure transducer (1/8” NPT threads)
 - **CTS** – Engine coolant temperature. Use Holley part number 534-10, or 543-120 sensor. (3/8” NPT threads)
 - **MAT** – Manifold air temperature. Use Holley part number 534-20 sensor. (3/8” NPT threads). This can be installed in the intake manifold runner or in the air cleaner/engine compartment.

Metripak Connectors

The harness contains 8 and 10 pin Metripak Connectors with loose lead connections on the mating connector; they are labeled as I/O #1 and I/O #2. Consult the main Pro Dash Manuals and the Pro Dash Wiring and Sensor Setup manual on wiring and configuring additional inputs and outputs.

- **I/O #1** – Consists of four switched ground inputs and four 1.5 amp ground outputs. They are not configured for anything specific in the base layouts.
- **I/O #2** – Consists of ten inputs that are configurable for a variety of sensor input types. The table below shows how several are preconfigured for the base dash layouts:

I/O Number	Metripak Pin	Wire Color	Function	Connection Information
IO.3	B	White/Black	Boost	This input is configured as a 3.5 Bar MAP sensor on the base screens (Holley PN 554-134). There is not a terminated connector for it, PN 554-134 includes a pigtail. The input can be configured for any MAP sensor.
IO.8	D	White/Violet	Hi Beam Indicator	This should be connected to a 12v source that is active when the high beam lights are switch on.
IO.10	F	White/Gray	Right Turn Indicator	This should be connected to the 12v output to the right turn indicator.
IO.12	G	White/Yellow	Left Turn Indicator	This should be connected to the 12v output to the left turn indicator.

Loose Wires

- **Engine RPM Input** – The “Spd.1” input is a Light Green wire coming directly out of the dash connector. This should **NEVER** be connected directly to an ignition coil, or any other high voltage source. Any connection other than a dedicated 5volt or 12volt Tachometer (square wave) type output will permanently damage the Pro Dash. If a dedicated Tach output, such as those found on the MSD ignition boxes “Tach out”, is not available, MSD part number 8918 should be purchased. This is attached directly to the coil and conditions the signal for the dash. This should work with MOST factory inductive coil ignitions. The dash is preconfigured for an 8 cylinder engine. For other engine cylinder configurations, refer to the Pro Dash User Manual.
- **Fuel Level Input** – The “IO.7” input is a Gray wire coming directly out of the dash connector. It is preconfigured for a 0-90 Ohm fuel level sending unit. Some preconfigured screens have this shown and some do not. It can be added or deleted as desired, consult the Pro Dash User Manual for the correct procedure.
- **“Spd.2” input** – The “Spd.2” input is a Light Blue wire coming directly out of the dash connector. This is a second “speed” input. It can be configured as a drive shaft speed input for an example. Refer to the Pro Dash User Manual for configuring this input.

CAN Cable

There is a 4-pin male and 4-pin female connector which can be used to connect external CAN devices such as a Holley EFI EGT module. Unless you are using one of these devices, or are connected to an ECU and not using standalone mode, these connectors are not used. The kit includes a CAN terminator. This isn't required unless you have an external CAN device (or connected to an ECU). Plug this in so it isn't lost.

Vehicle Speed - GPS Antenna

The external GPS antenna (included) is used to receive a GPS signal for vehicle speed. All of the base dash screens are configured to use this input for vehicle speed. Install the GPS antenna where it has clear view of the sky to the horizon for best reception. The label needs to face down, with the black plastic part of the antenna facing up. The antenna comes with a built-in magnet and can also be permanently mounted. For racing applications, it is recommended that the antenna be permanently mounted using the included double-sided VHB tape.

Connect the GPS SMA connector to the GPS antenna connector on the back of the unit. Do not overtighten the connector, 3-5 in lbs max.

USB

The unit has two standard USB type C locking receptacles (USB 2.0). Connect the supplied locking cable to either of the USB ports on the back of the unit and tighten the thumbscrews if you will need use of the USB ports.

This cable provides a type 'A' receptacle that can accept USB flash drives for saving data logs, uploading gauge screen layouts, background images, or firmware updates. You may also use these to connect to a USB mouse or keyboard if you do not want to use the integrated touchscreen for configuration.

It is recommended to tape over any unused ports if used in a dusty environment to keep the port clean.

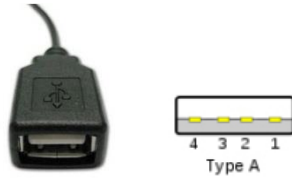

Touchscreen Basics

The Pro Dash has a capacitive touch screen display similar to many cell phones and does not require a stylus. While thick gloves may not work properly, some gloves are available with integrated finger pads that work with touch screens. A stylus may be useful and may be purchased separately from an electronics retailer, if desired. If a stylus is used, ensure it is compatible with a capacitive type touch screen.

Touching anywhere on the screen brings up the ability to datalog (Record). Scroll dash layouts (Prev and Next) (you can also swipe the screen for this), and Menu to bring up the main menu.

Cleaning

If screen needs cleaning, use the supplied microfiber cleaning cloth. Do not use harsh chemical cleaners on the touch screen display.

Do not subject the display to a high pressure water stream from a pressure washer.

Main Menu

Pressing anywhere on a gauge screen will bring up the navigational buttons. To access the main menu choose 'Menu' in the upper right corner of the screen. There is an expansive amount of options available in these areas. Consult the Pro Dash User Manual for detailed information.

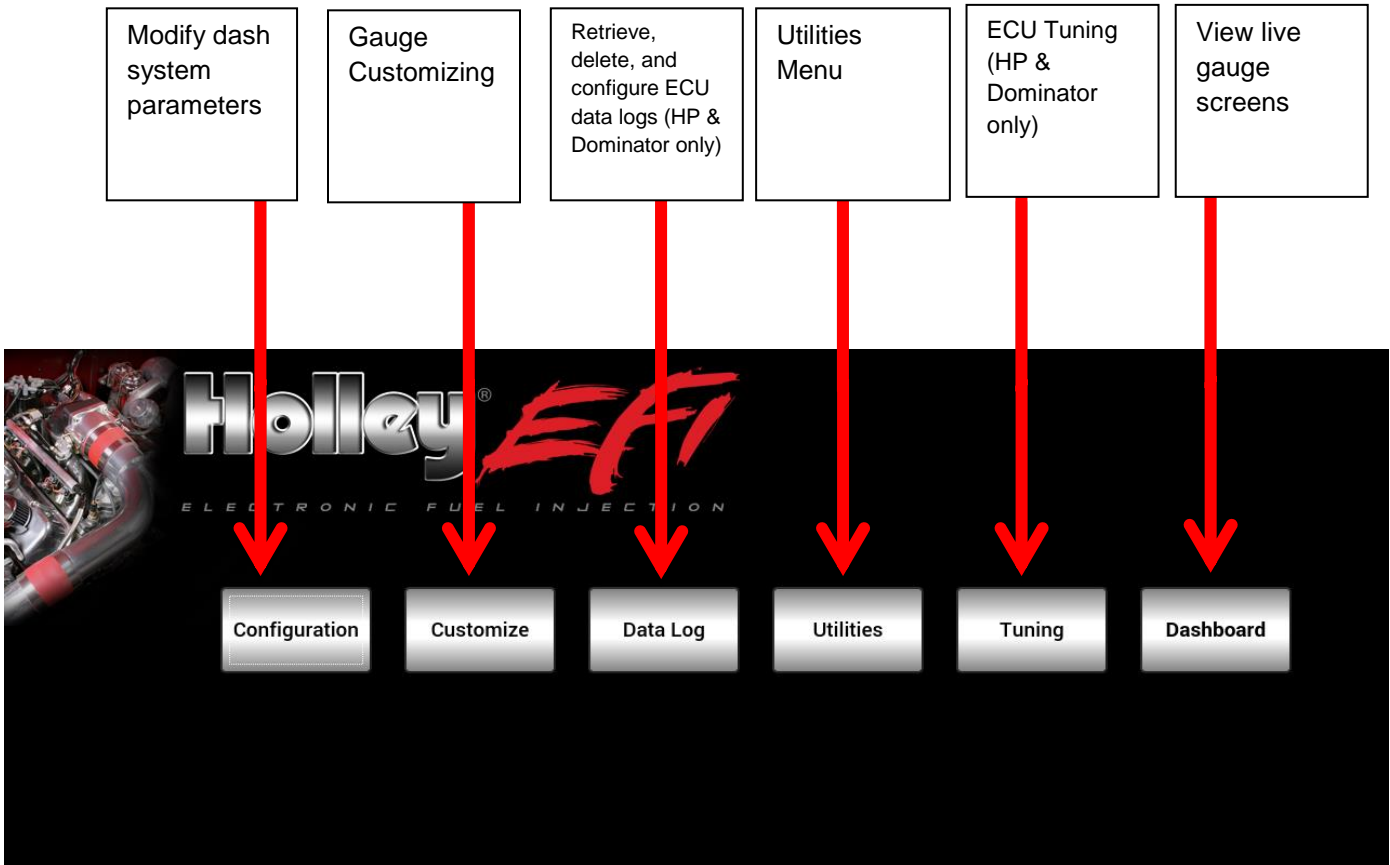

Standalone Setup

Press anywhere on the background to call up the side menu, then press Main Menu. Now press "Configuration" to get the dash configuration screen. If the "Operating Mode" is not set to "Standalone (no EFI)", select that at this time.

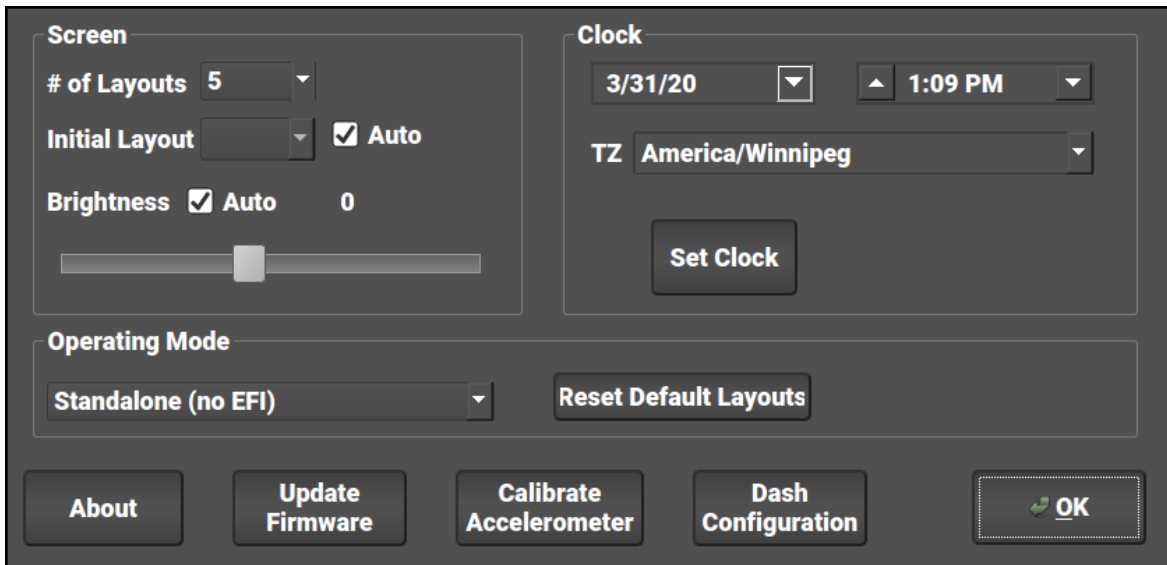

Underneath operating mode, select “Standalone”. Press “Reset Default Layouts” to install the default screens for standalone mode. This will ensure that the pre-configured standalone screens are loaded.

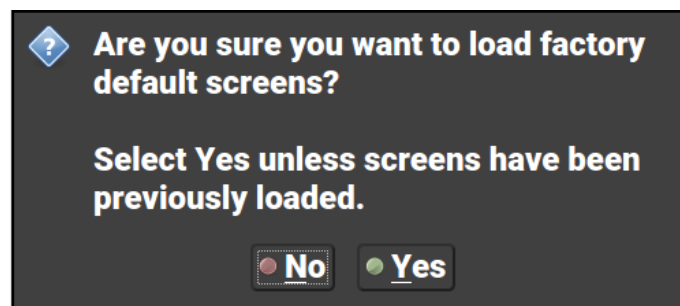

Now is also a good time to change the time zone shown in the TZ field to match the zone you are in.

Ready For Use

At this point the dash should be ready for use. Power the dash up. All of the predefined inputs contained in this manual should be reading. The GPS speedometer needs to be powered and driven briefly and should then show vehicle speed.

Preconfigured Gauge Screens

Standalone default screens are shown below. HP and Dominator, Sniper and Terminator X defaults will vary slightly



Layout 1

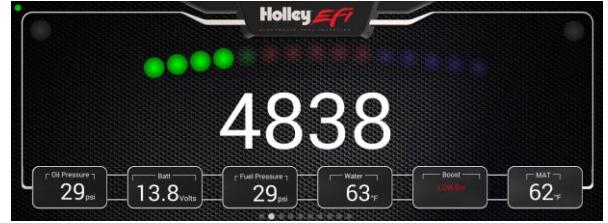

Layout 2



Layout 3



Layout 4



Layout 5



Layout 6



Layout 7



Layout 8



Layout 9

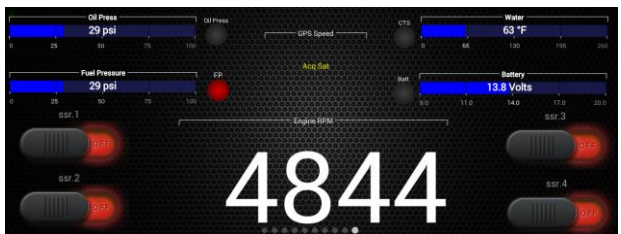

Layout 10

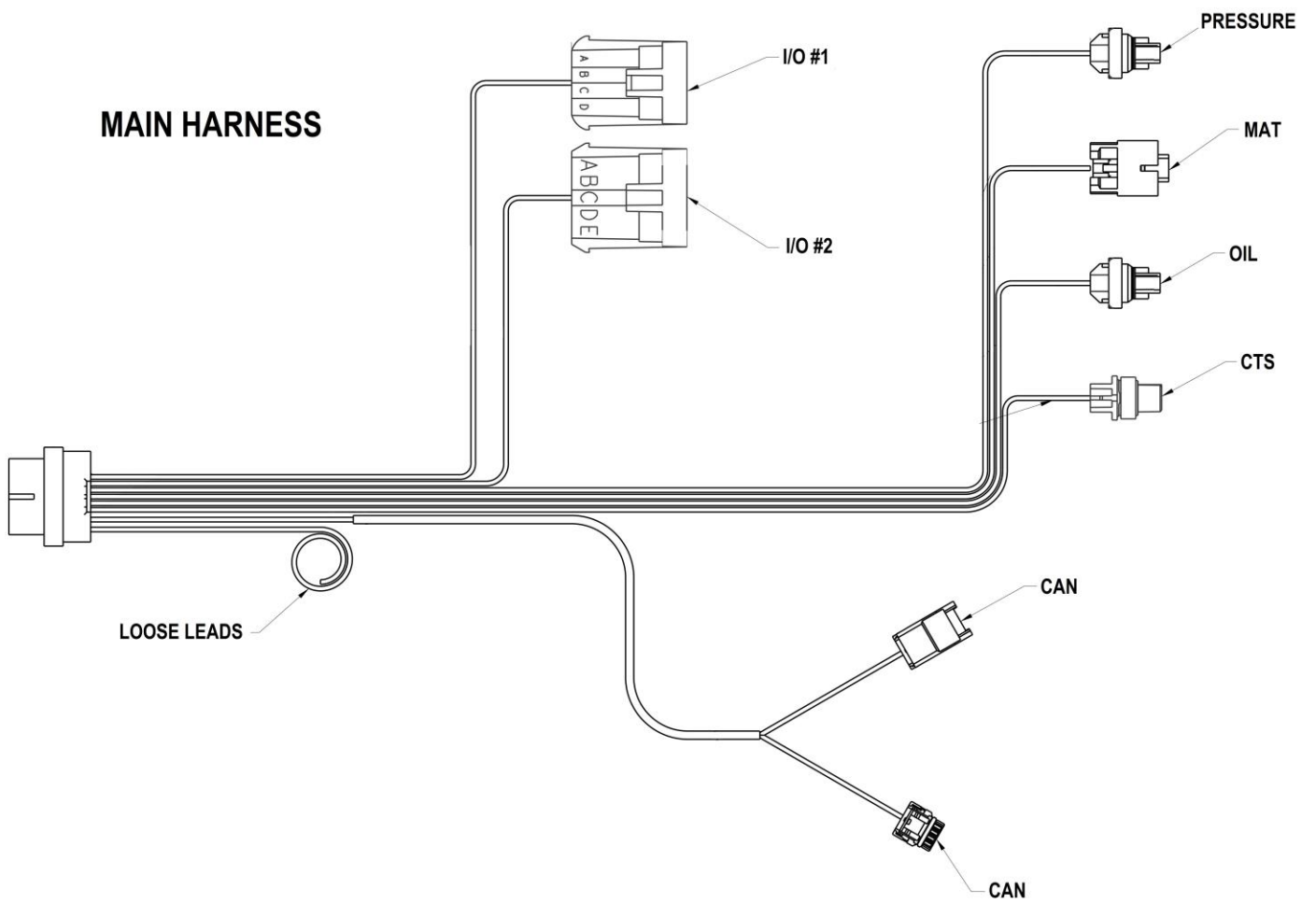

MAIN HARNESS

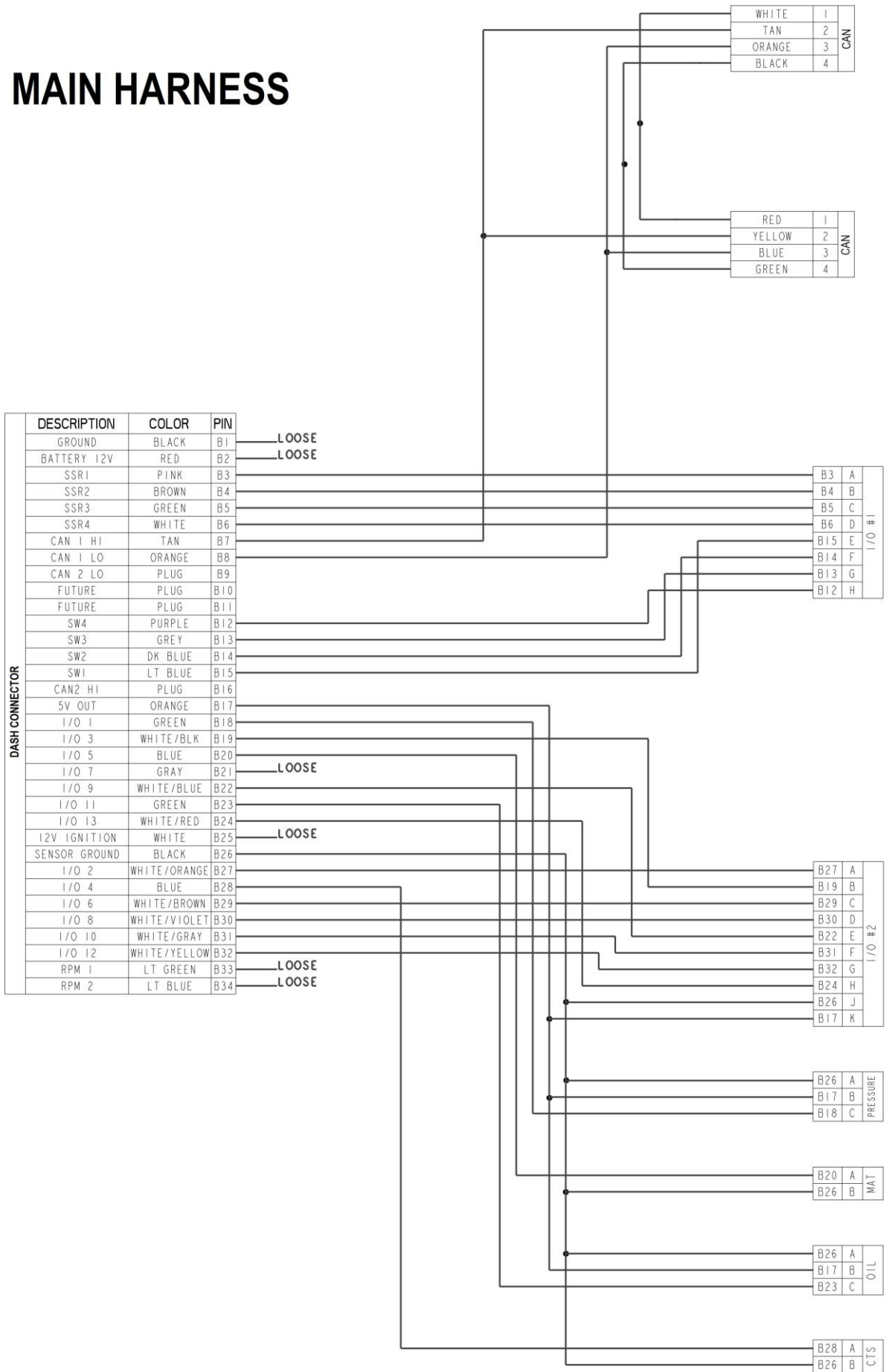

I/O #1 HARNESS

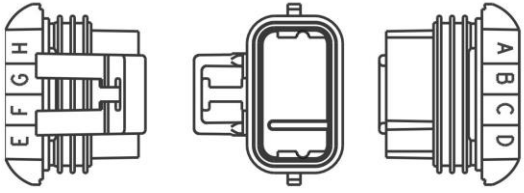

	COLOR	DASH CONNECTOR PIN	PIN	
I/O #1	PINK	B3	A	SSR1
	BROWN	B4	B	SSR2
	GREEN	B5	C	SSR3
	WHITE	B6	D	SSR4
	LT BLUE	B15	E	SW1
	DK BLUE	B14	F	SW2
	GREY	B13	G	SW3
	PURPLE	B12	H	SW4

I/O #2 HARNESS

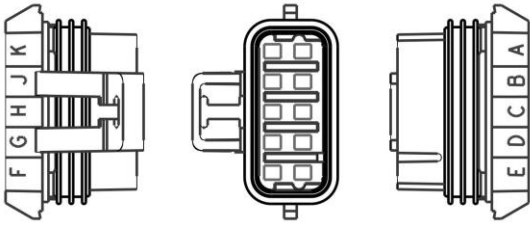

	COLOR	DASH CONNECTOR PIN	PIN	
I/O #2	WHITE/ORANGE	B27	A	I/O #2
	WHITE/BLACK	B19	B	I/O #3
	WHITE/BROWN	B29	C	I/O #6
	WHITE/VIOLET	B30	D	I/O #8
	WHITE/BLUE	B22	E	I/O #9
	WHITE/GREY	B31	F	I/O #10
	WHITE/YELLOW	B32	G	I/O #12
	WHITE/RED	B24	H	I/O #13
	BLACK	B26	J	SENSOR GROUND
	ORANGE	B17	K	SENSOR 5 VOLT

Holley Technical Support
1-866-464-6553

199R12074
Date: 5-29-20