

MAGNUSON

SUPERCHARGERS

Installation Instructions for:

2016-2019 LT1 Chevrolet Camaro Magnum DI Supercharger System



Step-by-step instructions for installing the best in supercharger systems.

*** PREMIUM GASOLINE FUEL REQUIRED ***

ATTENTION!

Your **MAGNUSON SUPERCHARGER** kit is sensitive to corrosion!

Use only the vehicle manufacturer recommended coolant for your engine in the intercooler system as well.



Magnuson Superchargers
1990 Knoll Drive, Bldg A, Ventura, CA. 93003
(805) 642-8833
magnusonsuperchargers.com

INSTALLATION MANUAL

Magnuson Superchargers Magnum DI GM 6.2L Engine 2016-2019 LT1 Chevrolet Camaro

Please take a few moments to review this manual thoroughly before you begin work. Make a quick parts check to be certain your kit is complete (see shipper parts list in this package). If you discover shipping damage or shortage, please call our office immediately. Take a look at exactly what you are going to need in terms of tools, time, and experience. Review our limited warranty with care. When unpacking the supercharger kit DO NOT lift the supercharger assembly by the black plastic bypass actuator. This is pre-set from the factory and can be altered if used as a lifting point!

Caution: Relieve the fuel system pressure before servicing fuel system components in order to reduce the risk of fire and personal injury. After relieving the system pressure, a small amount of fuel may be released when servicing the fuel lines or connections. In order to reduce the risk of personal injury, cover the regulator and fuel line fittings with a shop towel before disconnecting. This will catch any fuel that may leak out. Place the towel in an approved container when the job is complete.

Use only premium gasoline fuel, 91 octane or better.

Our Magnuson Superchargers kits are designed for engines in good mechanical condition only. Installation on high mileage or damaged engines is not recommended and may result in engine failure, for which we are not responsible. Magnuson Superchargers is not responsible for the engine or consequential damages.

Magnuson Superchargers kits are designed for use on stock vehicles. To that end, the alteration or modification of the fuel system, drive train, engine, and/or supercharger outside of stock parameters in any way can result in engine damage or failure for which Magnuson Superchargers is NOT responsible and will void Magnuson Superchargers warranty and CARB certification. Aftermarket engine recalibration devices that modify fuel and spark curve (including, but not limited to programmers) are not recommended and may cause engine damage or failure. Use of non-Magnuson Superchargers approved programming will void all warranties. If you have any questions, call us.

A new GM fuel filter is recommended at the time of supercharger installation
Stock spark plugs and stock plug gap are recommended

Contact information:
Magnuson Superchargers
1990 Knoll Drive, Bldg A
Ventura, CA 93003
Sales/Tech support 805-642-8833
Website:
www.magnusonsuperchargers.com
Email:
sales@magnusonsuperchargers.com

Table of Contents

Section 1: Tuning Your Vehicle Computer and Initial Steps	4
Section 2: Front Fascia Removal	6
Section 3: Coolant Drainage, and Airbox Removal	11
Section 4: Electrical and Hose Line Disconnect	14
Section 5: Fuel Line and Manifold Removal	18
Section 6: PCV Re-routing, Belt and Fan Removal	23
Section 7: Crank Pulley Replacement, and Idler Installation	31
Section 8: Coil Pack Removal, and Stud Installation	37
Section 9: Supercharger Preparation and Installation	41
Section 10: LTR Installation, and Horn Relocation	46
Section 11: Intercooler Pump Plumbing, and Electrical Connection	55
Section 12: CAC Installation	65
Section 13: Final Assembly and Testing	73

NOTE: This instruction manual follows the process we used to complete this installation on our test vehicle. This does not imply there aren't alternate approaches.

Tools Required:

- Metric wrench set
- 1/4" - 3/8" and 1/2" drive metric socket set with 22mm and 24mm(Standard & Deep)
- 3/8" and 1/2" drive Foot pound and inch pound torque wrenches
- 1/2" breaker
- Metric Allen socket set with 3/8" drive
- Phillips, flat and Torx head screwdrivers
- Fuel line quick disconnect tool (included in kit)
- Small or angled 3/8" drill motor
- 1/2" Impact wrench
- Drain pan and funnel
- Hose cutters and hose clamp pliers
- Safety glasses
- Shop vacuum cleaner
- Pry tool and nut driver
- Rotary Cutter or Hacksaw
- Bandsaw
- Loctite 242

*** PLEASE PAY ATTENTION TO THE STEPS IN THIS INSTRUCTION MANUAL. ENGINE DAMAGE CAN OCCUR IF YOU DO NOT FOLLOW THE INSTRUCTIONS. ***

NOTE: For the purpose of these instructions all references to left or right side are assumed to be as indicated from the seated position in the driver seat of the vehicle.

Section 1: Tuning Your Vehicle Computer and Initial Steps

1. **If your kit has a provided handheld tuner follow the instructions in the provided pamphlet to install your tune. Your handheld tuner may not match the one shown.**



2. Your Intercooler system is sensitive to corrosion. It's very important to use the OEM recommended coolant mixture in your supercharger system as well.



3. Your system requires the use of minimum 91 Octane gasoline fuel. This system is **not** compatible with E85 fuel.

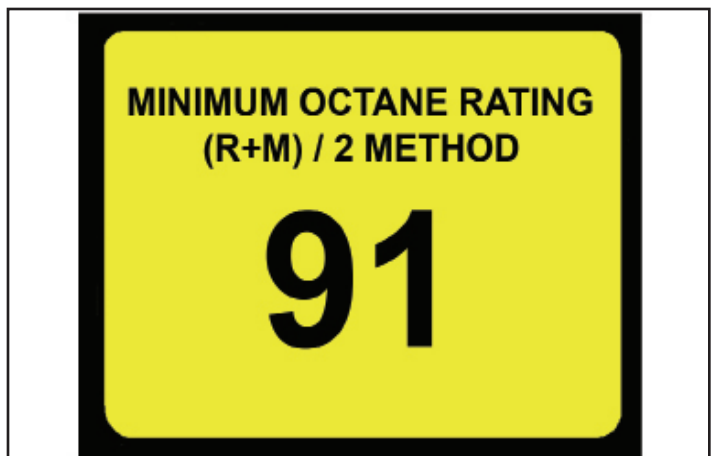

4. Open the trunk and look to your right. Grab the handle shown with the arrow, and pull the panel cover off. Behind this you will find the battery.

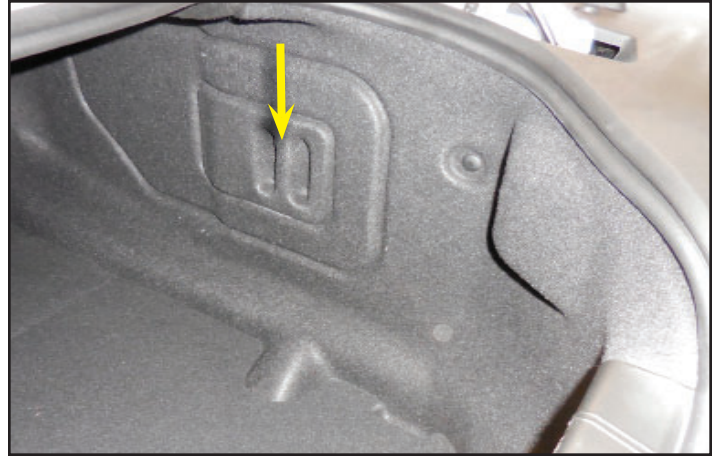

5. Loosen the nut shown with an arrow to disconnect the negative battery terminal. Cap or cover the terminal to protect against accidental contact with the battery post.



6. Place a rag over the latch area so the trunk does not accidentally get locked.



7. Follow the instructions in your owner's manual for vehicle lifting, and front wheel removal. Only the front wheels will need to be removed.

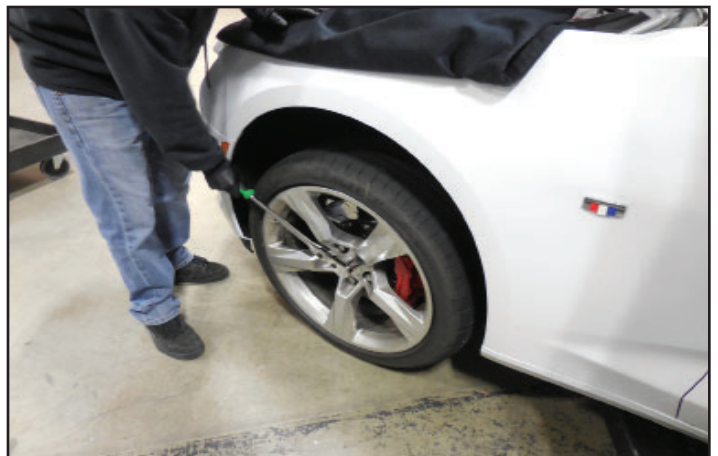

Section 2: Front Fascia Removal

8. Remove the 5 bolts holding the air deflectors in place on each side with a 7mm socket. The deflectors are located in front of the front wheels on both sides. This photo was taken from below the vehicle. The bolt locations for the right side are shown with arrows in this image. Repeat on the left side. Keep the hardware organized and labeled. There will be many different sizes and types in the next few steps.

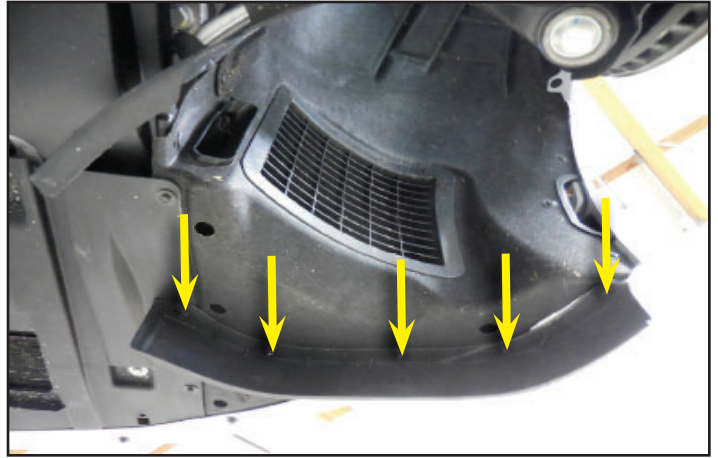

9. This photo is from the underside of the vehicle as viewed from the front. This center cover will be removed by taking out the following fasteners. Use a 7mm wrench to remove the 8 bolts shown with red arrows. Use a 10 mm wrench to remove the 6 bolts shown with yellow arrows. Remove the plastic rivet at the green arrow location. To remove the rivet pull the center part out first followed by the outer section. Once the rivet has been removed the center cover will be loose.

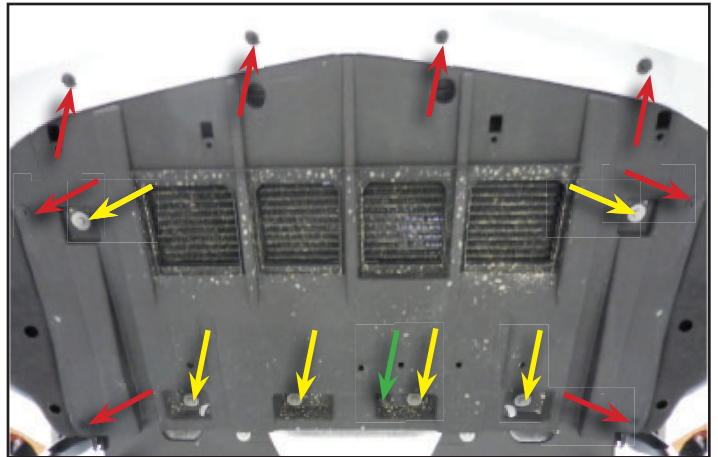

10. At this point the center cover can be removed from the underside of the vehicle.



11. Use a T15 Torx bit to remove the fasteners at the 5 yellow arrow locations. Also there is one plastic rivet at the red arrow location that must be removed. Once all these fasteners have been removed you can remove the panel that they were securing.

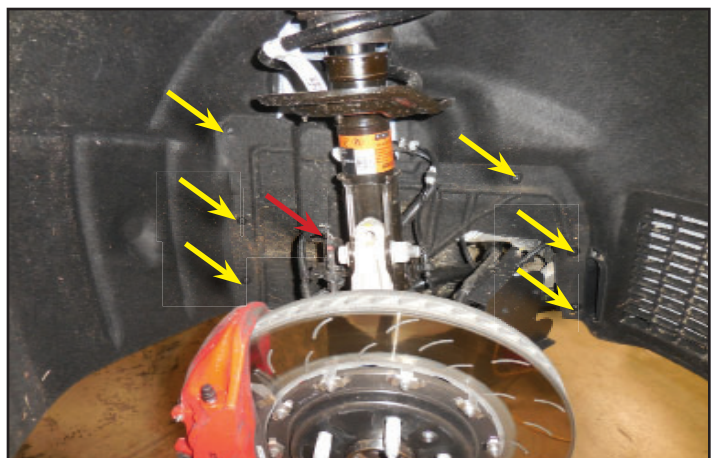

12. Use a 7mm wrench to remove the two fasteners shown with yellow arrows.

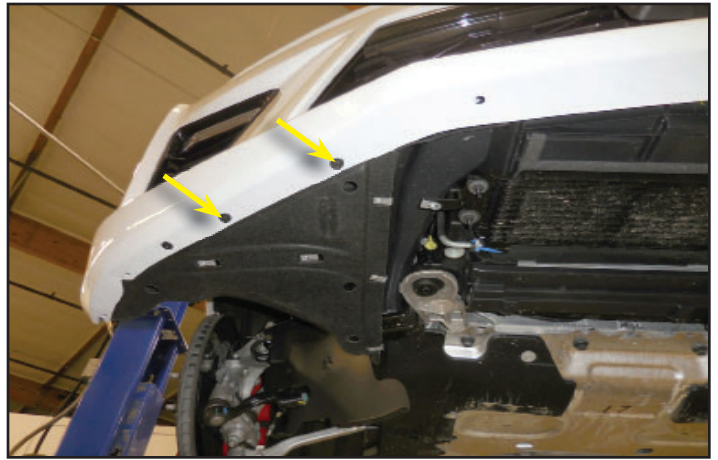

13. Remove the three push rivets from the locations shown with yellow arrows. Use a T15 Torx wrench to remove the 7 bolts shown with red arrows.

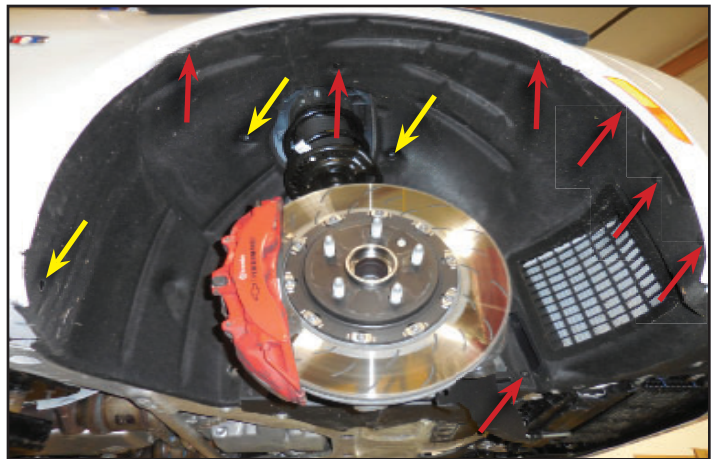

14. Pull in on the sides of the wheel well liner and push the center area down to clear the two metal tabs on the fender lip. Be careful not to tear the liner as you remove it. Once you have cleared the two tabs on the fender lip you should be able to pull the wheel well liner out. Repeat the last three steps to remove the left side wheel well liner.



15. Use a T15 bit to remove the 6 bolts shown with yellow arrows. Remove the two push rivets in the two red arrow locations.



16. Remove the plastic trim from both sides by gently pulling straight up.



17. Use a 7mm socket to remove the three bolts in each fender well shown with yellow arrows.

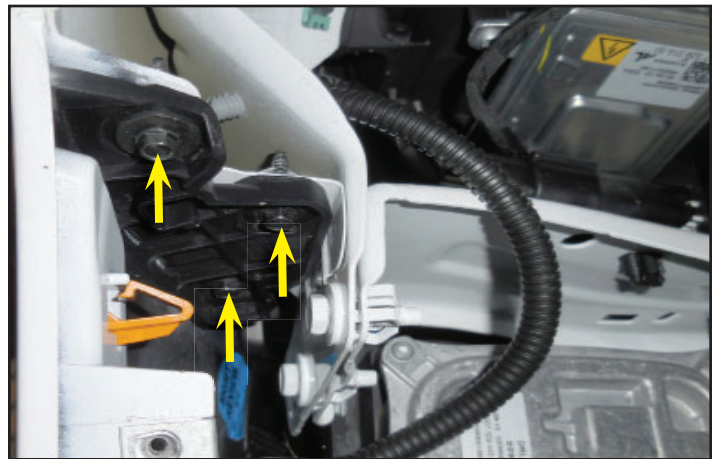

18. Remove the plastic bracket from the last step by pushing it slightly forward and pulling down then disengage the hook that is shown with an arrow.

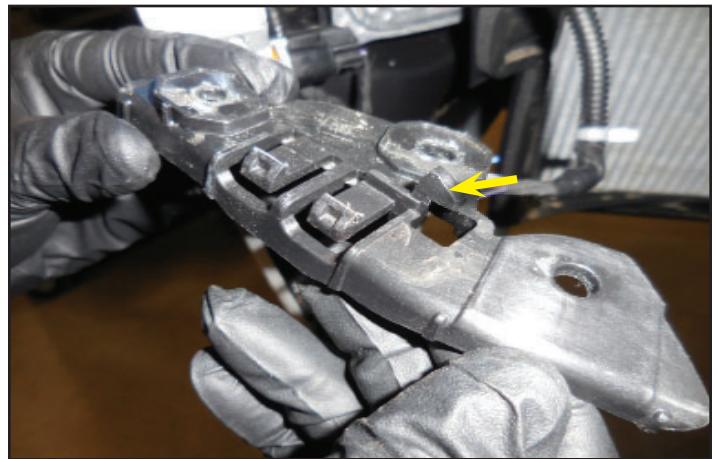

19. Use a 7mm wrench to remove the 4 bolts around the back of the headlight that are shown here with arrows.



20. Disconnect the electrical plug shown with an arrow that is located in the right fender well.



21. Remove the retaining clip shown at the arrow location with a small pry bar.



22. Apply painters tape to the fender, and fascia, near the seam on both sides as shown in the photo. This will help to protect your paint while you remove the front fascia.



23. Have someone help you with the removal of the front fascia. Pull gently around the interface between the fender and the fascia to release the connections holding it in place. Then pull the fascia forward.



24. Use a 10 mm wrench to remove the 4 bolts shown with yellow arrows.

Do Not remove the two bolts shown with red arrows. The two bolts with red arrows are for adjustment purposes.

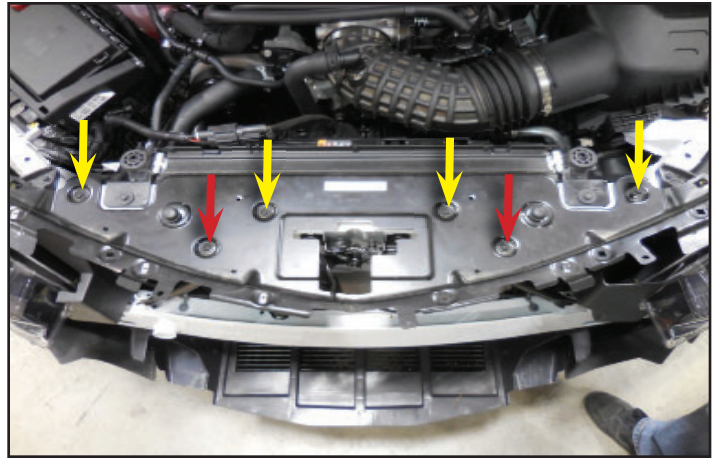

25. Remove the panel covering the latch mechanism that is shown.

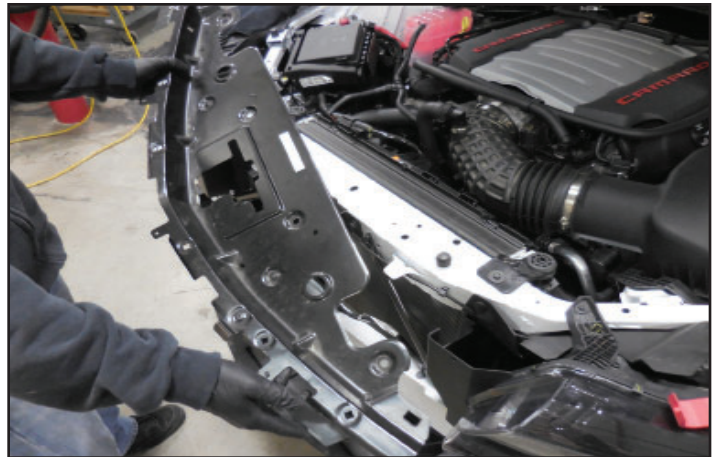

26. Use a pencil to mark around the flange of the two bolt heads securing the hood latch assembly. After marking the bolt locations use a 15 mm wrench to remove the two bolts shown with arrows.

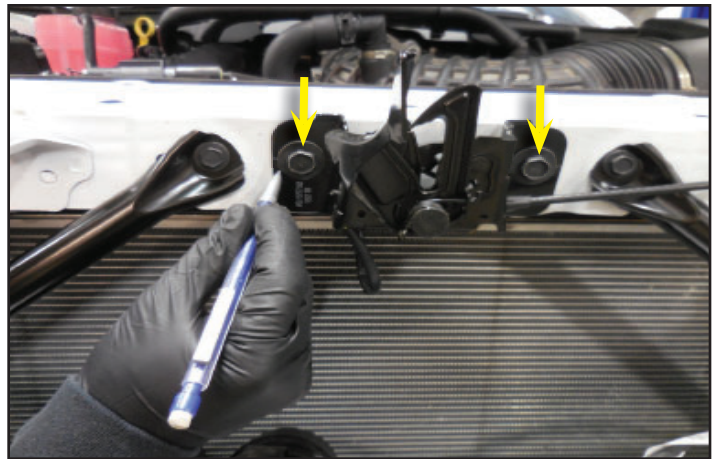

27. Remove the electrical connection that connects to the hood latch. It is held in place by a clip and is located under the cross support behind the location for the hood latch.



28. Pull the white release clip and unplug the connection shown.



29. Use pliers to compress the plastic fitting holding the cable housing to the latch bracket. This will allow you to push the housing away from the bracket.



30. Use needle nose pliers to grab the ball end of the actuator cable for the hood latch. Pull the ball out of its socket to remove the cable from the latch assembly.

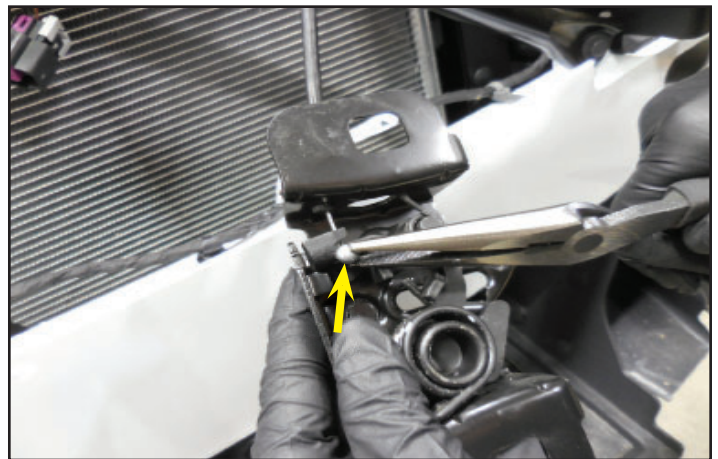

Section 3: Coolant Drainage, and Airbox Removal

Make sure your vehicle has cooled down before proceeding.

31. Remove the radiator reservoir cap to help the fluid to drain faster in the next step.



32. Place a clean drain pan under the radiator drain spigot located on the front right side of the vehicle. Loosen the valve shown with an arrow until the fluid begins to drain. Once the fluid has drained completely close the drain valve, and re-install the radiator reservoir cap. This will take about 15-20 minutes.



33. Remove the hose that is being held in this photo by first disconnecting it from the clip shown with a green arrow, and then disconnecting the two ends shown with yellow arrows.

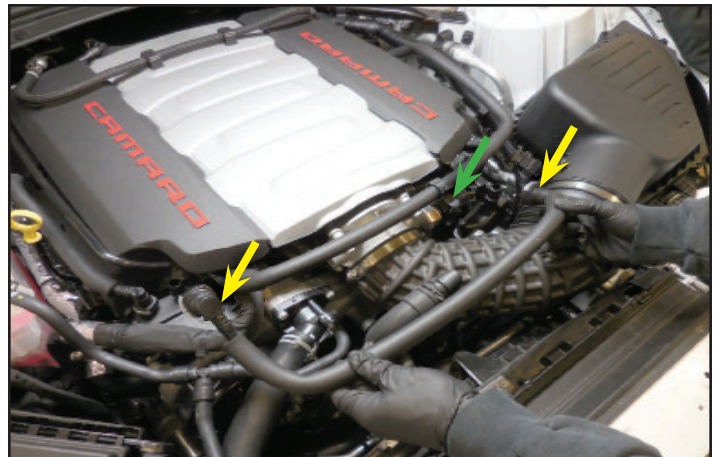

34. Disconnect the air hose going to the air inlet duct located at the front of the engine.

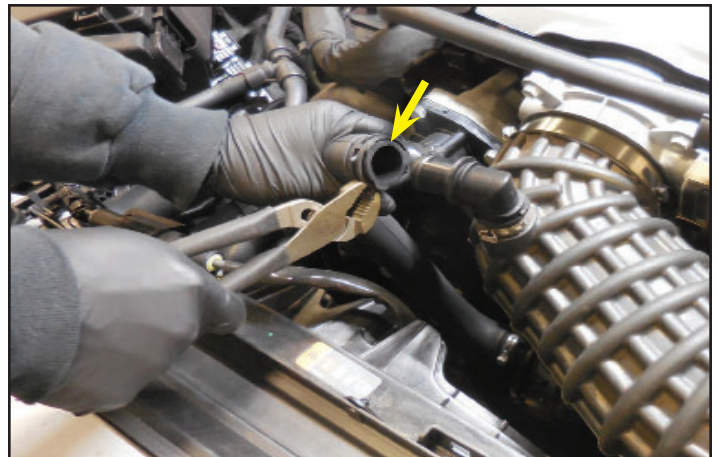

35. Use an 8mm nut driver to remove the two hose clamps from the air inlet duct and remove the duct.



36. Unplug the connection from the MAF sensor by first pulling back on the red release lock located on the underside of the connector.

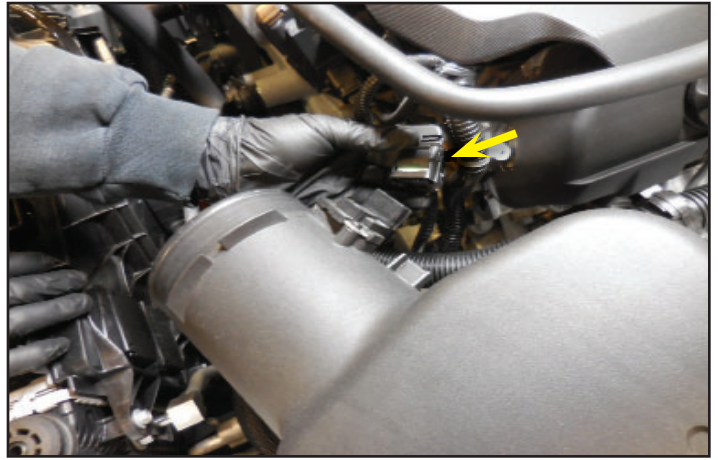

37. Open the plastic hose clamp attached to the airbox shown with the arrow.



38. Pull up at the area of the airbox shown with an arrow. This will release the airbox so you can pull it up and out of the engine bay.



39. If any of the rubber connectors remain on the airbox they should be removed and installed into their original location on the fender well shown here with arrows.

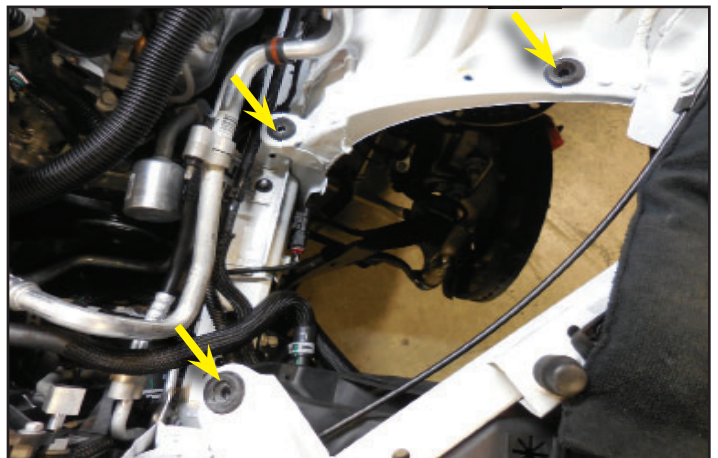

Section 4: Electrical and Hose Line Disconnect

40. Disconnect the clamp holding the air hose to the air conditioning line.



41. Disconnect the air hose at the location shown by first squeezing the two sides shown with arrows and then pulling it apart.



42. Remove the two bolts that hold the resonator bracket in place using a T50 torx driver.

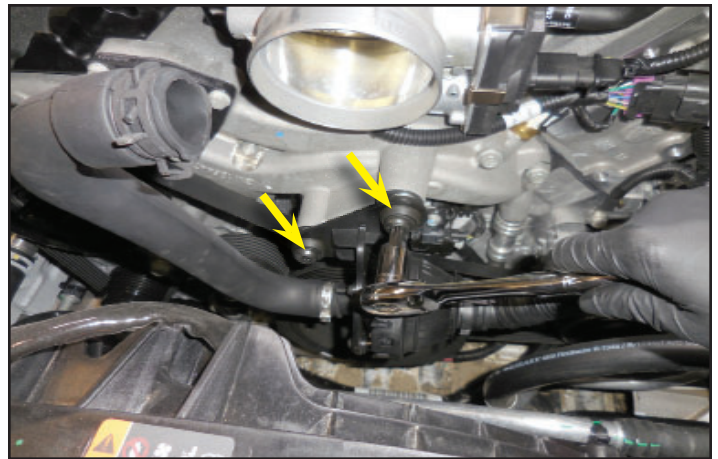

43. Remove the resonator assembly shown.



44. Install the provided plug into resonator hose connection shown.

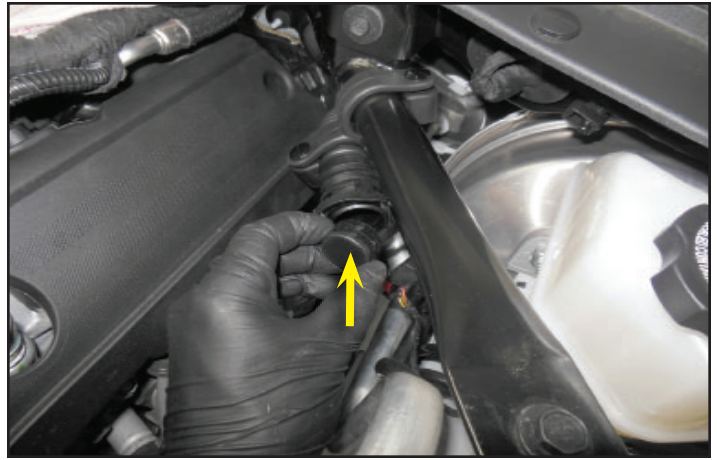

45. Rotate the resonator hose behind the brace.



46. Open the two retainer clamps shown with the yellow arrows.



47. Pull up at the side closer to the middle of the engine on the "Camaro" beauty covers (shown with arrows) to remove them.

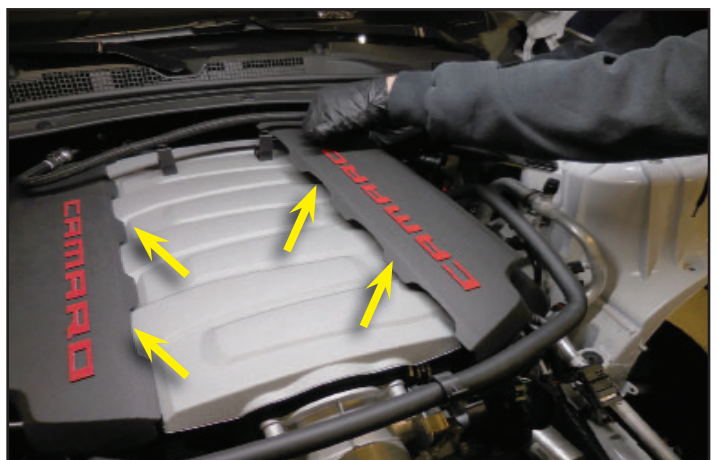

48. Unplug the Manifold Absolute Pressure (MAP) connection shown.



49. Clip the connections holding the coil wiring harness to the center cover. There are 4 of these cable ties on each side.



50. Use a 10 mm deep-well socket to remove the four mounting studs shown with arrows. Remove the bracket from the engine. These are also the locations where the "Camaro" beauty covers were attached. Now remove the manifold cover.



51. Remove the EVAP line that is being held in this photo at the arrow locations.



52. Release the white locking tap by pulling it out and then unplug the electrical connection to the EVAP solenoid.



53. Release the white locking tap by pulling it out and then unplug the electronic throttle control connection.



54. Disconnect the PCV connection shown with an arrow. There is a white release button that must be pressed first prior to removal. Many of the future hoses that need to be removed will have this same release button.



55. Press the release buttons on the hose connections and disconnect them from the two locations on the oil separator shown with arrows.



56. Use a T30 Torx driver to remove the two bolts shown with yellow arrows. Remove the oil filler cap shown with a red arrow. **Ensure that nothing gets down inside the oil filler tube while the cap is removed.** Now slide the coil pack cover out of the way and unplug the hose shown with the green arrow. Then remove the left side coil pack cover.

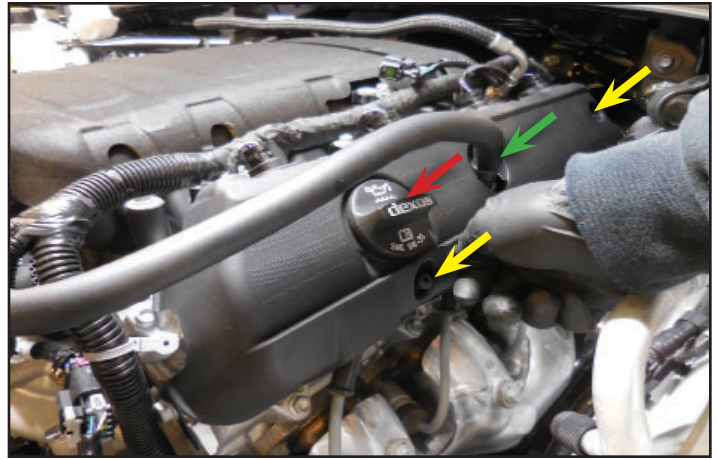

57. **After you have removed the cover make sure to re-install the oil filler cap.**



58. Use a T30 Torx driver to remove the two bolts holding the right side coil cover. Once you have the coil cover loose you will be able to access the connection for the hose line shown with an arrow. Remove this hose.



Section 5: Fuel Line and Manifold Removal

59. Open the gas filler cover, and open the valve flap internally with a clean finger to relieve the fuel system pressure.



60. Place rags around the fuel line shown at the left side of the engine. Remove the metal locking clip from the fuel line.



61. **Eye protection is necessary.** Use the provided plastic release tool to slide on the underside of the hose connection (shown with an arrow) and press up on it while you push down on the hose. This will release the connection. Be careful while releasing the connection because fuel will be released. Properly dispose of any fuel soaked rags after fuel line is removed.



62. Place a cap on the fuel inlet line shown with a red arrow, and a plug on the hose (shown with a yellow arrow) once the fuel line has been disconnected.



63. Follow the same procedure to remove the fuel line connection on the opposite side of the hose you just disconnected. Cap the line once it has been disconnected.



64. Press the release button on the brake booster hose shown and disconnect it.

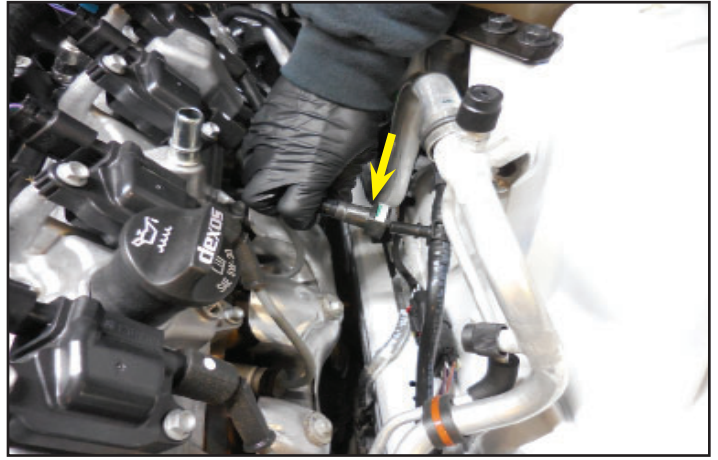

65. Use a 10 mm wrench to remove the 10 bolts shown with arrows. Remove the intake manifold.

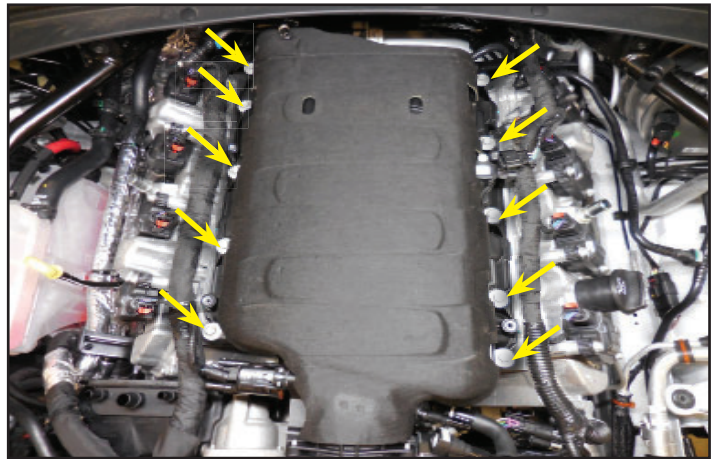

66. Press the release button on the PCV valve hose and disconnect it.



67. Vacuum out any debris that is near the manifold valley. **Ensure that nothing gets inside the intake runners. Inspect the intake runners for any debris.** Remove the foam insulation shown.



68. Clean the sealing surfaces of the intake ports with Simple Green followed by denatured alcohol. **Inspect the intake ports once again for any debris that may have fallen in.** Remove any debris if necessary. Install painters tape on each port to prevent anything from falling inside.

It's VERY important to not contaminate your work environment or allow any debris to fall into the exposed ports, engine damage CAN occur.

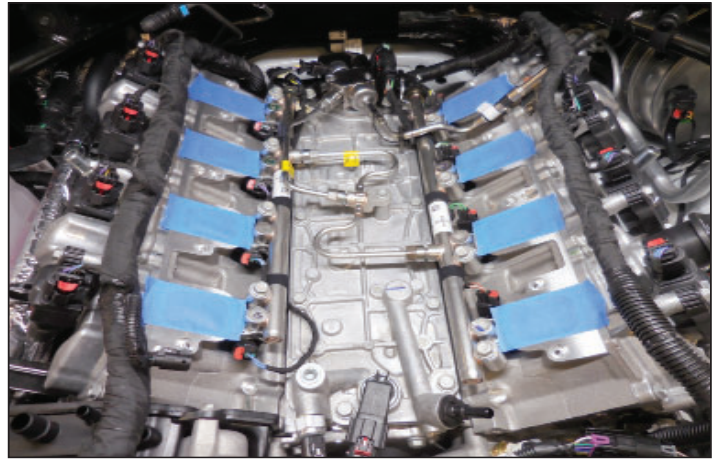

69. Use a 10 mm socket wrench to remove the fuel line bracket.

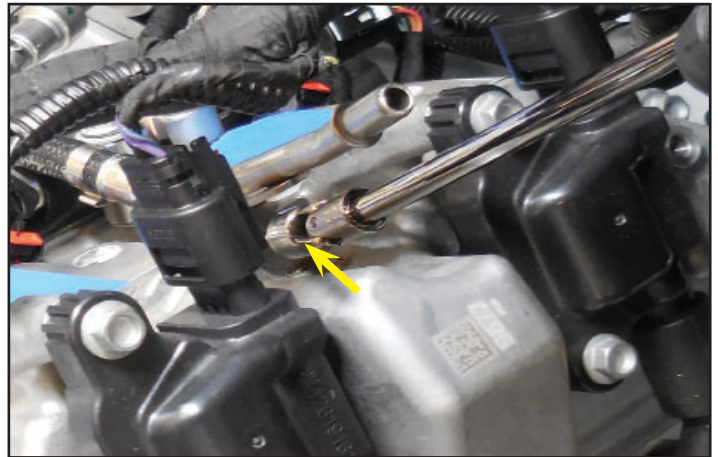

70. Remove the steel security clip from the fuel line shown with the yellow arrow. Also remove the plastic tether shown with the red arrow.



71. Once again use the provided fuel line removal tool to disconnect the fuel line on the opposite side of the OEM fuel line. **This fuel line will not be reused.**



72. Gather the provided fuel line shown. This will replace the fuel line just removed.



73. Install the provided fuel line by routing it in the location shown highlighted in green. **Ensure that you slide the hose under hardline shown with the red arrow.** The end connections will be shown in the following steps.

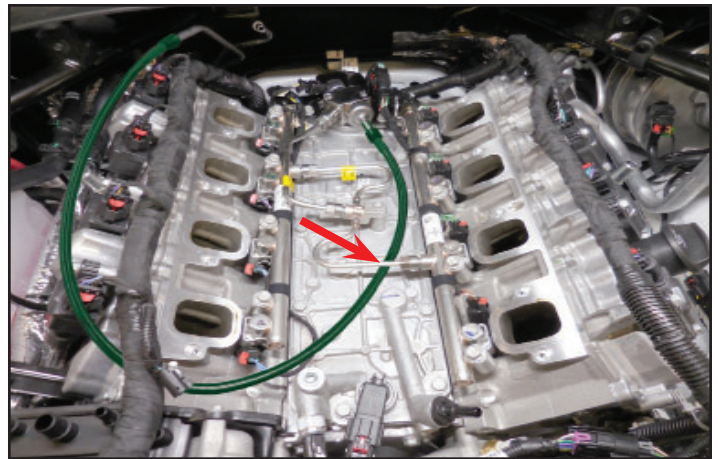

74. Remove the securing slotted nut from the female hose end.

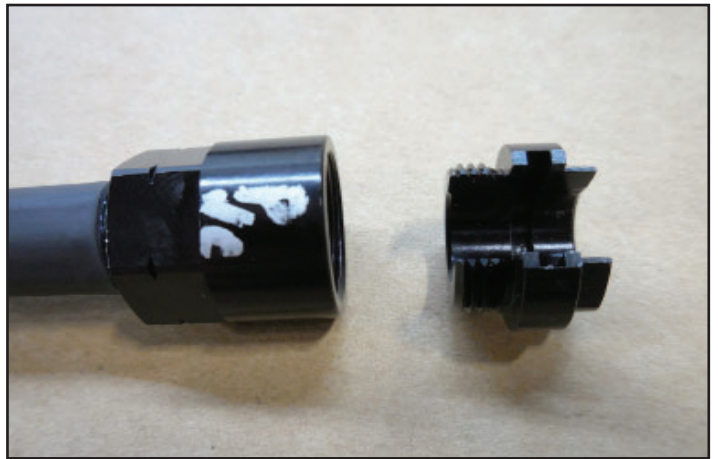

75. Slide the slotted nut that was removed in the last step over the flange on the male fuel fitting as shown with the arrow.



76. Hand tighten the slotted nut onto the female fuel line. You may have to bend the hose slightly with your hands at the end to thread the nut.



77. Tighten the fuel line securely with wrenches. You may find it easier to tighten the slotted nut with a flare nut wrench rather than an open end wrench. Repeat this process on the other side of the fuel line.

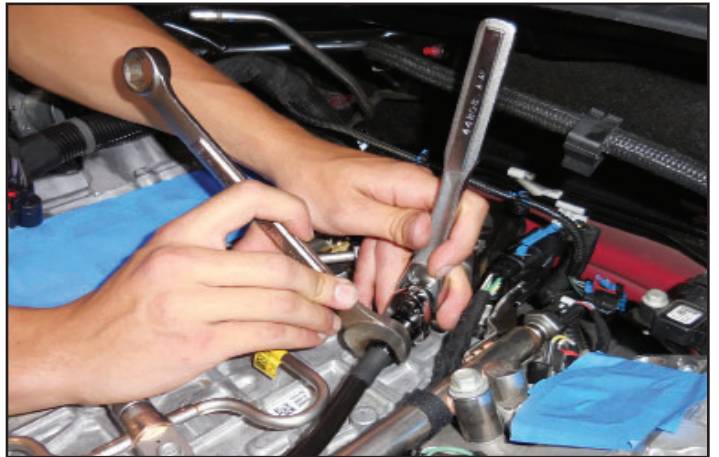

Section 6: PCV Re-routing, Belt and Fan Removal

78. Remove the PCV valve using a 24 mm deep well socket and ratchet wrench.



79. Gather the following provided parts. Install the nut with the flanged end facing away from the bolt head. Ensure that the nut is threaded on completely. The spacer will be installed on the bolt in the next step.



80. Slide the spacer over the bolt and thread the bolt into the plug located near the PCV valve that was just removed. Make sure the bolt is properly centered in the plug area, and press inwards as you rotate the bolt clockwise with a ratchet wrench. Continue to tighten until you get three threads or about 1/4" of engagement from the bolt into the plug.

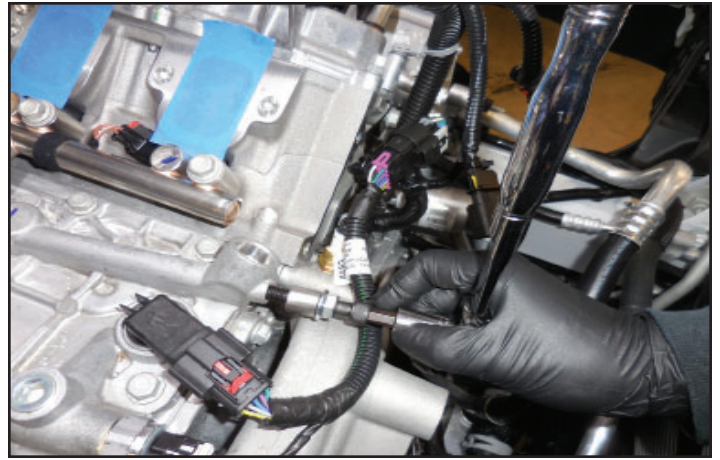

81. Use a heat gun to heat up the area around the plug. Heat for about 45 seconds. This will soften the Loctite and allow you to extract the plug. **Be careful not to melt any wires or plastic connectors.**



82. Once the Loctite has softened you can tighten the nut with a 9/16" wrench. This will pull the plug from the bore.



83. Here is a close-up of the extracted plug.



84. Clean the bore area where the plug was with a cotton swab. After the larger particles have been cleaned out use denatured alcohol, or acetone to clean out the bore thoroughly.

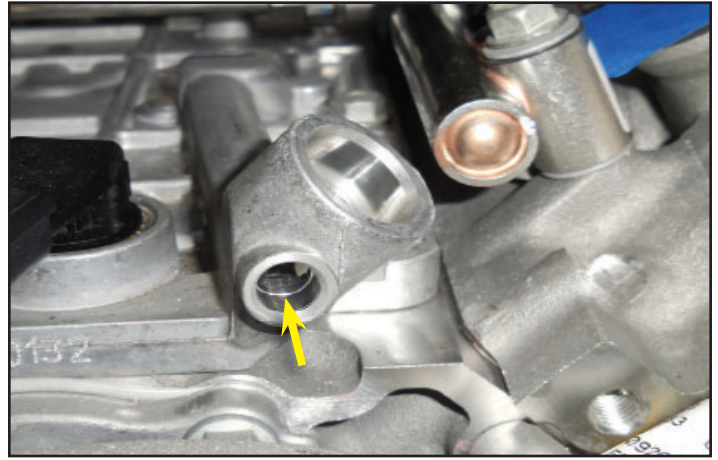

85. Gather the following provided threaded plug. **Apply the provided Lubriplate grease to the O-ring of this plug that will be installed where the PCV valve was.**

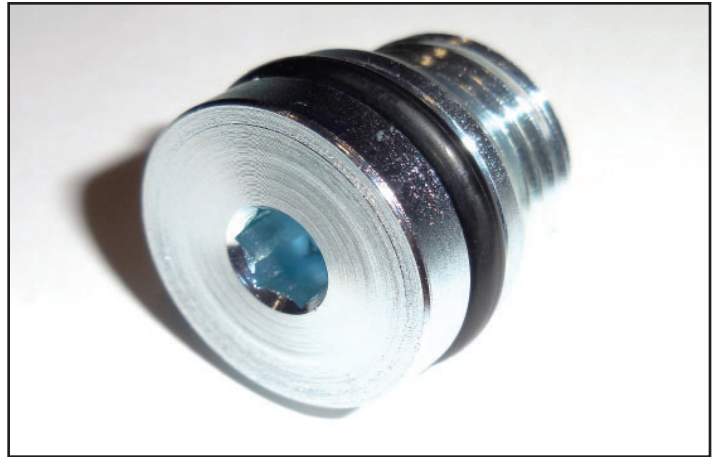

86. Use a 6 mm Allen wrench to install the provided threaded plug from the last step in the location where the PCV valve was.

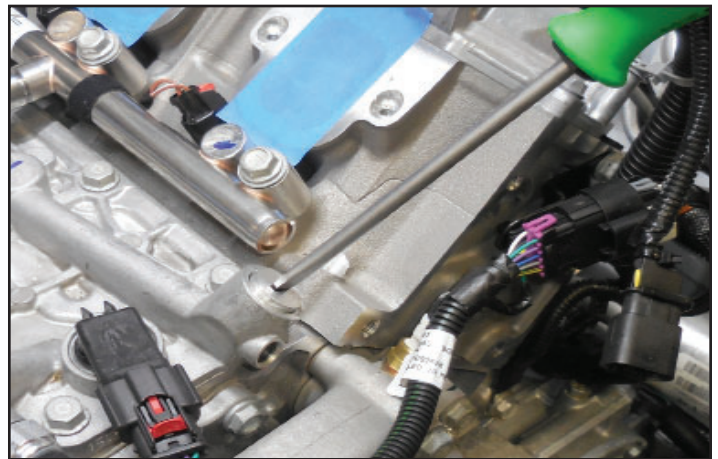

87. **Apply a thin bead of the supplied green Loctite 680 to the outside of the supplied air tube shown.**



88. Install the supplied air tube in the end of the bore that the plug was removed from and lightly tap it in place until it bottoms out. The area where the air tube steps down to the smaller diameter should be flush with the outer edge of the bore.



89. Use a 15 mm socket and a ratchet wrench or breaker bar to attach at the tensioner shown with the arrow. Turn the tensioner clockwise to relieve the tension in the belt, and remove the belt.



90. Use a 24 mm socket and a ratchet wrench to rotate the crank pulley clockwise. While you rotate the pulley apply outward force to pull the A/C belt off. It will take several turns of the belt to get it to jump all the grooves and come off the A/C compressor pulley. **Be careful to not pinch your fingers/hand between the belt and A/C pulley.**



91. Cover pulleys with rags as shown to protect them from getting any fluid deposits.

It's VERY IMPORTANT to not get coolant on your engine pulleys. The smallest amount can cause "Belt squeaking".



92. Disconnect the hose mounting clamps from the fan shroud at the three locations shown with arrows.

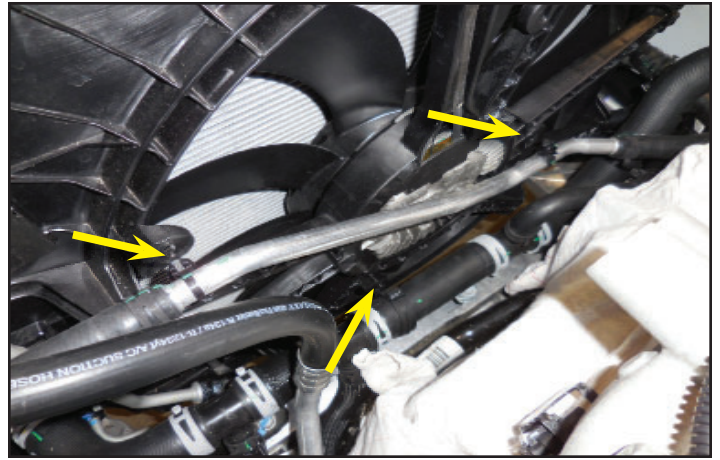

93. Dismount the electrical plug from the fan shroud at the two locations shown with an arrow.

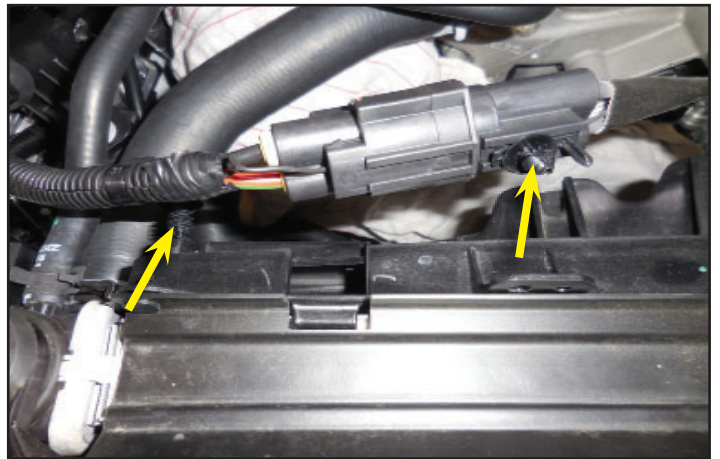

94. Remove the three plastic rivets shown with arrows holding the cover above the radiator. Now remove the cover.

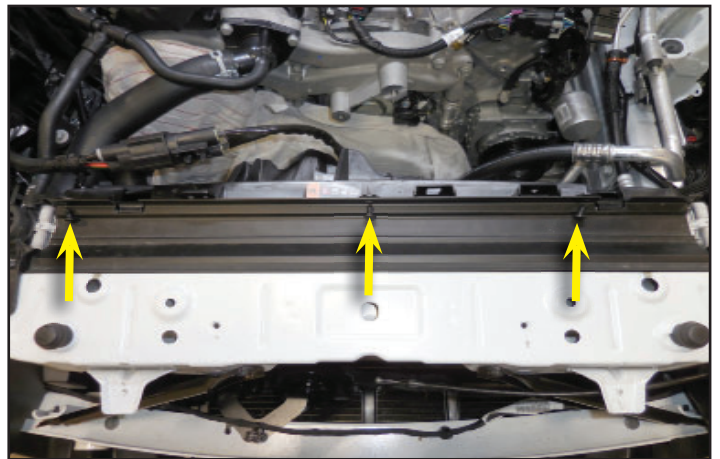

95. Disconnect the electrical connection for the fan shroud.



96. Mark the orientation of the radiator hose so it will get re-installed properly later. Remove the two spring clamps holding the upper radiator hose. Then remove the upper radiator hose.

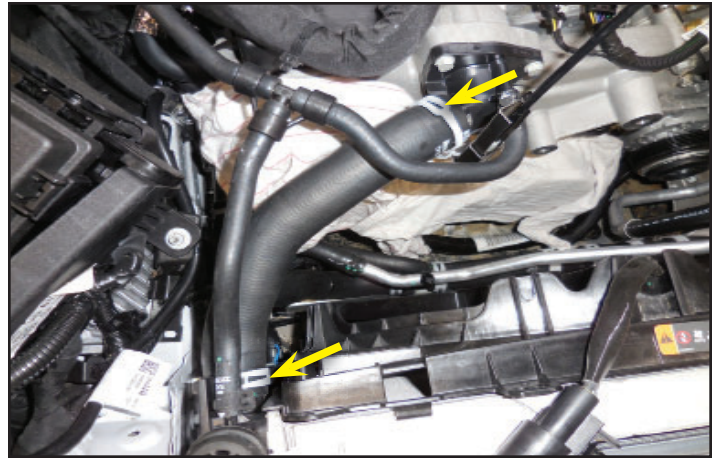

97. Plug both connection points for the hose that was removed in the last step with rags.



98. Disconnect the lower auxiliary coolant hose by removing the spring clamp. Double-X (or long reach) needle nose pliers are shown being used for this clamp. You will have to squeeze the clamp and pull the hose off at the same time. The clamp is glued to the hose and will not slide. Tuck this hose out of the way of the shroud.



99. On the left side of the radiator is a transmission cooler line that will be disconnected. First pull back the black plastic cover. Then remove the spring clip using a pick or small screwdriver. The next step shows a photo of the spring clip.

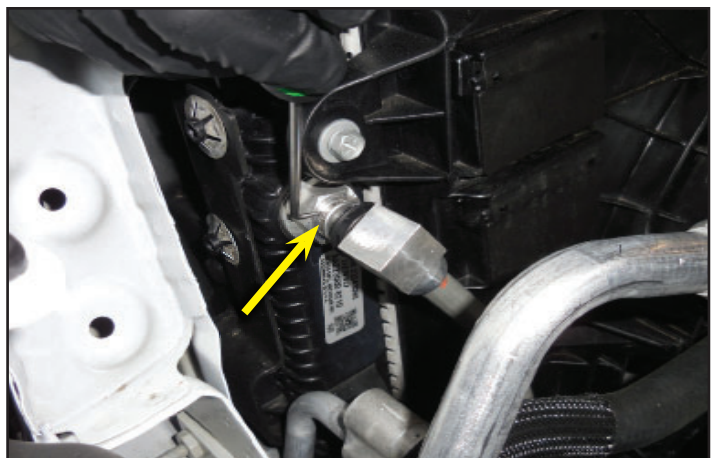

100. Here is the spring clip that was removed in the last step.

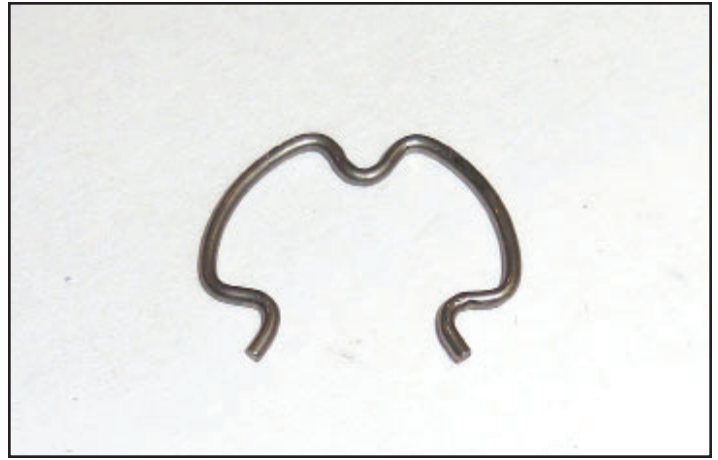

101. Once the spring clip is removed from the hose you can pull the hose out. Carefully clean the port out with a clean towel and plug the port to prevent any debris from entering. Also cap the hose to prevent any leakage. You can now disengage the hardline from the fan shroud.



102. Remove the two bolts at the top of the radiator that secure the fan shroud with a 10 mm socket wrench.



103. Here is the second location of the fan shroud mount located under the radiator spigot on the right side of the engine bay.

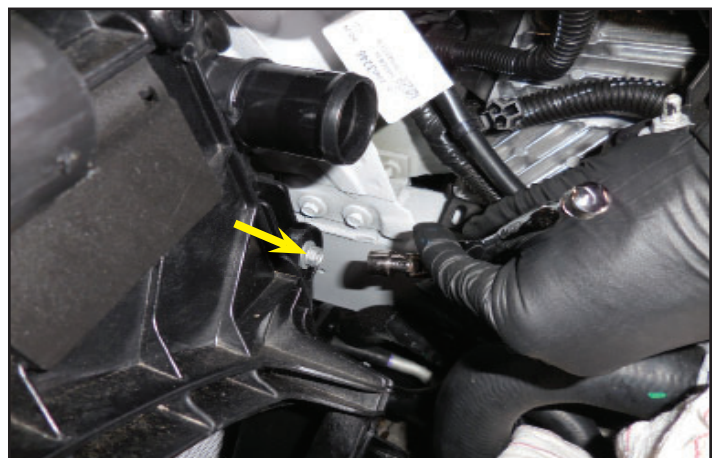

104. Remove the three lower fan shroud mounting bolts using a 7 mm socket wrench.

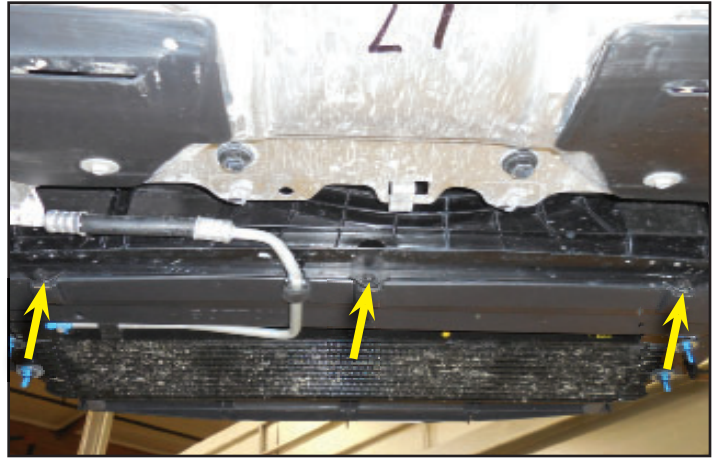

105. Disconnect the transmission cooler line from the clip shown with the yellow arrow.



106. Remove the fan shroud. This may require two people and some finesse. There are protrusions on the sides. These will have to be steered through the obstructions on the vehicle as it is removed from the engine compartment.



107. Cut a 24" x 24" piece of cardboard and tape it behind the radiator to protect it.



Section 7: Crank Pulley Replacement, and Idler Installation

108. Remove the crank bolt at the end of the crank pulley using a 24 mm impact socket, and an air impact gun. There is an auxiliary cooling line shown with an arrow that should also be disconnected to allow for more clearance. The line can be cable tied out of the way after it is disconnected.



109. You may have to heat the bolt with a heat gun or torch to soften the locking chemicals prior to removal with the impact gun. Save this bolt for a later step.



110. Install a three jaw puller to the pulley for removal. It is recommended to use a GM specific puller for this operation.



111. After the pulley is removed check the seal for any damage.

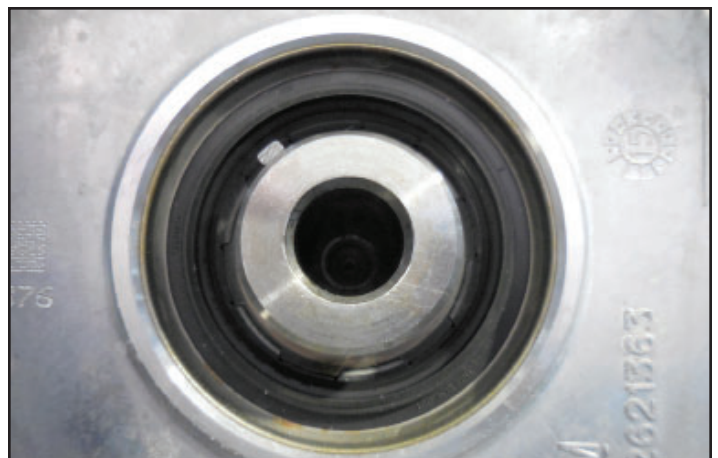

112. Gather the provided pulley and the new bolt. **Apply motor oil to the inner bore and the outer seal surface of the pulley shown with arrows.**



113. Apply motor oil to the crank seal.

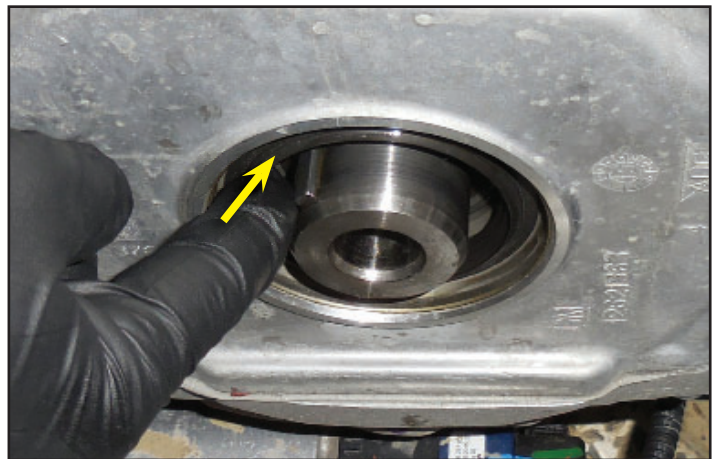

114. Install the provided pulley. Take note of the key way position on the crank, and line the provided pulley up with it.



115. Use a pulley installer tool to tighten the provided pulley in place. **Do Not use the provided bolt to install the pulley.** You may need to remove your starter and install a flywheel locking tool in order to properly torque your pulley in place. Once the pulley has been fully seated with the pulley installer tool install the old crank bolt that was removed from the original pulley. **Torque this bolt to 240 ft-lbs.** Discard the old bolt once this step is done.



116. Once the last step has been performed use a 24 mm socket to install the **new provided** crank pulley bolt according to the following GM specifications. **First torque the provided bolt to 111 ft-lbs. Then loosen the bolt 360 degrees. Now torque the bolt to 59 ft-lbs. Then tighten an additional 125° using a torque angle meter.**

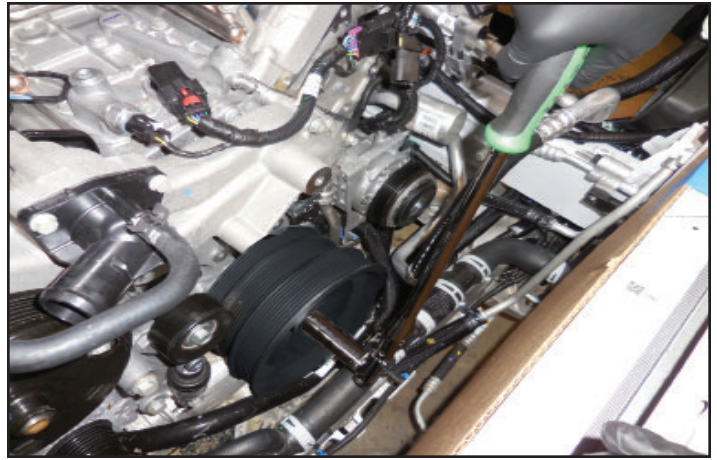

117. Gather all the provided tensioner hardware and brackets. **Apply Loctite 242 to the thread ends of all the bolts prior to installation** as shown with blue color in the photo. **Three of the bolts are shown with yellow arrows already installed in pulleys. They have Loctite 242 as well.** The three bolts shown with the red arrow are M8 x 40 mm. The two bolts shown with a blue arrow are M8 x 55 mm. The two bolts shown with a green arrow are M10 x 100 mm.

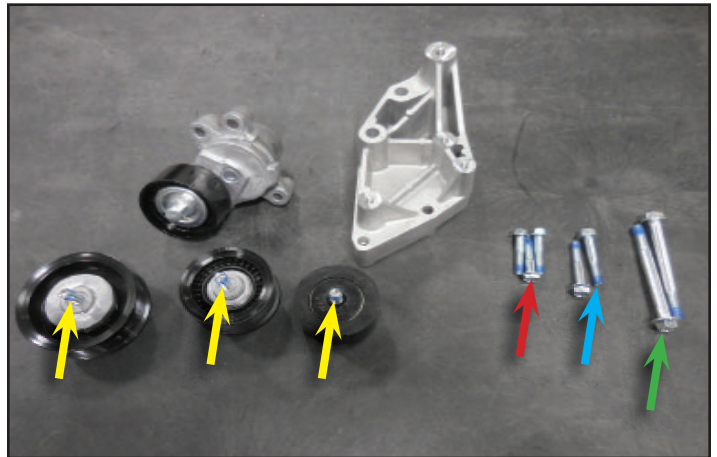

118. Disconnect the two harness clips shown with arrows in this photo using a small pry bar.

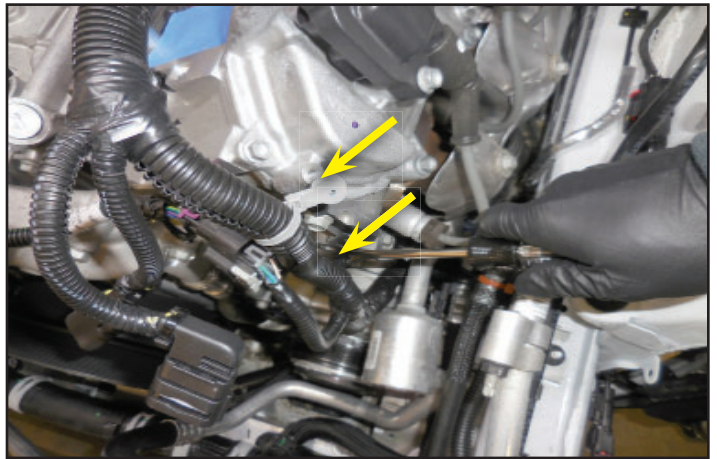

119. Remove the bolt shown with a 13 mm socket wrench. The ground wire that is secured with this bolt will be re-located in a later step. **This bolt will not be re-used.**



120. Install the two 100 mm long bolts with 15 mm heads in the locations shown with red arrows, and the two 55 mm long bolts with 12 mm heads in the locations shown with yellow arrows.

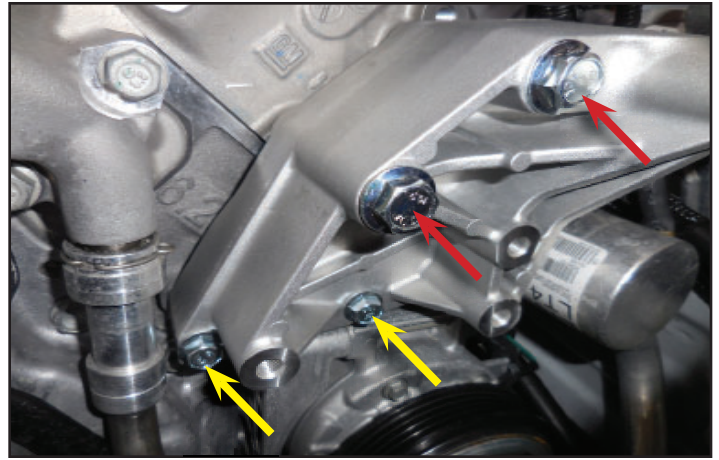

121. **Torque the bolts with 15 mm heads to 25 ft-lbs, and the two bolts with 12 mm heads to 18 ft-lbs.**



122. Unplug the wire connection shown, and re-route the wire around the back of the larger set of wires as shown with the yellow arrow.



123. Place the provided tensioner in the location shown on the new bracket and install the ground wire that was removed earlier to the location shown with a red arrow. The ground wire will sandwich between the bolt flange and tensioner. Install M8x40mm bolts at all the arrow locations, and tighten them using a 12 mm socket wrench. **Torque these three bolts to 18 ft-lbs.**

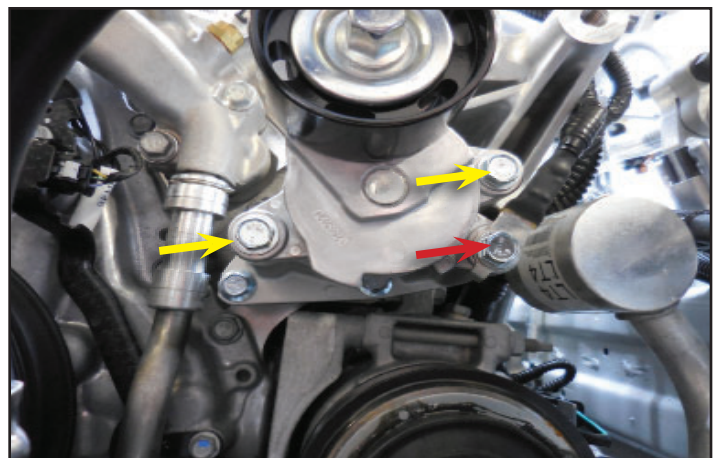

124. Place the provided larger ribbed pulley in the red arrow location using the provided bolt. The other smaller ribbed pulley goes in the yellow arrow location. The smooth idler pulley goes in the green arrow location. **Torque all three idlers to 25 ft-lbs.**

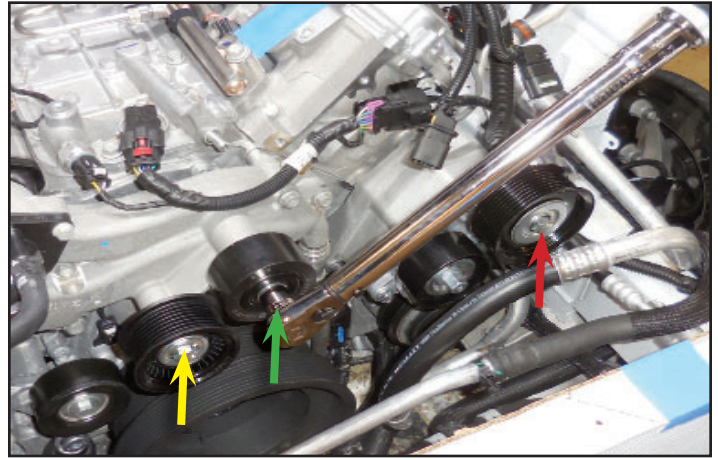

125. Remove the cardboard protection from the radiator back.

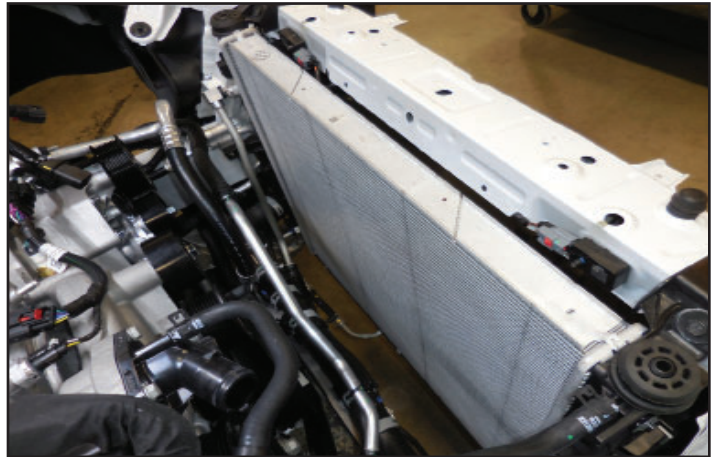

126. Install the fan shroud in the reverse order of removal. Make sure all lower tabs engage. Install the 2 upper bolts with 10 mm heads and the three bolts with 7 mm heads. Plug the electrical connection back in place at the top of the fan shroud and clip it back to the shroud. Also clip the lower transmission cooler line back in place.



127. Apply a thin layer of Lubriplate grease to the outside of the transmission cooler line prior to installing it in its original location. Install the OEM spring clip to secure the transmission cooling line. Slide the plastic ring cover over the spring clip once the connection has been properly secured.



128. Use a 24 mm socket and ratchet wrench to rotate the crank pulley clockwise as you have someone locate the air conditioning belt in place. Slip the belt fully around the crank pulley and pull/push the belt over the A/C pulley as you rotate. Make sure all ribs engage.



129. Rotate the tensioner shown with an arrow clockwise to allow the original belt to be re-installed.

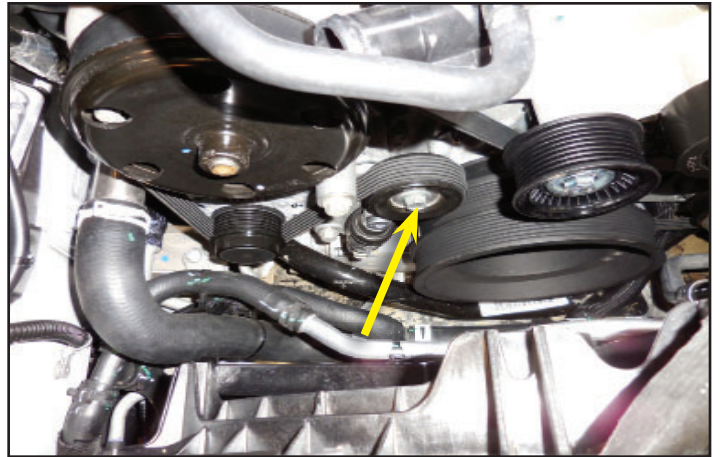

130. Apply a thin film of Lubriplate grease to the inner lip of the upper and lower radiator hoses.



131. Re-install the upper and lower radiator hoses. Use the mark you made earlier on the upper radiator hose to allow for proper orientation. Re-install the upper cover for the radiator using the three OEM plastic rivets.



Section 8: Coil Pack Removal, and Stud Installation

132. Unplug the 4 coil packs on the left side of the engine by first pulling back on the red locking tab, and then the connection can be pulled off (shown with a green arrow). Then unplug the spark plug wire (shown with a red arrow). Finally remove the two bolts (shown with yellow arrows) using a 10 mm socket wrench. Repeat this process to remove the 4 right side coil packs.



133. Once you have removed all the coil packs you can remove the valve covers. These will be modified in the next steps.



134. Remove the gaskets from the two valve covers. There is a tab at the corner that allows you to easily pull this gasket out.



135. Apply masking tape to all the inlets of the valve covers prior to cutting.



136. Tape the bottom surface as well.

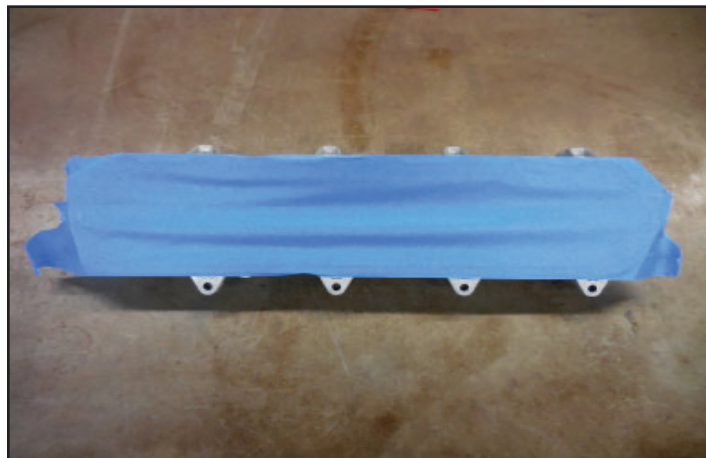

137. Gather the supplied wedges for trimming your valve covers. These may be another color.



138. Place the wedges on the bottom using the bolt holes to secure them in place.

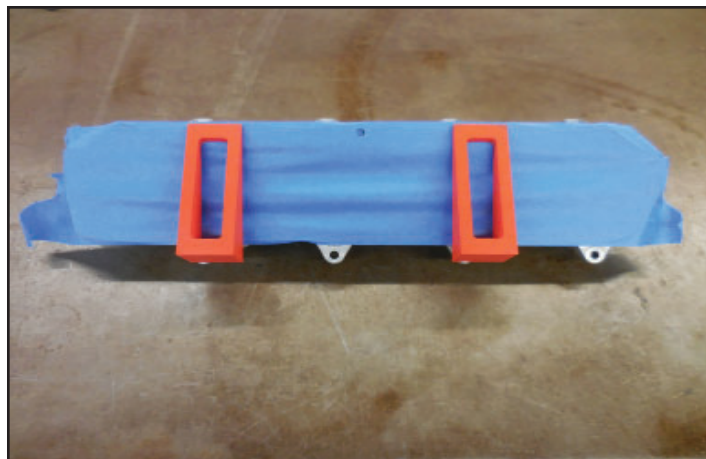

139. Ensure that the wedges sit flat against the bottom of the valve covers, and that they contact the band saw table and guide fence as shown here.

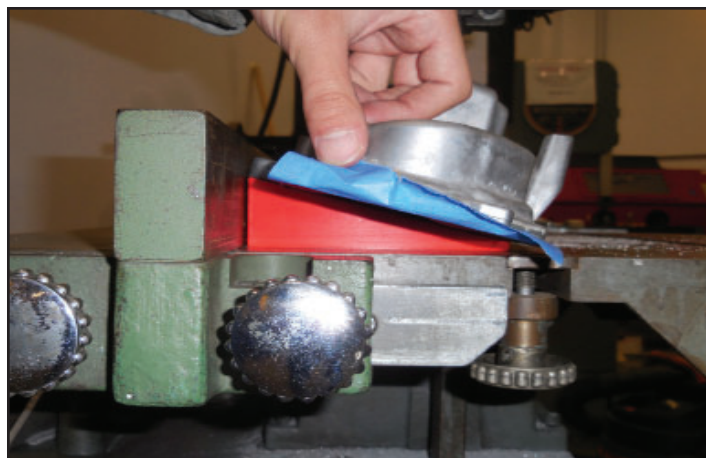

140. Cut each of the top coil pack mounts flush with the valve cover. You will have to stop the saw to reposition the wedges for each cut.



141. Once you have cut the upper coil pack mounts flush you will need to remove any sharp edges. Also thoroughly clean all the debris from the covers once you have removed the sharp edges.



142. Remove the masking tape. Clean out the debris using a solvent cleaning tank. Ensure that the covers are thoroughly clean and dry before installing them on the heads. Re-install the gaskets on both valve covers.

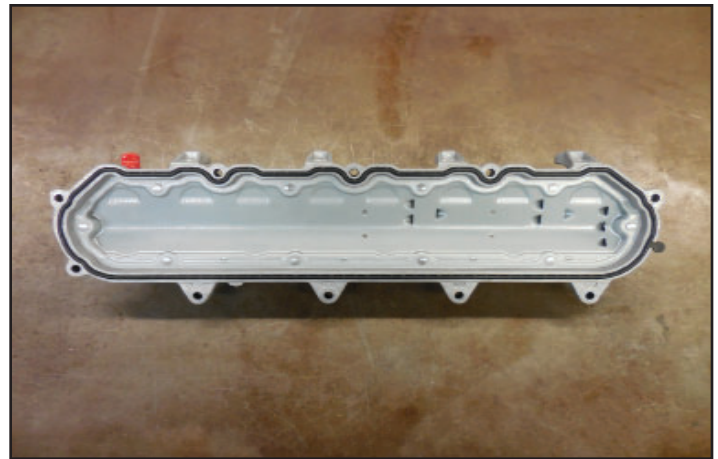

143. Gather the following bracket, nuts and spacers. You will need one set per side.

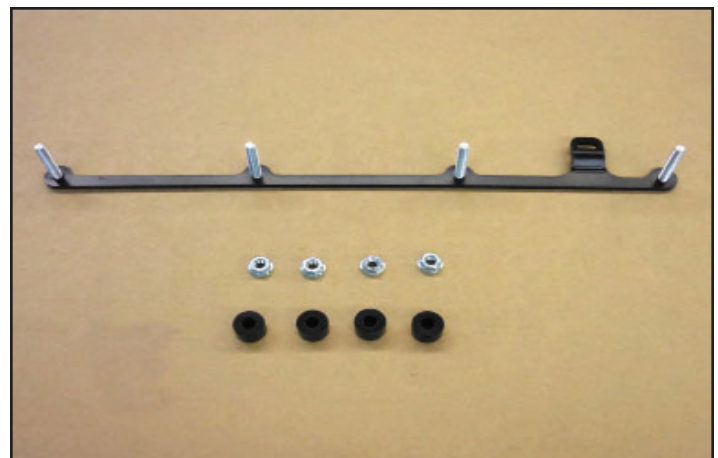

144. Install the spacers on the studs as shown.

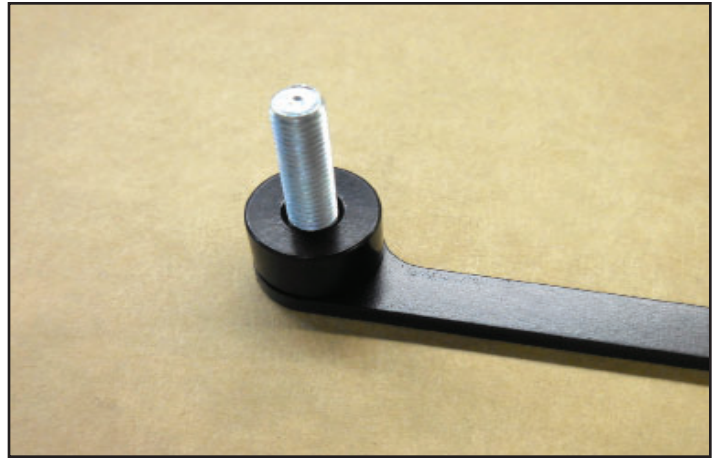

145. Install the coil covers with the supplied lower mount as shown using the provided nuts.

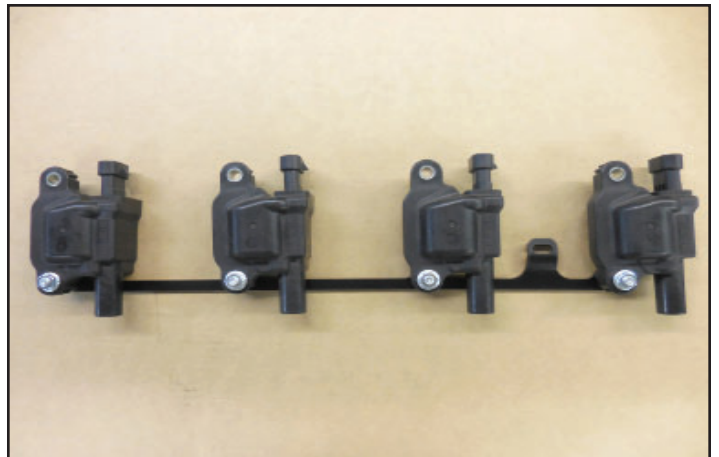

146. Use the OEM bolts at the red arrow locations to install the coils back on the valve covers that were just modified. This will shift the coil packs lower in the engine to give clearance for the supercharger. Install the provided M6x14mm bolt at the yellow arrow location. Repeat this process on the other valve cover.

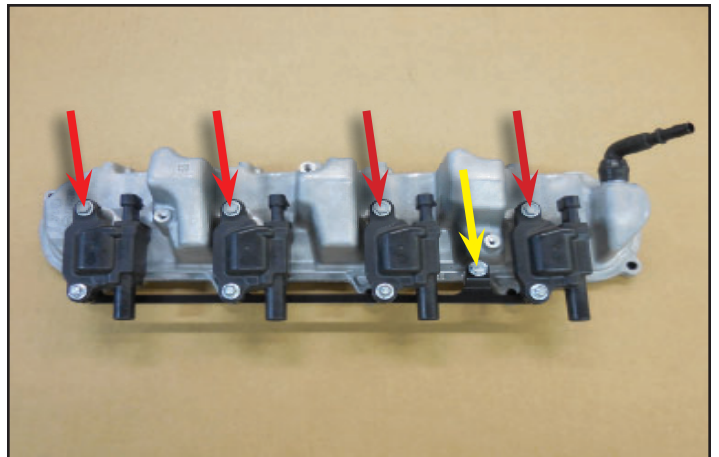

147. Reinstall the valve covers and carefully route the wires out of the way as shown here.



Section 9: Supercharger Preparation and Installation

148. Remove the 19 M6x30mm bolts around the perimeter of the lid and remove the lid. Also remove the four screws holding the Magnuson Supercharger Emblems to gain access the 4 bolt locations that will be fitted with M6x30mm bolts later.



149. Remove the 3 bolts holding the coolant manifold assembly at the front of the supercharger and pull the spigot out. Repeat this process on the other coolant manifold assembly.

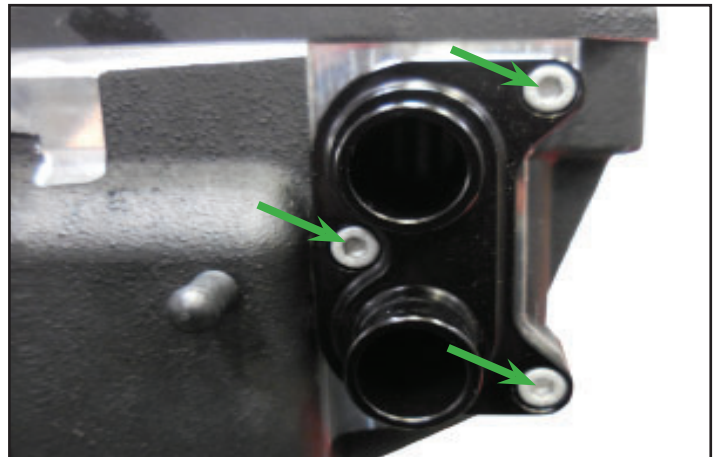

150. Remove the 6 bolts holding the charge air coolers inside the supercharger housing and pull the charge air coolers out. Carefully pull out the charge air coolers by hand. Pull evenly around the perimeter to disengage the seal.



151. Prior to installing the throttle body adaptor make sure that the O-ring is installed in the supercharger housing and throttle body adaptor. Install the stud and nut from the last step at the green arrow location. Ensure that the stud is protruding enough for the nut to have full thread engagement. Install the three M6x25mm bolts from the last step to the throttle body adaptor in the red arrow locations shown (the dashed arrow shows the bolt that is hidden from view) and **torque to 106in-lbs.**

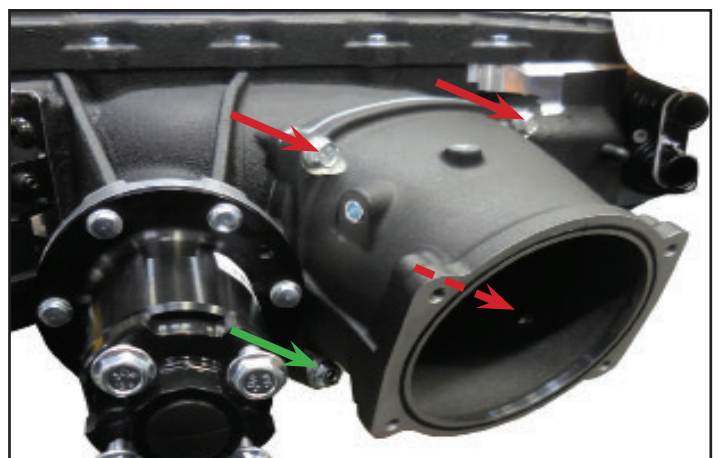

152. Remove the blue tape from the intake ports. Wipe down the intake port outer sealing surfaces with a rag coated with Tri-flow. Pull the coil harnesses to the sides to make clearance for supercharger installation. Ensure that there are no tools or other items left in the valley area before you install the supercharger.

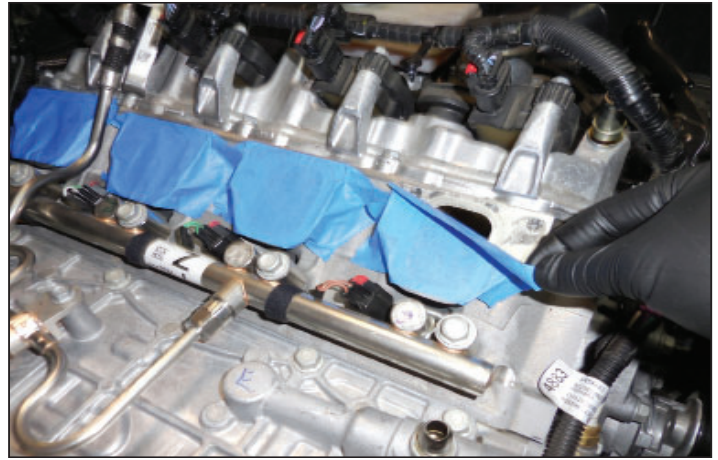

153. Install the provided seal washers shown with a blue arrow on 10 provided M6x30mm flange bolts. Once you have slid the washers on all the way to the heads apply a light coat of Lubriplate grease to their undersides. Finally **apply blue Loctite 242** to the ends of these bolts as shown



154. Have someone help you locate the supercharger into the manifold valley location. Install the bolts from the last step into the locations listed on the diagram at the back of this book. First finger tighten all bolts. Gradually work your way up to the torque specification listed while you follow the numerical order listed in the diagram. **Make 3 passes, slightly increasing tightening each time. Then make a final pass at 106 in-lbs following the torque sequence at the back of this book.**



155. Place rags on top of the supercharger to prevent any debris from falling inside the ports.



156. Gather the supplied MAP sensor wiring extension.



157. Install the MAP sensor wiring extension on the OEM plug.



158. Install the opposite side of the wire from the last step onto the MAP sensor at the left rear of the supercharger.



159. Gather the provided EVAP wire assembly shown.



160. Plug in the connector from the EVAP wire assembly (highlighted in green) to the OEM connector shown with the arrow here.

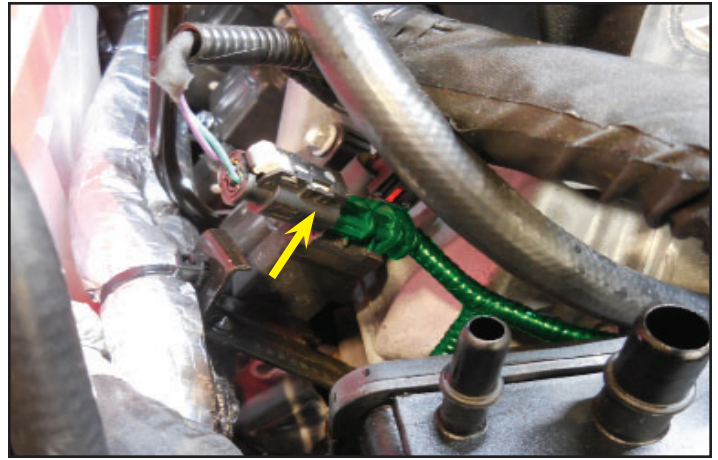

161. Route the longer wire from the last step to the opposite side of the engine routing it under the throttle body adapter as shown with the green dashed line. The shorter wire will run in the opposite direction towards the fuse box. Both of these connections will be plugged in later.



162. Gather the provided Mass Air Flow (MAF) breakout IAT harness shown. This will be installed in the next steps.



163. Remove 90 degree strain relief cover from the OEM MAF connector and install it over the connection shown on the provided MAF breakout IAT harness.



164. Plug in the provided breakout harness to the OEM MAF connection.

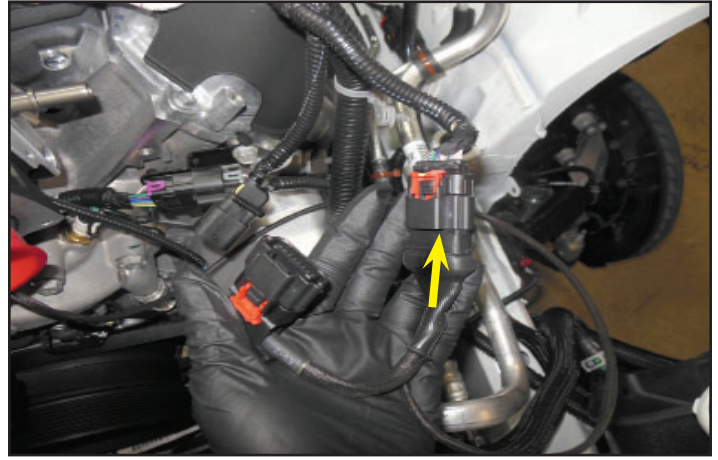

165. Route the breakout IAT connection under the supercharger inlet and plug it in where shown. The wire has been highlighted in green for clarity.



166. Secure the excess IAT wire with a provided cable tie in the location shown with an arrow. The MAF connection will be made later.



167. Connect the provided PCV hose assembly shown here to the PCV barb location that was modified earlier. **The 5" hose will attach to the barb on the valley cover. The black side of the PCV valve (shown with the green arrow) should face away from the barb on the valley cover. It is extremely important to orient the PCV valve properly to avoid engine damage.** Use a provided black spring clamp to secure this connection.



168. Connect the provided PCV hose line from the last step to the 90° hose barb shown at the air inlet.

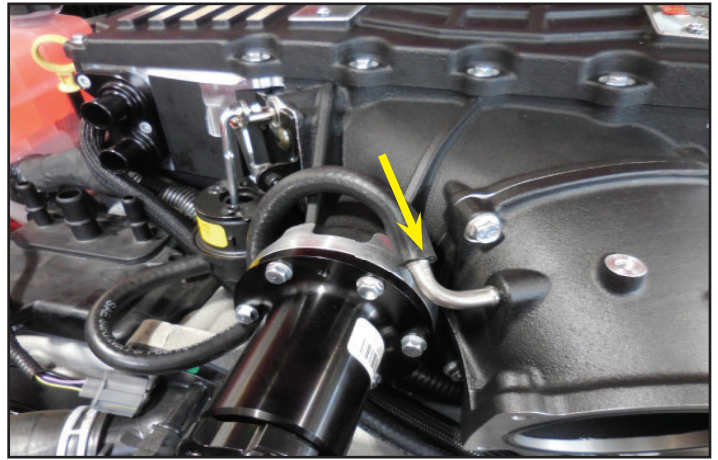

Section 10: LTR Installation, and Horn Relocation

169. Remove the 4 bolts holding the cross braces from the bumper impact bar located near the front radiator.

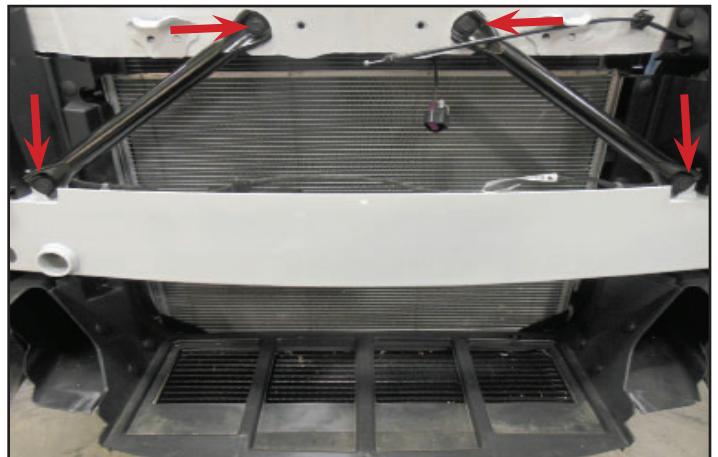

170. Remove the two plastic rivets shown with yellow arrows from both sides of the vehicle. These will not be re-used. Remove the breakaway tab cover shown with the red arrow. On the left side only, temporarily remove the rivet shown with green arrow.

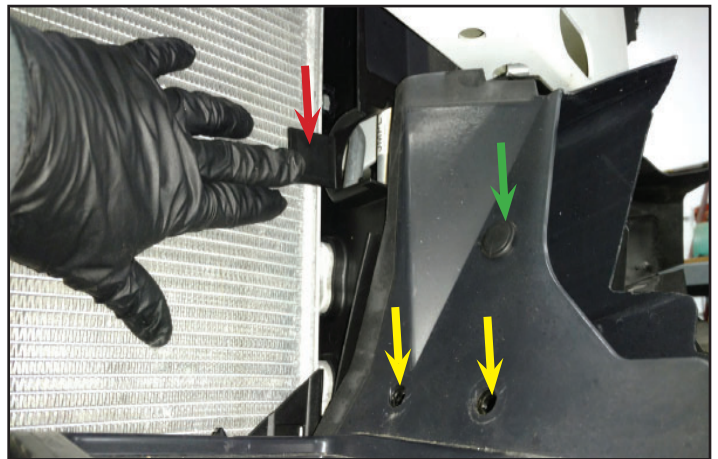

171. Remove the two plastic rivets shown with arrows holding the left side air deflector.

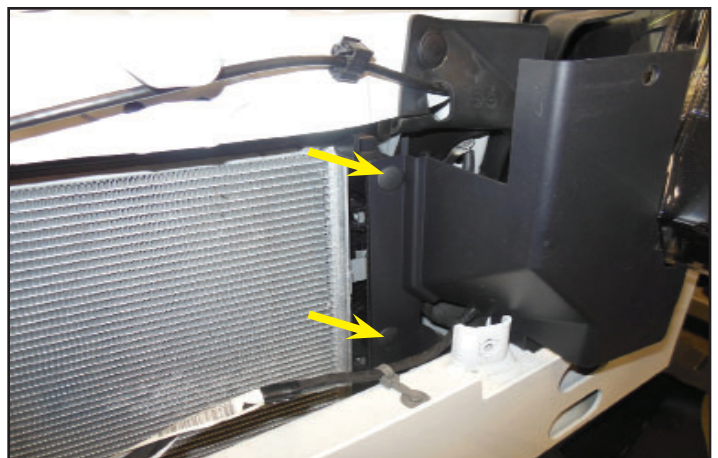

172. Remove the one plastic rivet hidden behind the deflector tab and located on top of the bumper impact bar.



173. Remove the deflector that just had the plastic rivets removed.



174. Remove the bolt holding the grounding wire shown with a green arrow. Also remove the retainer for the wiring harness shown with a yellow arrow.



175. Remove the plastic rivet shown with the yellow arrow.

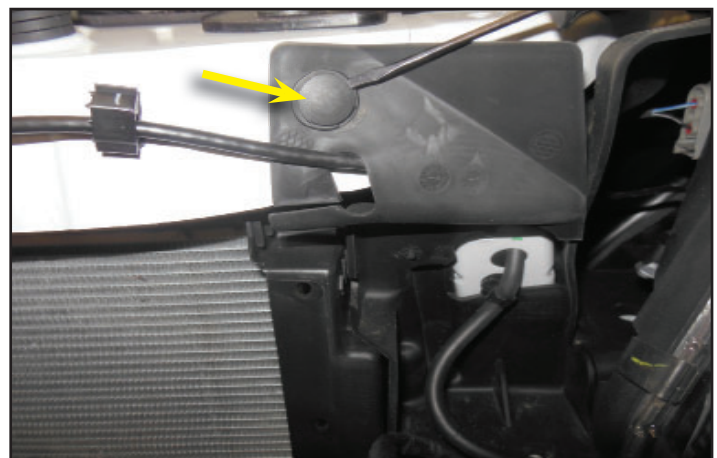

176. Remove the rubber cover shown.



177. Remove the three plastic rivets shown with the arrows. One is hidden behind the pump (shown with a dashed arrow). The rivets shown with the red arrows may be easier to remove from the back side which is shown in the next step.

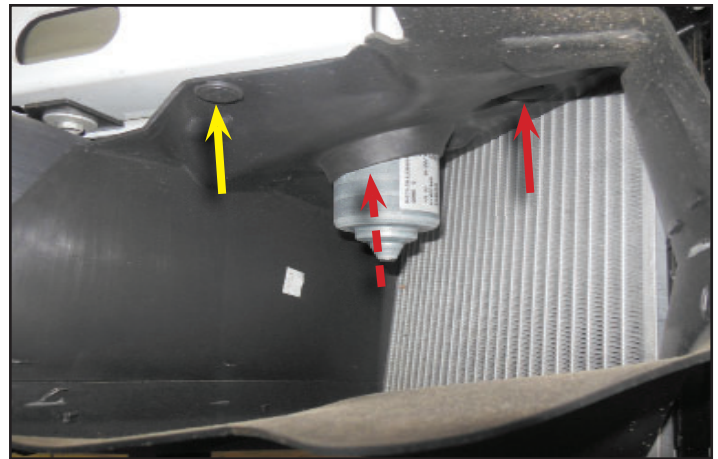

178. From the top side use a screwdriver to push down on the center of the rivets that are behind the pump (shown with red arrows). These were shown in the last step with red arrows as well.

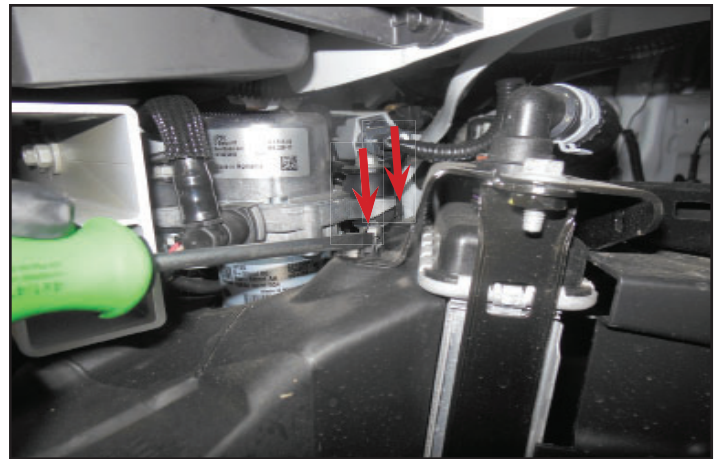

179. Remove the two rivets shown with arrows. Once these last two rivets have been removed slide the panel down to get it past the vacuum pump.

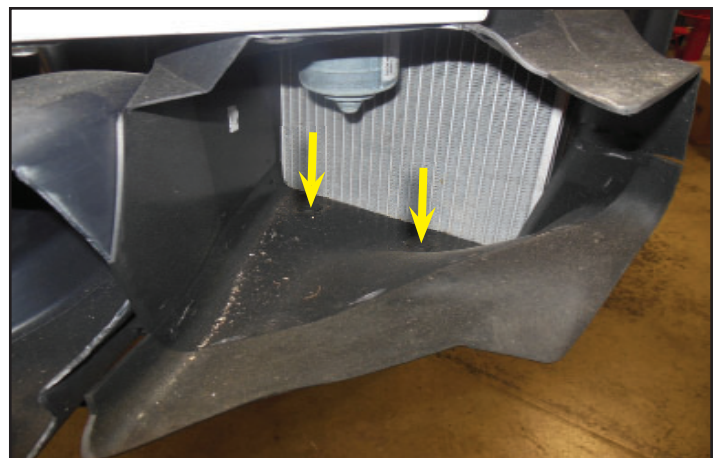

180. Pull out on the lower part of the panel and away to clear the two metal tabs shown with green arrows. Now slide the panel down to get it past the vacuum pump.

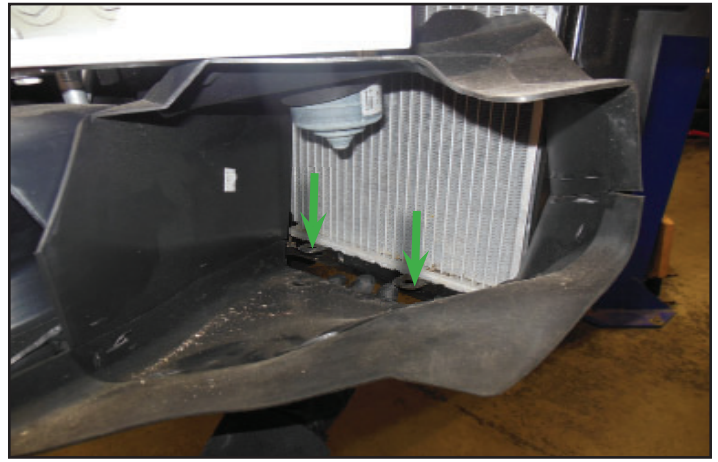

181. Remove the plastic rivet shown with an arrow. The brake air duct should now pivot out of the way.

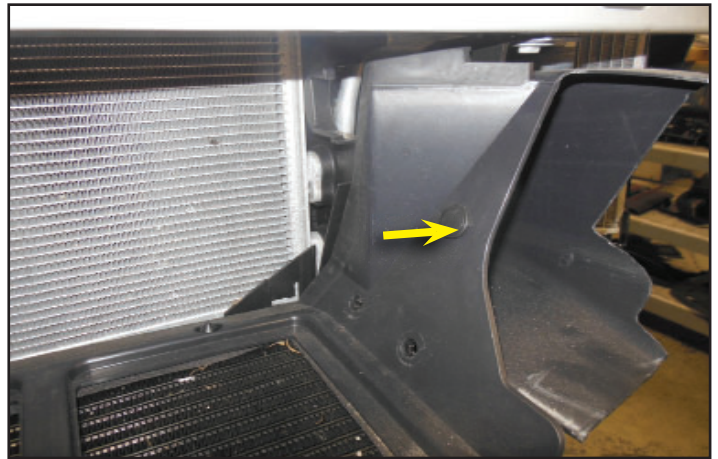

182. Remove the plastic rivet shown with an arrow. The brake air duct should now pivot down out of the way.



183. Remove the two plastic rivets shown with arrows.



184. Remove the wire harness retainer clip from the stud that holds the horns in place. Remove the stud/bolt securing the horns. Use a 10 mm deep socket.



185. Unplug the horn electrical connection shown.



186. Place cardboard in front of the radiator to protect it while drilling in the next step.

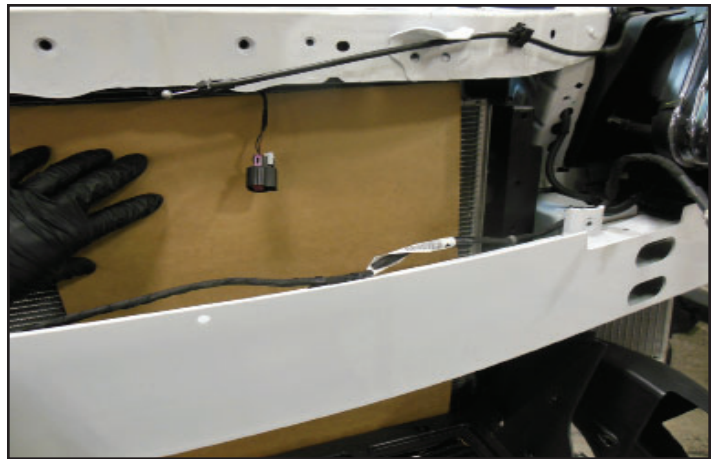

187. Drill a 1.5" hole in the upper forward most portion of the plastic side panel shown. This is located near the left side of the radiator. In the next step you will see a photo of the back side of this panel after drilling.



188. Here you can see the location for the hole in the last step. Clean the edges of the hole and then remove the protective cardboard.

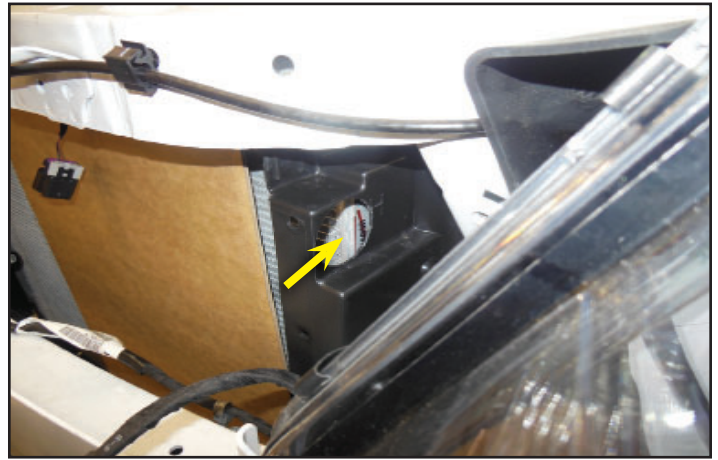

189. Gather the following provided items. The Low Temperature Radiator (LTR), two upper support brackets and 6 pop rivets are shown.

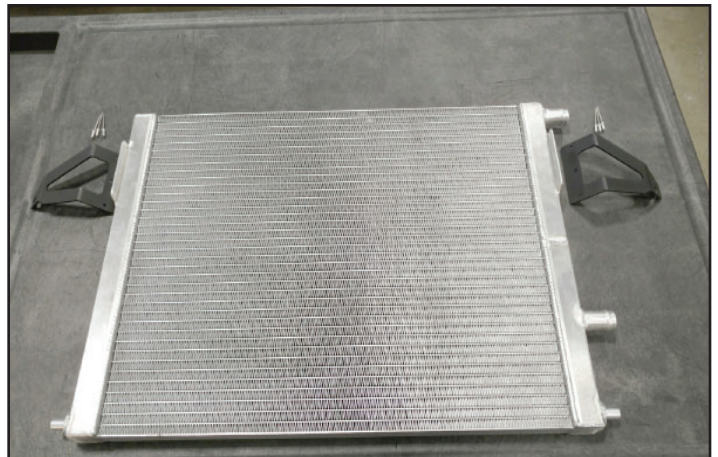

190. Secure the provided bracket shown with 3 pop rivets to the upper left side of the LTR near the upper spigot. Repeat this process to the other side of the LTR with the right bracket.

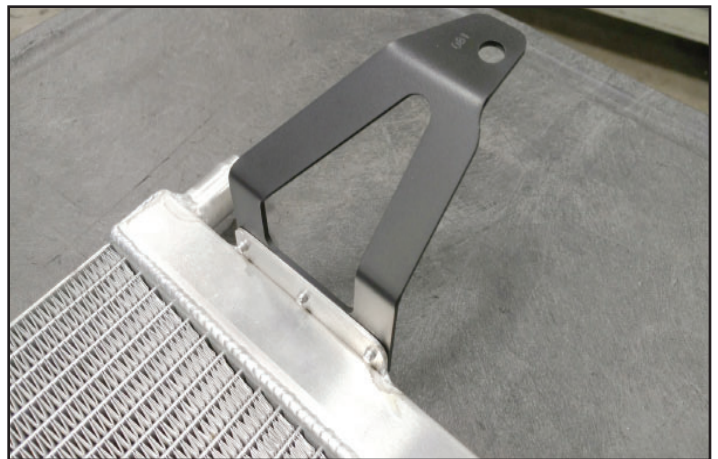

191. Insert the LTR from the top and make sure the upper spigot lines up with the 1.5" hole that was cut earlier. The lower spigot should line up with the lower "knock-out" panel.

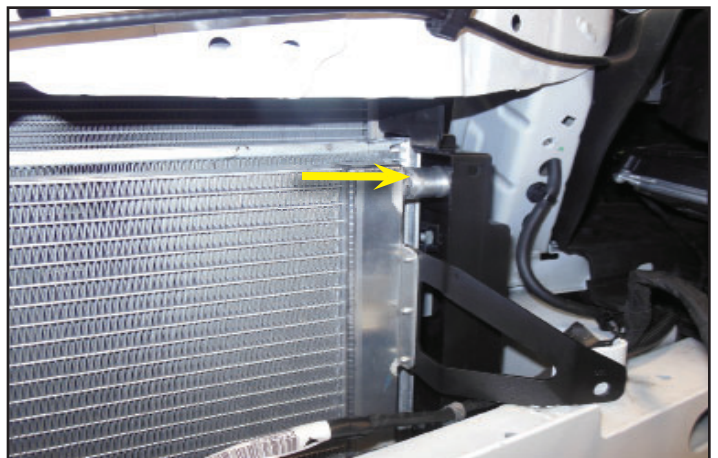

192. Attach the lower bracket for the LTR in the locations shown. Install the rubber bushings into the lower brackets. The studs of the brackets should slip into the two adjacent holes. The rubber bushings will mount to the bottom studs of the LTR. Repeat this process on the opposite side of the LTR. You will need to lightly trim some plastic near the right side bracket for clearance.



193. Loosely install the two provided nuts on the back side of the bracket just installed.



194. Locate the cross braces over the upper LTR brackets, and reinstall them using the OEM hardware. Do not fully tighten these yet.



195. With everything in place, make sure the LTR sits level and square. **Then tighten the lower bracket nuts and torque the upper bolts to 106 in-lbs.**

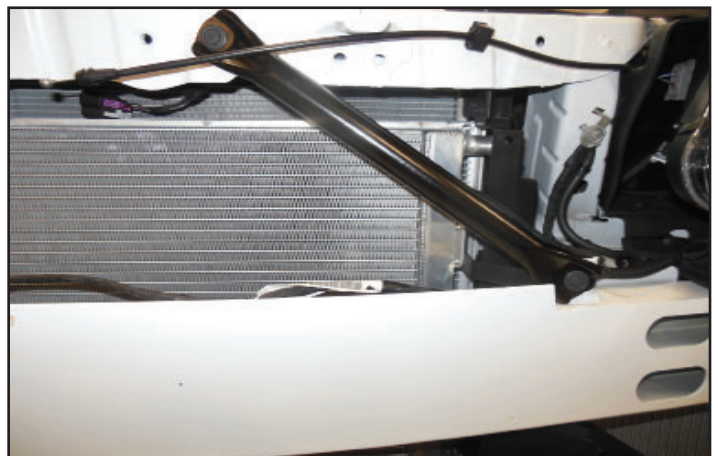

196. Cut the retaining clip from for the electrical wire that runs over the bumper crash bar near the horn assembly.



197. Cut the other electrical wire retainer located near the left and right angle brace on the bumper crash bar.

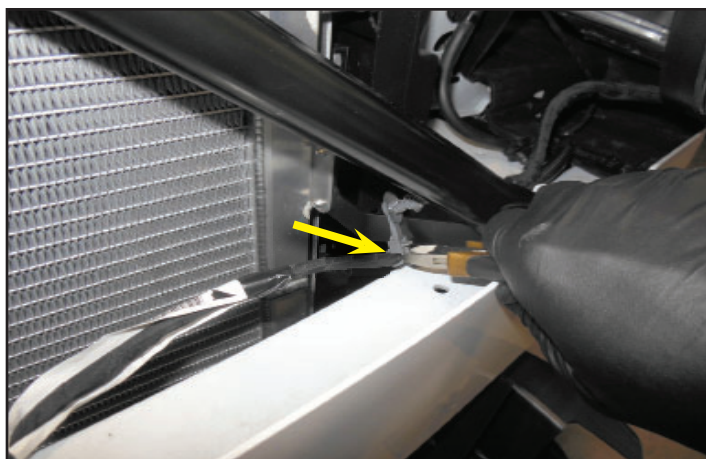

198. Cover the wire that you just removed the retainer from with the provided 1/4" plastic slit loom and tape the ends in place with electrical tape. Repeat on the right side.

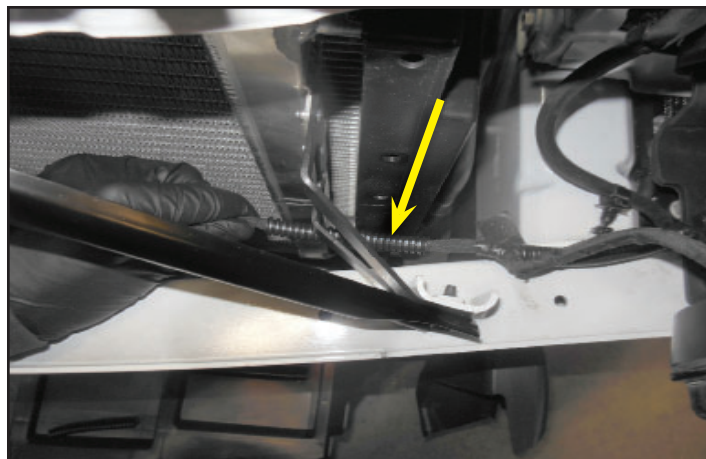

199. Place the provided cable tie with stud mount on the wire near the stud location for the horn. Make sure it is oriented as shown.



200. Replace the OEM horn bracket with the provided horn bracket shown.

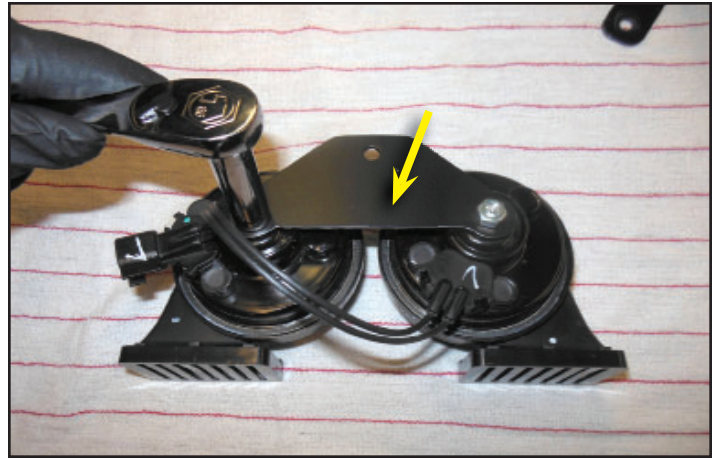

201. Install the horn assembly in the original location with the orientation shown. Make sure the gaps match (shown with red arrows)
Torque the bolt/stud to 106 in-lbs.



202. Press the cable tie connector that was installed earlier over the stud just installed.



203. Plug the electrical connection back into the horn assembly.



Section 11: Intercooler Pump Plumbing, and Electrical Connection

204. Remove the two OEM bolts located at the frame rail. This location will be used to hold a bracket in the following step. Use a 15 mm swivel socket or open end wrench to get into the tight area.

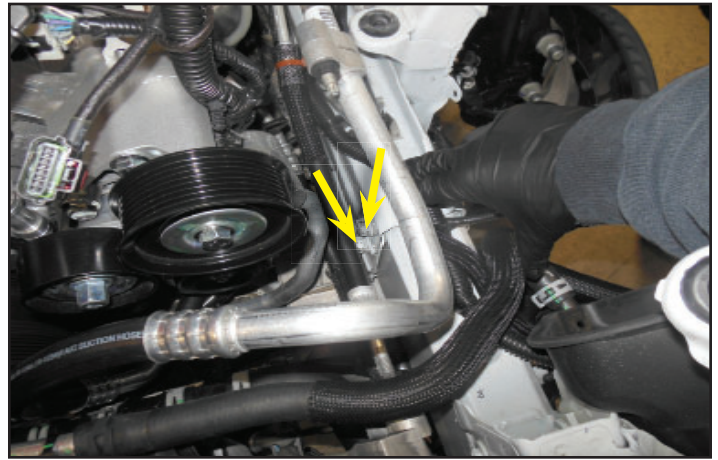

205. Install the provided bracket as seen here using the two OEM bolts that were removed in the previous step. The bracket is normally black but has been highlighted in green for clarity.

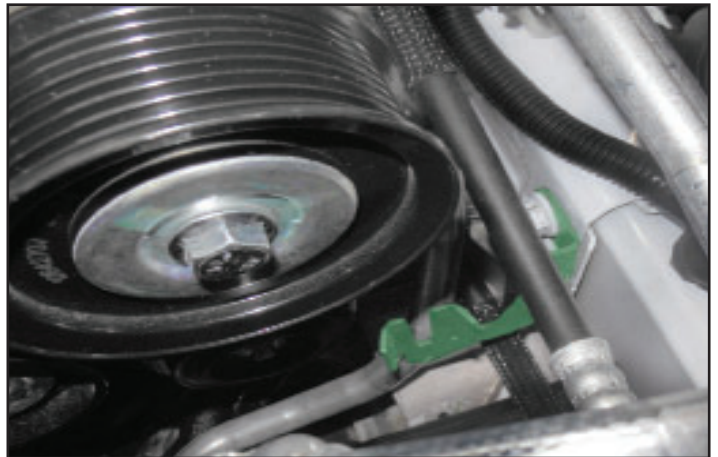

206. Gather the intercooler pump shown along with the rubber isolator. Slide the rubber isolator over the back of the intercooler pump and align it with the mounting slots (shown with arrows) on the opposite side of the pump discharge.



207. Slide the mounting slots of the rubber isolator for the intercooler pump over the bracket that was installed on the left fender well with the inlet for the pump facing up, and the discharge facing forward.



208. Use a 10 mm socket to remove the left and right upper radiator supports shown to allow clearance for the hose assembly in the next step.



209. Apply a thin layer of Lubriplate grease to both sides of the provided hose assembly shown. This will provide the connection between the lower LTR connection and the discharge of the intercooler pump.



210. Slide the straight piece of rubber hose through the gap between the vertical radiator support and the radiator, and rotate the end shown in hand down towards the lower LTR connection. Have a helper pull the top left corner of the radiator to the right. This will allow for the hardline to fit in place. It should line up with the pump discharge.



211. Continue to slide the hose assembly to the discharge of the intercooler pump. The hardline should sit just below the two bolts shown with arrows.

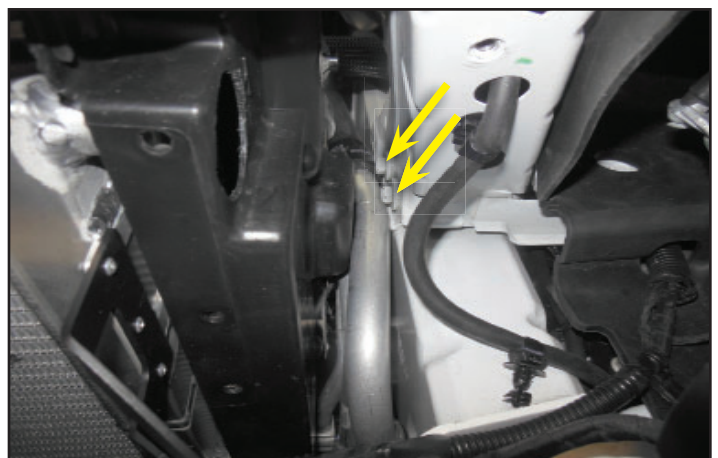

212. Connect the hose assembly end with the 90° fitting to the lower LTR connection and secure with a provided spring clamp (shown with an arrow).

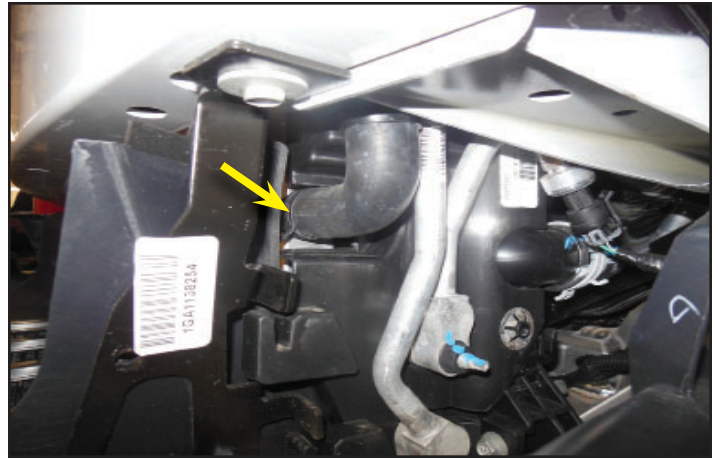

213. Connect the hose assembly end to the intercooler pump discharge using a provided spring clamp. First place the opened clamp over the hose then slip the hose/clamp over the pump spigot. **Now re-install the upper radiator supports.**

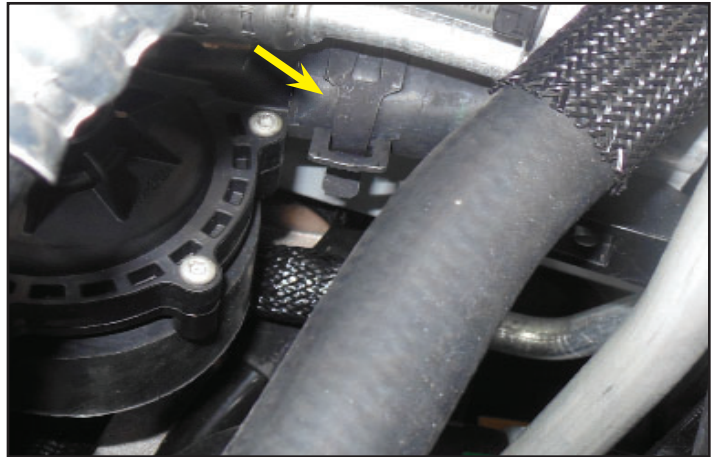

214. Connect the supplied intercooler reservoir to the provided bracket using the three provided bolts (shown with yellow arrows). **Torque the three bolts shown with the yellow arrows to 7 ft-lbs.** Install the bracket to the location shown incorporating it into the left strut tower brace (Shown with green arrows). **Torque the two bolts shown with the green arrows to 18 ft-lbs.**



215. Install the 90° end of the provided 3" x 20" hose to the intercooler pump inlet with a spring clamp (shown with a yellow arrow) and secure in place with a provided double wrap cable tie (shown with a green arrow). Place the supplied 1" piece of slit hose (shown with a red arrow) over the A/C hardline to allow the tie-wrap to grip it.

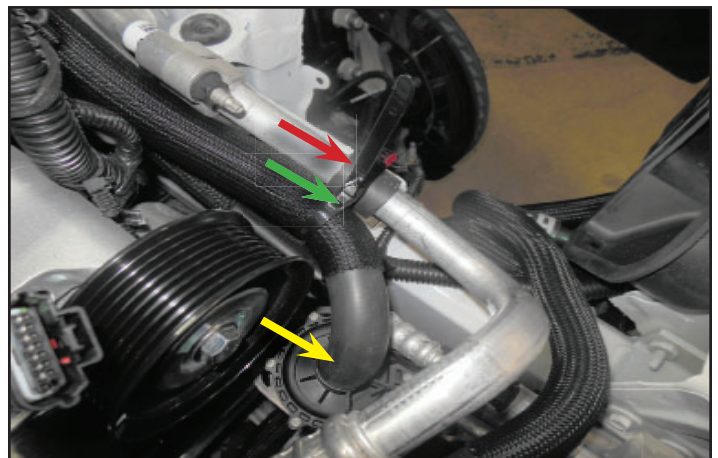

216. Install the other end of the hose shown in the last step to the reservoir at the yellow arrow location and secure with a provided worm gear clamp. Also secure the hose at the red arrow location.

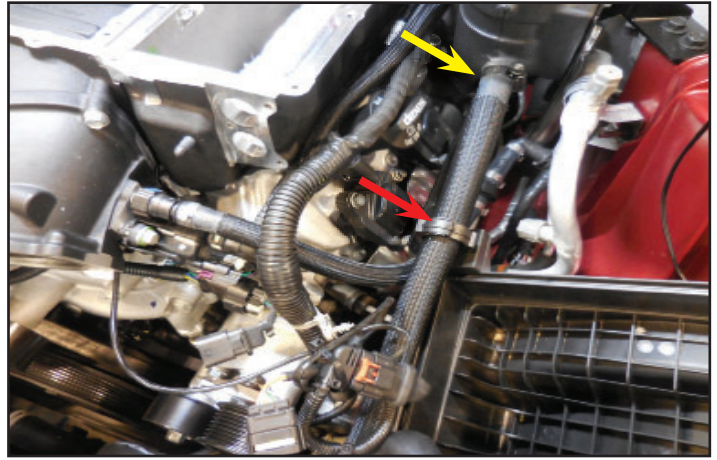

217. Apply a thin layer of Lubriplate grease to the inner rubber of the hose assembly shown. This will be used to connect the upper LTR spigot to the CACs.



218. Connect the 90° hose assembly from the last step to the upper LTR spigot with a provided spring clamp (shown with an arrow). This will go through the 1.5" hole that was drilled earlier.

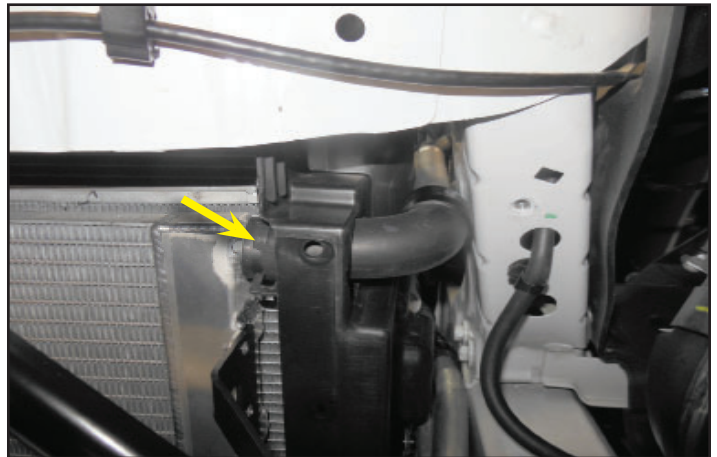

219. Replace the OEM bolt on the EVAP solenoid with the provided M6 x 25 mm bolt shown with the green washer in this image.



220. Apply a light coat of Lubriplate grease to the O-ring on the EVAP solenoid.



221. **Install the EVAP solenoid in the location shown and torque to 106 in-lbs.** Also plug in the electrical connection to the EVAP solenoid.



222. Install the EVAP line shown. One side connects to the metal hose line behind the supercharger (shown with a yellow arrow).

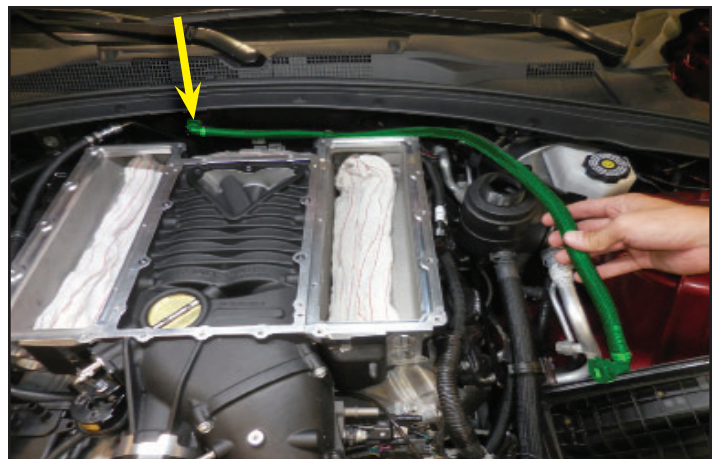

223. The other side of the EVAP line with the white clip connects to the EVAP solenoid.



224. Install the provided brake booster hose shown from the connection near the left fender well to the rear port on the supercharger inlet.

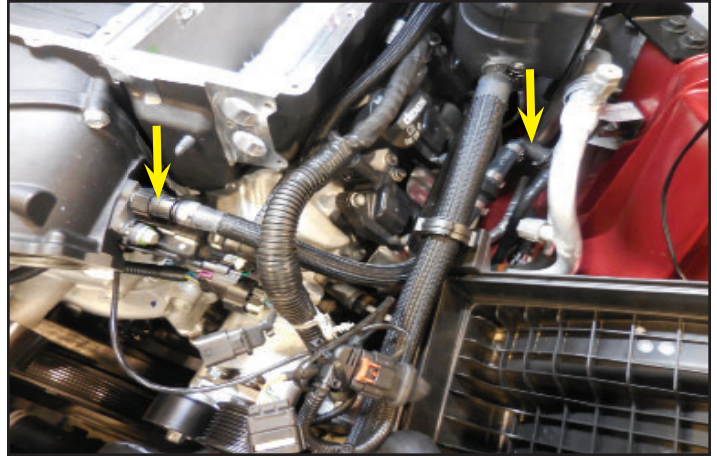

225. Remove the terminal cover on the back of the fuse box. There are two clips on either side of this cover that must be disengaged prior to removal.



226. Here is the cover from the previous step being removed.



227. Loosen the two nuts holding the fuse box in place. These are shown with arrows in the image. They do not need to be removed.

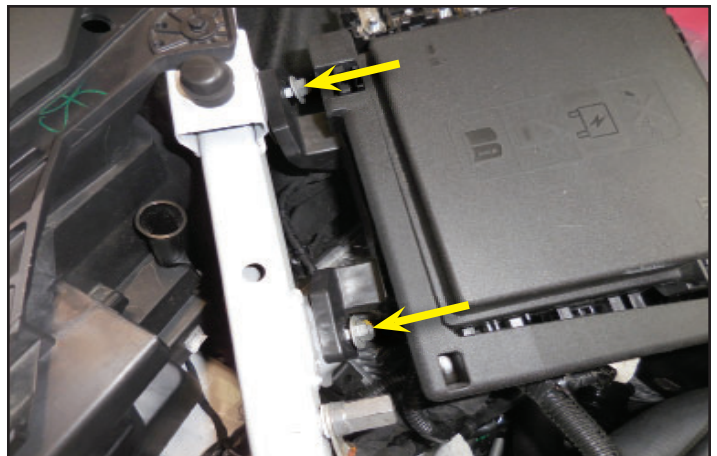

228. Gather the bracket shown in the photo. The front slot shown with the yellow arrow will be loaded onto the front stud just loosened behind the fuse box in the last step. This bracket goes between the fuse box and fender rail.

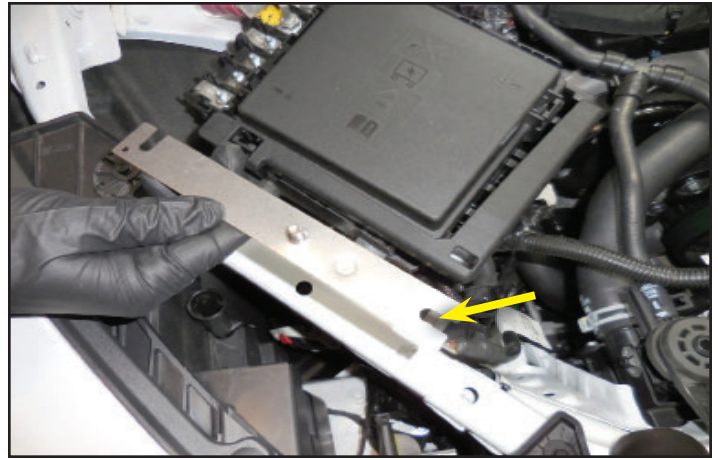

229. Here the front slot of the bracket from the last step is being installed (shown with the green arrow) behind the box at the front mounting stud. The slot towards the back will drop straight down into the rear stud location on the fuse box (shown with the yellow arrow).



230. Retighten the two nuts that hold the fuse box in place.

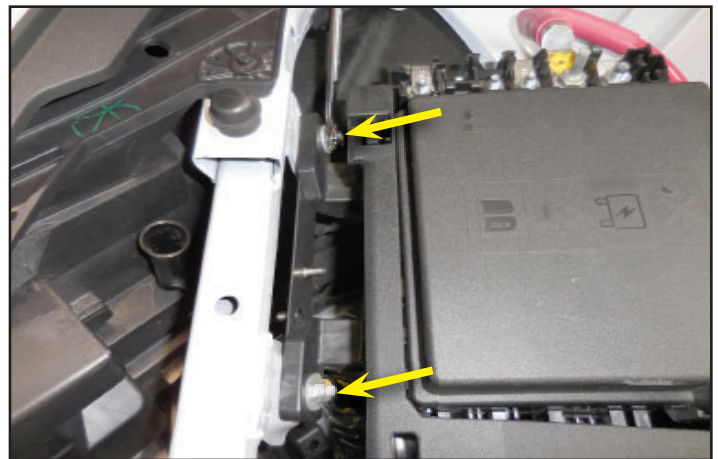

231. Gather the provided relay wiring assembly. The connections have been labeled.

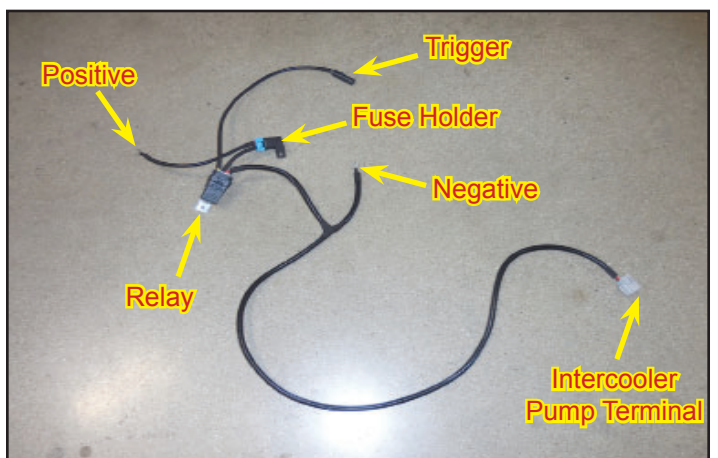

232. Route the intercooler pump terminal shown with an arrow under the fender rail. The wire has been partially highlighted in green for visual clarity.



233. Mount the relay under the fender rail and to the stud on the bracket that was installed behind the fuse box using the mounting hole shown here with an arrow and a provided nut.



234. Here a socket wrench is being used to tighten the provided nut to secure the relay from the previous step in place.



235. Route the fuse holder from the relay wiring assembly to the opposite side of the bracket mounted behind the fuse box. Remove the cover to allow installation of the provided 15 amp fuse.



236. Here is a photo of the 15 amp fuse installed. Replace the fuse cover, and mount the fuse cover to the stud location shown with an arrow.

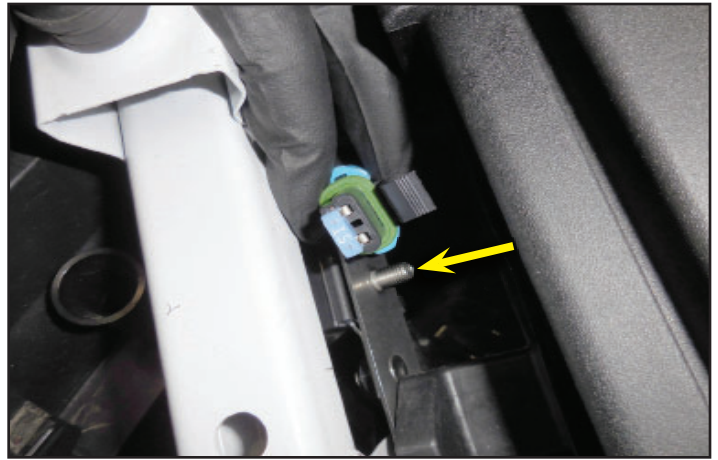

237. Tighten the fuse cover in place with a provided nut.



238. Route the positive lead of the relay wiring assembly to the back of the fuse box and attach it to the terminal shown with an arrow using a provided nut.

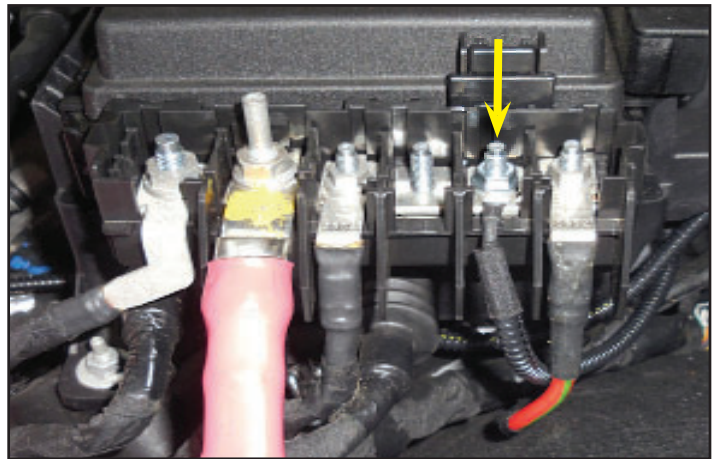

239. Route the trigger wire under the fuse box until it reaches the location shown with an arrow.



240. Connect the trigger wire to the EVAP wire connector that was installed earlier at the front of the supercharger.



241. Secure the wire connection made in the last step to the hose shown with a cable tie. Trim off the excess cable tie once it has been secured.



242. Reinstall the terminal cover on the fuse box.



243. Install the ground wire lead to the OEM location shown. **Do not move the existing ground.** Place the ground lead of the relay wiring assembly on top of the OEM terminal and tighten the OEM nut.



244. Route the power wire for the intercooler pump as shown by the green highlighted area. Secure in place using two provided cable ties shown with arrows in this image.

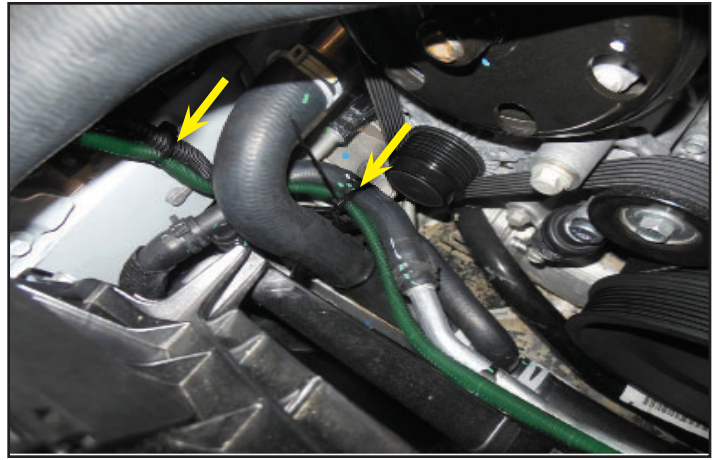

245. Route the power wire for the intercooler pump under the steel tube shown, and cable tie it to that same tube in the two locations shown with arrows.

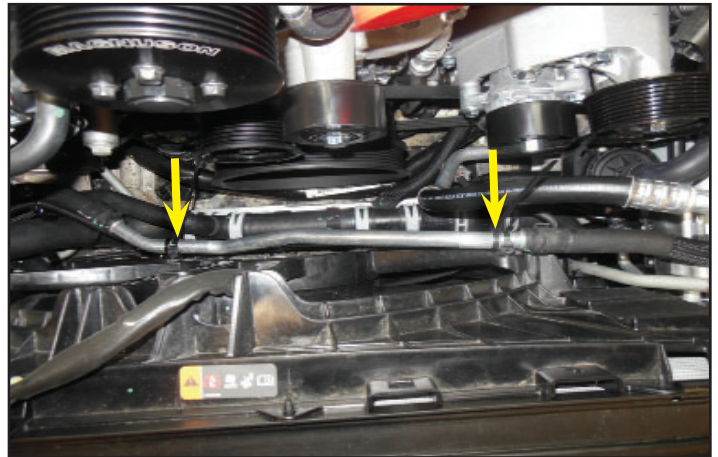

246. Plug the connector from the power wire you routed in the last steps into the intercooler pump electrical terminal on the underside of the pump.

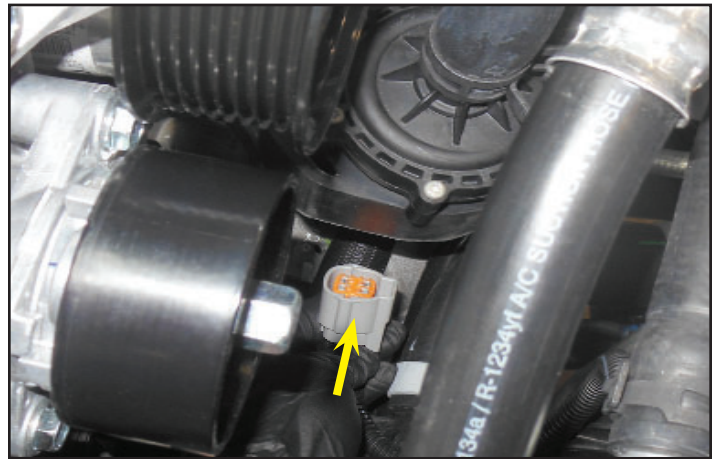

Section 12: CAC Installation

247. Remove the rags that were installed over the intake ports earlier.



248. **Apply Loctite 242** to the M5 bolts that were removed from the charge air coolers and the coolant manifolds and re-install these items in the locations shown in the next steps.



249. Reinstall the two charge air coolers and secure with 6 M5x12mm button head bolts from the last step.



250. Install 3 M5x16mm socket head bolts from two steps ago into the coolant manifold assembly shown. Repeat on the other coolant manifold.

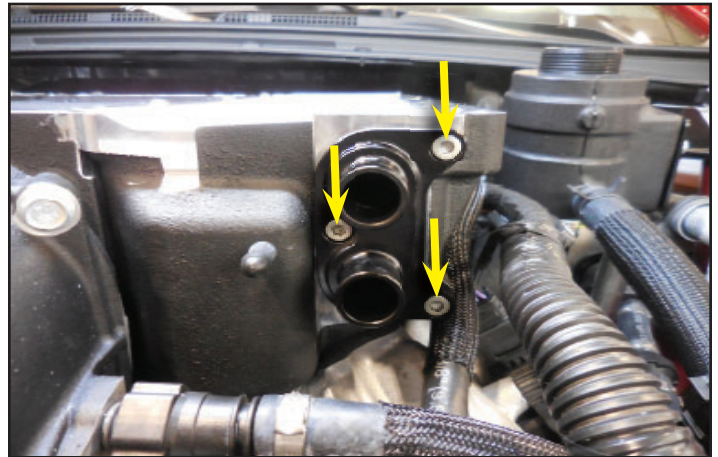

251. Install the 90° hose shown with the two arrows. Pass this hose under the pulley and inlet. This will connect at the lower charge air cooler spigot, and the “Y” connector on the other side.



252. Use hose clamp pliers to install the spring clamp at the coolant manifold spigot.



253. Connect the other two provided spring clamps at the arrow locations. The hoses are highlighted in green.



254. Gather the provided hose assembly highlighted here in green. Install the hose assembly from the last step and secure it at the two yellow arrow locations with two provided spring clamps. Use a worm gear clamp to secure the hose at the red arrow location at the back of the reservoir.



255. Install the hose end for the lower charge air cooler connections at the upper hardline going to the front Low Temperature Radiator and secure with a provided spring clamp.

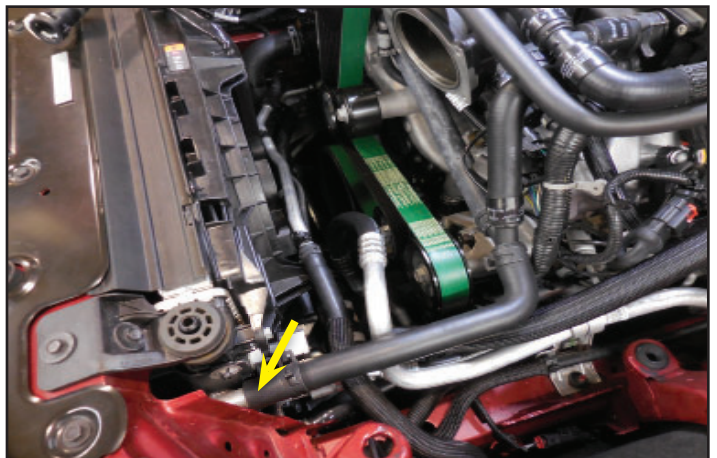

256. **Apply Loctite 242** to the 19 M6x20mm bolts that were removed from the lid and 4 more M6x30mm bolts that were provided and re-install the lid.

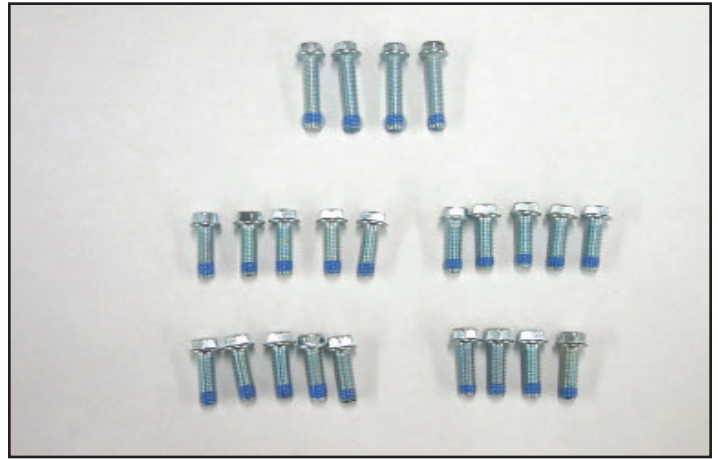

257. Place the lid on the supercharger and reinstall the hardware with Loctite 242 that were prepped in the last photo. Leave out one M6x20mm bolt in the location shown with the arrow. This location will incorporate an Adel hose clamp. The four M6x30mm bolts are for the center lid locations.



258. Place a provided M6 washer in the corner lid location shown.



259. Install the provided Adel clamp around the fuel line.



260. Install the last provided M6x20mm bolt in the corner lid location through the Adel clamp and washer that were just installed.



261. **Torque these 23 lid bolts to 106in-lbs following the order for the lid given at the back of this manual.**



262. Rotate the supercharger pulley by hand to ensure that it spins freely.



263. Gather the provided Magnuson Supercharged badges and M4x8mm bolts. Application of the adhesive backing from the two provided Magnuson Supercharged badges is optional. Be aware that these badges will be difficult to remove once the adhesive has been applied. Install the badges using the provided bolts.



264. Use a belt tensioning wrench, or other suitable socket and wrench to provide slack in the belt to install it according to the routing diagram given at the back of this manual. Rotate the supercharger tensioner counter-clockwise to provide slack. It is easiest to install the last portion of the belt at the smooth idler shown with the arrow.



265. Install the throttle body to the supercharger inlet using the OEM bolts. **Torque these four bolts to 106 in-lbs.**



266. Then plug in the electrical connection to the throttle body.

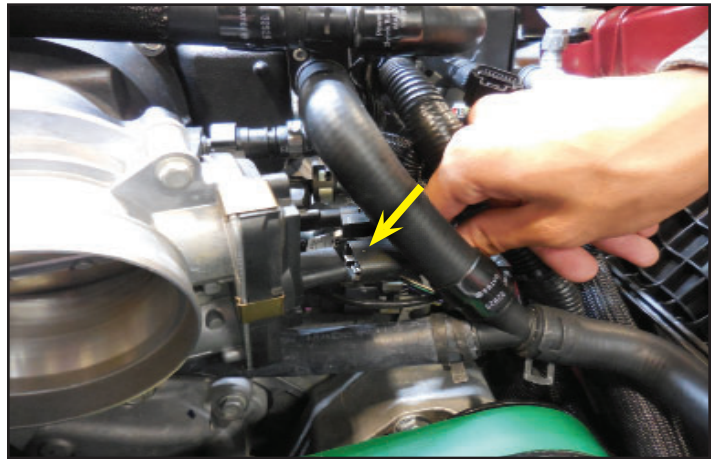

267. Ensure that the air filter is clean before installation. Install the OEM airbox and filter along with the provided rubber air duct. Use the two provided hose clamps to tighten the air duct in place.



268. Plug in the MAF sensor connector.

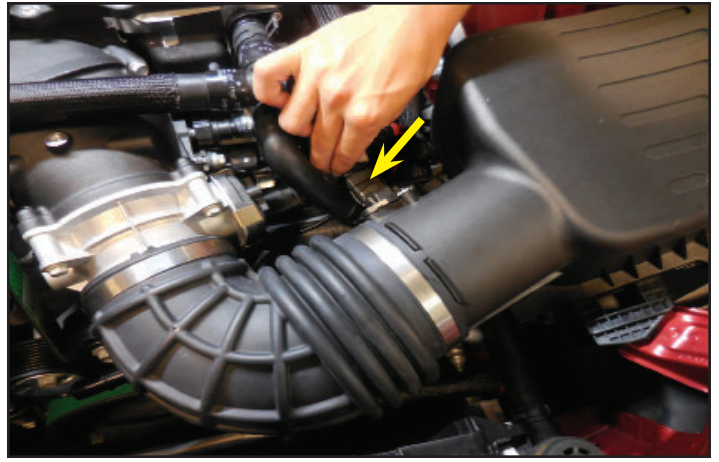

269. Connect the right side OEM vent hose shown at the two arrow locations.

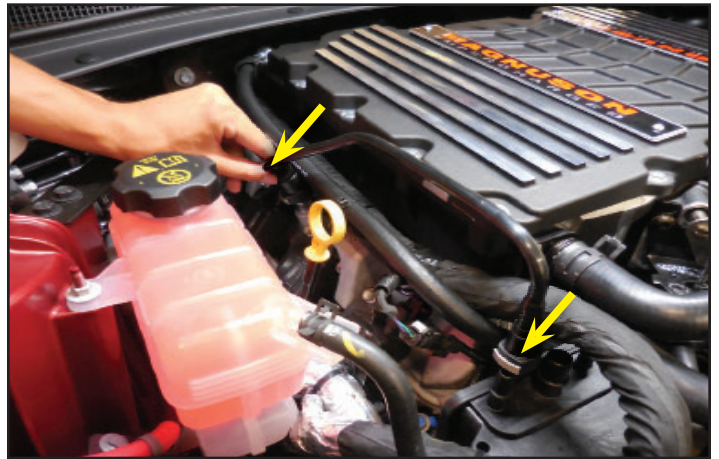

270. Install the provided vent hose to the arrow location. The opposite end will be connected in the next step.

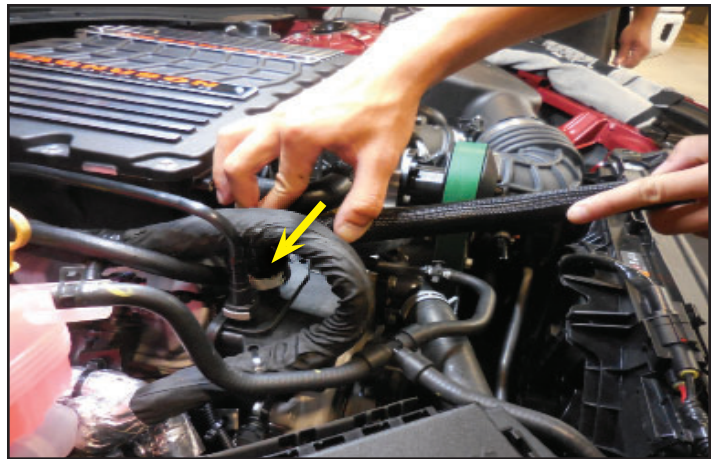

271. Connect the opposite end of the hose from the last step to the rubber air duct.



272. Re-connect the OEM vent hose at the left valve cover.

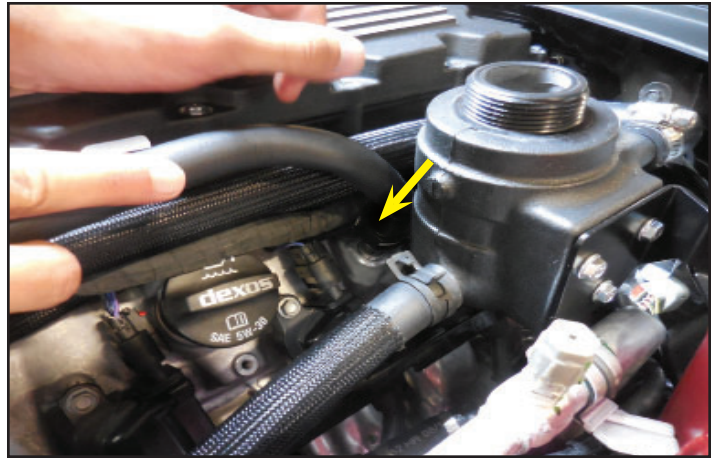

273. Connect the opposite end of the hose from the last step at the original arrow location.

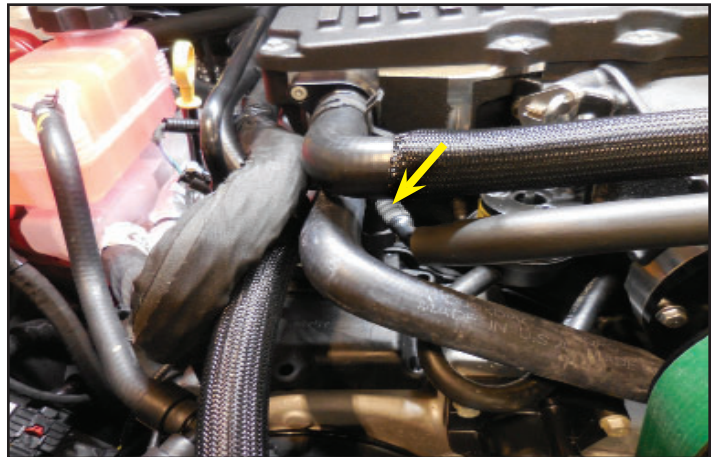

274. Here is the routing of the hose from the last two steps highlighted in green.



275. Install the Adel clamp at the location shown to secure the OEM vent hose using a provided Adel Clamp and M6x8mm bolt.



Section 13: Final Assembly and Testing

276. Re-install the hood latch ensuring the alignment marks line up. **Torque to 18 ft-lbs.**



277. Cut the cover shown at the dashed line location. This is the narrowest area. Only the section to the right of the dashed line will be used.

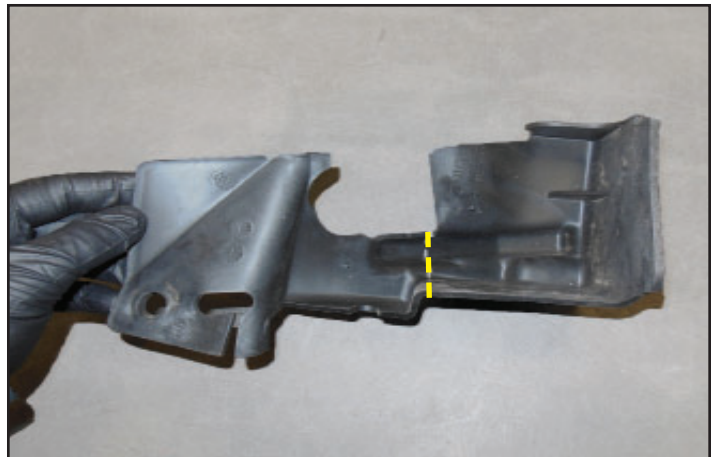

278. Install the cut section from the last step back into its original location.



279. Secure the ground wires in their original locations.



280. Trim the upper plastic rivet shown down by .25" for clearance, and then reinstall the panel shown. Also re-install the left brake duct at this time using the three plastic rivets that were removed.



281. Connect the battery and tighten with 10 mm wrench.



Make sure that you have followed step #1 in this manual to load the proper supercharger calibration to your vehicle's ECM.



282. Re-fill the radiator reservoir with the original coolant if it is clean enough. Otherwise use the manufacturers recommended coolant mixture.



283. Fill the intercooler system with the vehicle manufacturer recommended coolant mixture. Have an assistant temporarily key vehicle on to accessory mode (**Do Not start the vehicle**) to turn the pump on. Key vehicle off after 5 seconds. Fill reservoir full again and continue this process until fluid is circulating. At this time check your intercooler system, and fuel system for leaks. After you have filled your intercooler system, and verified the connections are leak free, reinstall headlights, fascia, and grill following steps shown in **Section 2** in reverse order.



284. Reinstall wheels and torque to manufacture's specifications. This can be found in the owners manual.



285. Start the vehicle for 5 seconds and shut it off. Check for fuel leaks and supercharger belt alignment. Check the intercooler reservoir level. Now start your engine and let it run for a few minutes to let it get to operating conditions. Let the engine cool down, and check all your levels again.



286. Test drive vehicle for the first few miles under normal driving conditions. **Do not perform any wide open throttle runs.** Listen for any noises, vibrations, engine misfire or anything that does not seem normal. The supercharger does have a slight whining noise under boost conditions, which is normal. Check & bleed the charge air cooler reservoir as needed. After the initial test drive gradually work the vehicle to wide open throttle runs, listen for any engine detonation (pinging). If engine detonation is present let up on the throttle immediately. Most detonation causes are low octane gasoline still in the tank.



If you have questions about your vehicles performance, please check with your installation facility.

After you finish your installation and road test your vehicle, please fill out the warranty registration. This can be found on our website.

Appendix

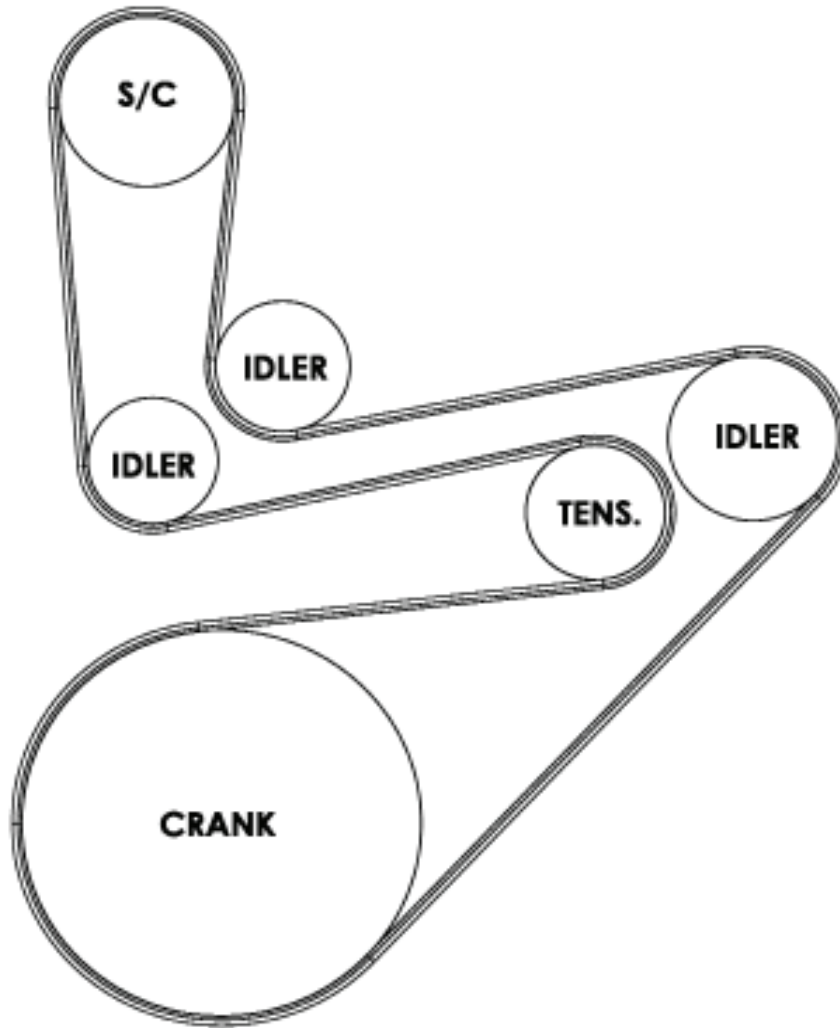

Supercharger Belt Routing
Diagram

Torque Specifications

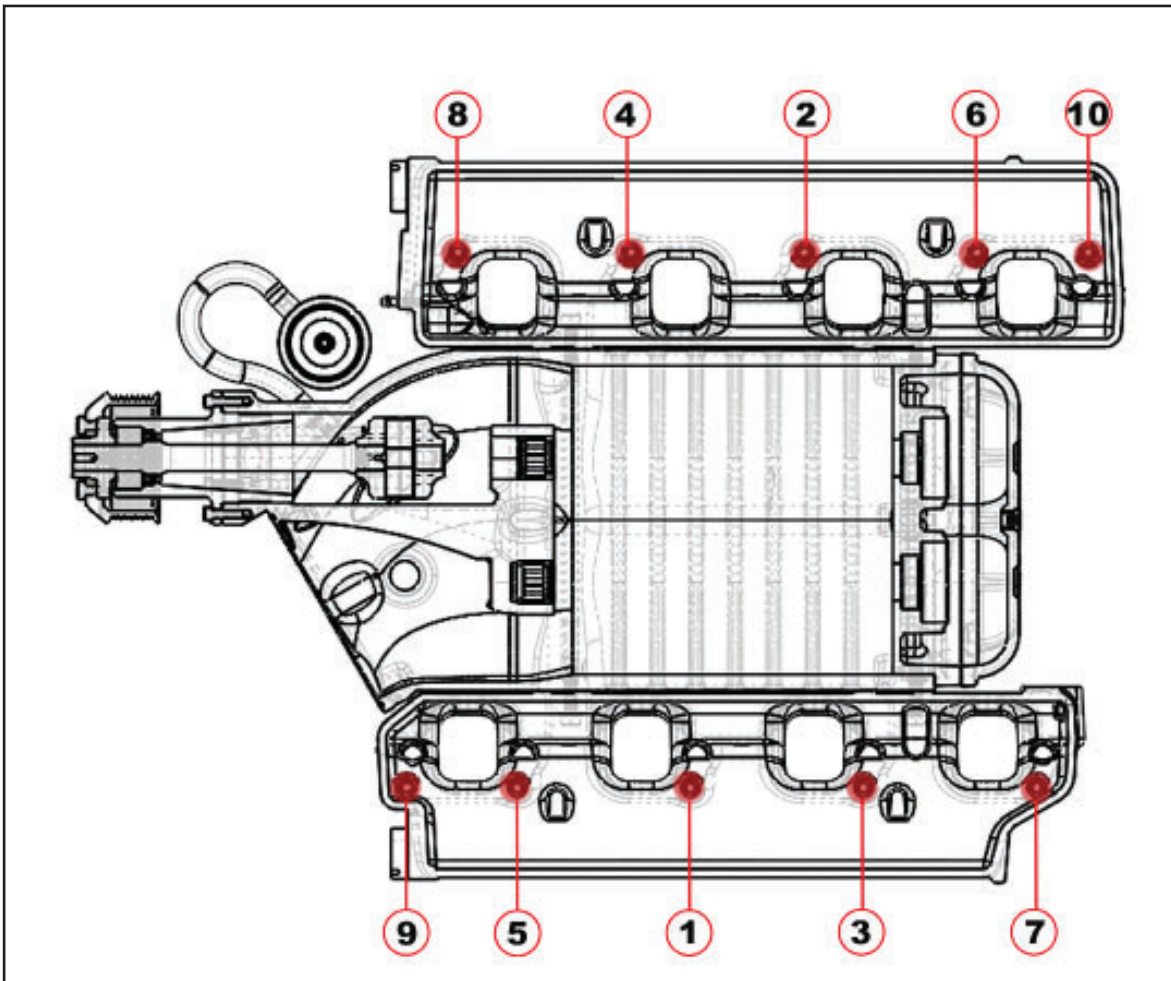

1. Supercharger to Cylinder Heads: 106in-lbs

Torque Specifications

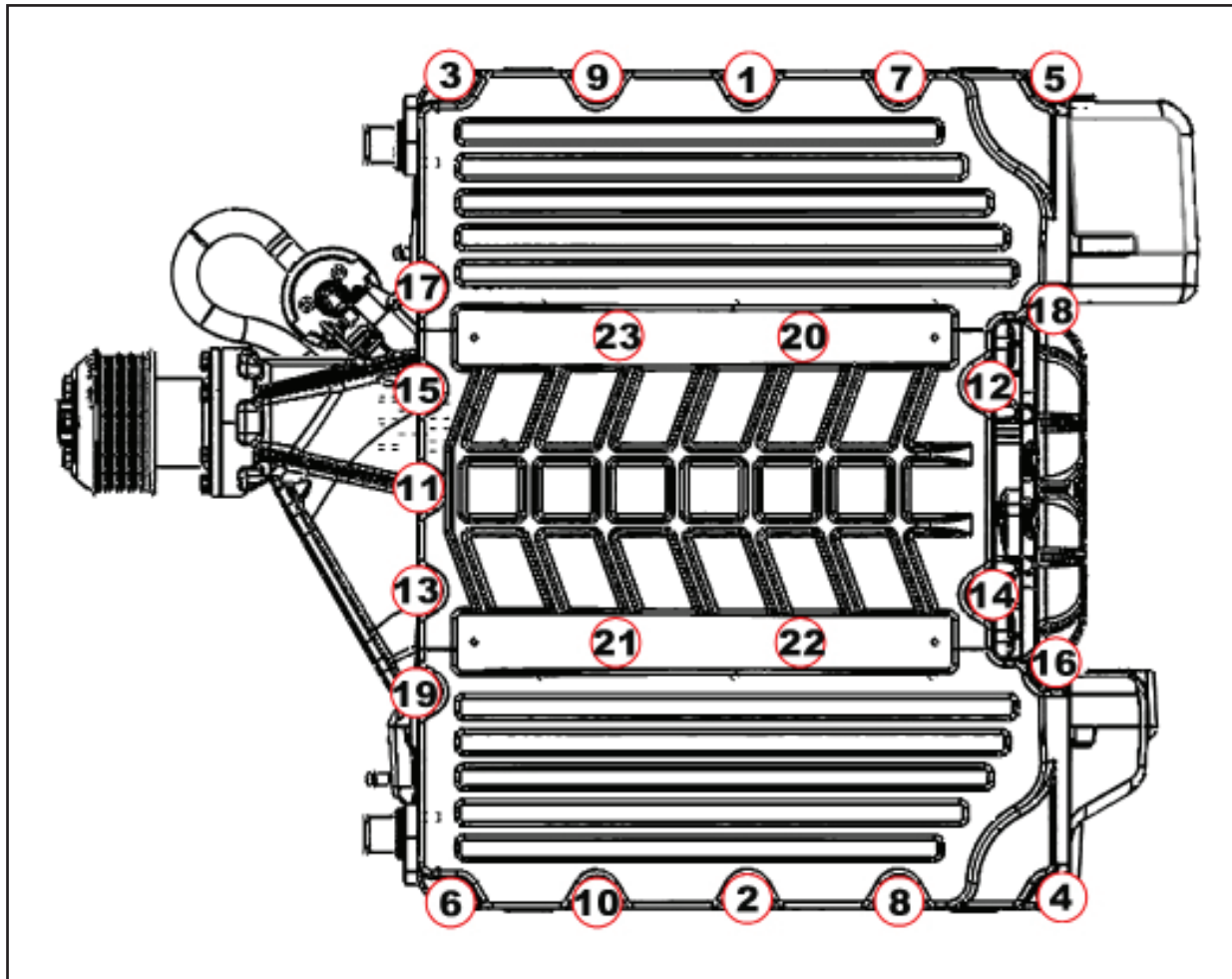

1. Lid to Supercharger Housing: 106in-lbs

NOTES



If you have questions about your vehicle's performance, please check with your installation facility.

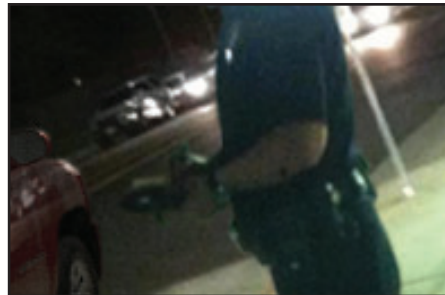

Please enjoy your Magnuson Super Charged performance responsibly.

MAGNUSON
SUPERCHARGERS