



SUPERCHARGER INSTALLATION MANUAL

2018 AND UP FORD MUSTANG GT 5.0L COYOTE



WHIPPLE SUPERCHARGERS
3292 NORTH WEBER AVE
FRESNO, CA 93722
TEL 559.442.1261
FAX 559.442.4153

WWW.WHIPPLESUPERCHARGERS.COM

**A COLOR PDF OF THIS MANUAL IS AVAILABLE, EMAIL
TECH@WHIPPLESUPERCHARGERS.COM FOR A COPY**

PREMIUM FUEL ONLY (91 OCTANE OR BETTER ALWAYS) RON+MON/2

CALIFORNIA AIR RESOURCE BOARD EXECUTIVE ORDER# D231-52

**COMPETITION BASED PRODUCT MAY BE USED SOLELY ON VEHICLES USED IN SANCTIONED COMPETITION WHICH
MAY NEVER BE USED UPON A PUBLIC ROAD OR HIGHWAY**

INTRODUCTION

Before beginning installation, please read this manual and important notes:

- Please read the installation manual and verify that all items are present. If you are missing hardware or have any questions, please contact your dealer or Whipple Superchargers before you start the installation.
- Premium fuel (US 91 octane) is required to prevent spark-knock/detonation under certain operating conditions. Other countries must meet US 91 octane standards, RON+MON/2. If fuel of less than 91-octane is present in the vehicle fuel tank, the tank must be completely drained and refilled with 91 or higher octane to 1/8th of a tank.
- Operating your engine without the Whipple Calibration can result in engine damage or failure and will void your warranty.
- Supply your VIN number (along with gear ratio, transmission type, throttle body type and any changes to vehicle) to Whipple ahead of time so your unique PCM calibration can be built prior to the SC installation to minimize any down time. **NOTE:** Whipple does not support long tube headers or cat removal. While the vehicle may run correctly, it will no longer be emissions legal and therefore not supported.
- **NEVER MANUALLY MOVE THE BYPASS ACTUATOR, YOU CAN RUPTURE THE INTERNAL DIAPHRAM.**
- COMPETITION BASED PRODUCT MAY BE USED SOLELY ON VEHICLES USED IN SANCTIONED COMPETITION WHICH MAY NEVER BE USED UPON A PUBLIC ROAD OR HIGHWAY, UNLESS PERMITTED BY SPECIFIC REGULATORY EXEMPTION (VISIT THE "EMISSIONS" PAGE AT [HTTP://WWW.SEMASAN.COM/EMISSIONS](http://www.semasan.com/emissions) FOR STATE BY STATE DETAILS.
- COMPETITION BASED PRODUCT IS LEGAL IN CALIFORNIA ONLY FOR RACING VEHICLES WHICH MAY NEVER BE USED, OR REGISTERED OR LICENSED FOR USE, UPON A HIGHWAY.
- IT IS THE RESPONSIBILITY OF THE INSTALLER AND/OR USER OF THIS PRODUCT TO ENSURE THAT IT IS USED IN COMPLIANCE WITH ALL APPLICABLE LAWS AND REGULATIONS.

RECOMMENDED TOOLS AND SUPPLIES

The following items are not included in this supercharger kit and it is strongly recommended that they're used for ease of installation or maximum performance:

Engine Oil

Whipple highly recommends running Ford Motorcraft 5W-50 full synthetic motor oil (PN #XL-5W50-QGT) vs the stock 5W-20. You will need 10 quarts for an oil change along with a Motorcraft oil filter #FL-500.

Tools

¼" and 3/8" torque wrenches. Safety glasses, metric wrench set, electric or air drill, 1 ½" hole-saw, hack saw, ¼", 3/8", ½" assorted metric socket set, 5mm ball head allen, 3/8" assorted metric allen socket set, 3/8" assorted torx socket set, 8mm hex allen wrench, ½" breaker bar, flat head and Philips screw drivers and drain pan (for coolant). Heat gun or small torch for heat shrinking. Electric tape. Trim pad tool (for pushpin removal).

Tie Straps

These will be useful for securing the wiring harness away from the installation area as directed in the instruction manual. They are inexpensive and will be very handy during installation. You will need an assortment of 4", 8" and 12".

Sealants, Chemicals and Lubricants

Anti-seize for bolt and spark plug threads (use only when stated, otherwise the torque value must be reduced). Assembly lubricant (white lithium grease or petroleum jelly). Cleaner/degreaser such as carb cleaner. Blue Loctite #243 or equivalent.

You'll be required to fill your intercooler system with approx. 2.5 gallons of distilled water and Ford Factory specification engine coolant. This is not supplied in the system, you can find the coolant at any local auto parts store. NEVER USE TAP WATER, as it can corrode and create poor performance.

Clean Shop Towels

Use these to keep the installation area clean.

PRE-INSTALLATION CHECKLIST

Before installing your Whipple Supercharger Kit, complete the following checklist.

1. Vehicle Break-in: Brand new vehicles with sub 1000 miles should maintain OEM break-in procedures for the engine, clutch or transmission. Applying extra stress to the power-train before proper break-in is not recommended and could lead to damage.
2. Verify Condition of Vehicle: Before the supercharger kit is installed, ensure the engine runs smoothly and that the factory malfunction indicator light (MIL) is off. Only install the supercharger kit if the engine runs smoothly *and* the MIL is off.
3. **!! CAUTION !!** This product is intended for use only on STOCK, UNMODIFIED, WELL-MAINTAINED engines. Installation on a worn-out or modified engine is not recommended without factory computer and fuel system modifications. Custom engine configurations could require custom tuning and other supporting modifications. Whipple does not offer custom calibrations.
4. Verify Fuel System: Supercharger systems should only be installed on vehicles that have new or clean fuel filters.
5. Assess Cleanliness of Installation Area: Make sure your work area and the under-hood area are free from debris. This supercharger is a high-quality, close-tolerance compressor and must not be subjected to contamination by dirt or any type of foreign material. If necessary, vacuum around engine to remove any foreign material.
6. **!! CAUTION !!** DO NOT remove the protective seal on the supercharger prior to installation. Foreign material entering the supercharger will automatically void all warranties.
7. Identify Supercharger Kit Components: Before beginning installation, identify all the components of your Whipple Supercharger Kit and ensure all items are present and undamaged.
8. **!! CAUTION !!** Do not attempt to start the engine before adding the supplied Supercharger Oil to the supercharger!

SAFETY PRECAUTIONS



CAREFULLY READ THE IMPORTANT SAFETY PRECAUTIONS AND WARNINGS BEFORE PROCEEDING WITH THE INSTALLATION!

Appropriate disassembly, assembly methods and procedures are essential to ensure the personal safety of the individual performing the kit installation. Improper installation due to the failure to correctly follow these instructions could cause personally injury or death. Read each step of the installation manual carefully before starting the installation.

- Always wear safety glasses for eye protection.
- Place the ignition switch in the off position.
- Always apply the parking brake when working on vehicle.
- Block the front and rear tire surfaces to prevent unexpected vehicle movement.
- Operate the engine only in well-ventilated areas to avoid exposure to carbon monoxide.
- Do not smoke or use flammable items near or around fuel system.
- Use chemicals and cleaners only in well-ventilated areas.
- Batteries can produce explosive hydrogen gas which can cause personal injury. Do not allow flames, sparks or flammable sources to come near the battery.
- Keep hands and any other objects away from the radiator fan blades.
- Keep yourself and your clothing away from moving parts when the engine is running.
- Do not wear loose clothing or jewelry that can be caught in rotating or moving parts.

GLOSSARY OF TERMS

ABBREVIATION	DESCRIPTION
ACT	Air Charger Temperature
DTC	Diagnostic Trouble Code
ECT	Engine Coolant Temperature
EGR	Exhaust Gas Recirculation
ETC	Electronic Throttle Control
EECPV	Electronic Evaporative emissions Canister Purge Valve
FHSCS	Flat Head Socket Cap Screw
IAT	Inlet Air Temperature
IC	Intercooler
ID	Internal Diameter
LB-IN	Pound-force inch
LB-FT	Pound-force foot
LTR	Low temp radiator
MAF	Mass Air Flow
MAP	Manifold Absolute Pressure
MY	Model Year
OBD	On Board Diagnostics
OD	Outside Diameter
PCV	Positive Crankcase Ventilation
PSI	Pound per Square Inch
SC	Supercharger
SHCS	Socket Head Cap Screw
TPS	Throttle Pressure Sensor
TRQ	Torque



****NOTICE:** Installation of Whipple Supercharger products signifies that you have read this document and have agreed to the terms stated within.

It's the purchaser's responsibility to follow all installation instruction guidelines and safety procedures supplied with the product as it's received by the purchaser to determine the compatibility of the product with the vehicle or the device the purchaser intends to install the product on.

Whipple Superchargers assumes no responsibility for damages occurring from accident, misuse, abuse, improper installation, improper operation, lack of reasonable care or all previously stated reasons resulting from incompatibility with other manufacturer's products.

There are no warranties expressed or implied for engine failure or damage to the vehicle in any way, loss of use or inconvenience or labor reimbursement. This includes merchantability and fitness.

The information contained in this publication was accurate and in effect at the time the publication was approved for printing and is subject to change without notice or liability. Whipple Superchargers reserves the right to revise the information presented herein or to discontinue the production of parts described at any time.

INTERCOOLER SYSTEM

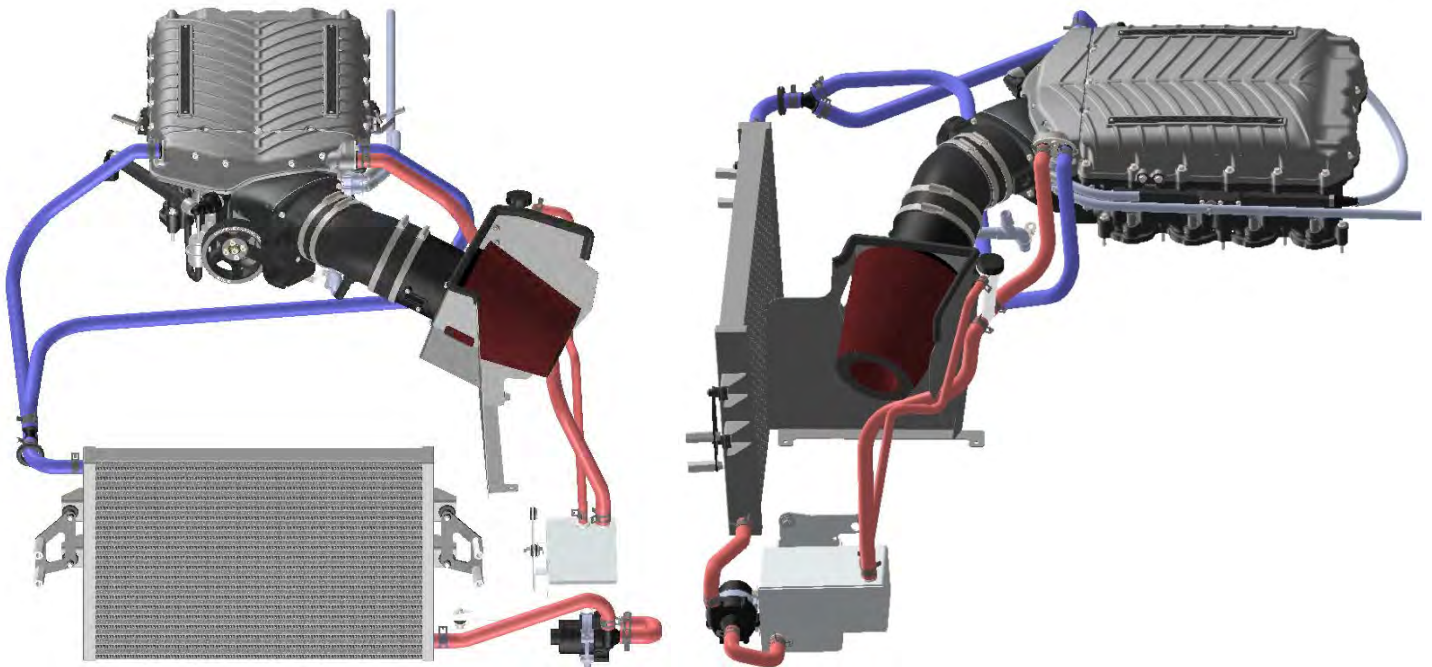
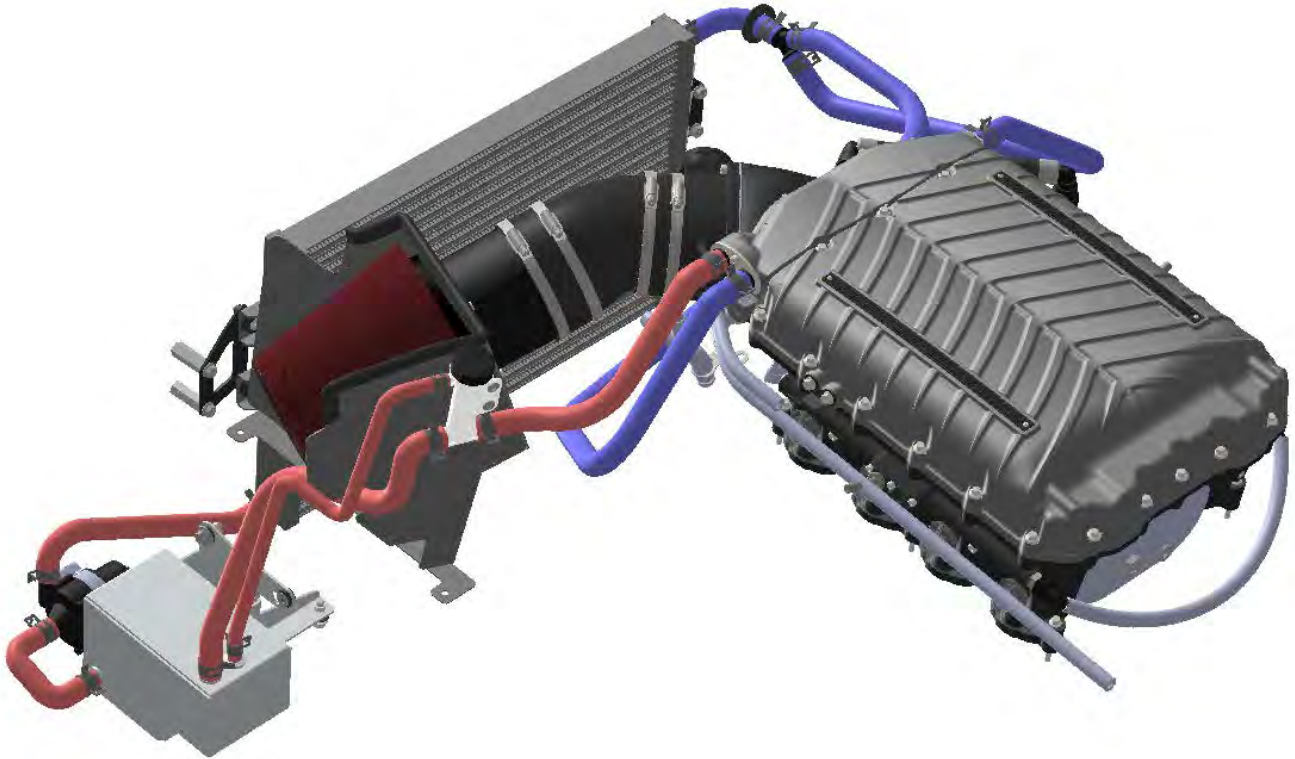

SUPERCHARGER INSTALLATION INSTRUCTIONS

It is strongly recommended that you read through this guide **BEFORE** you begin installing the Whipple Supercharger.

1. (**Complete kits/Tomahawk tool**). If you chose the Whipple Tomahawk option, read the Tomahawk instructions supplied to extract the information required, email this info to tuning@whipplesuperchargers.com a minimum of 48 hours before installation so your installation is not delayed. The tool **IS NOT PRELOADED**.
2. Using an air hose, blow off any loose dirt or debris from engine compartment. If really dirty, then steam clean the engine compartment before proceeding to the next step.
3. Release the fuel system pressure (NOTE: The following procedure is taken directly from the Ford Service Manual).

WARNING : Fuel in the system remains under high pressure even when the engine is not running. Before working on or disconnecting any of the fuel lines or fuel system components, the fuel system pressure must be relieved. Failure to do so can result in personal injury.

WARNING : Do not smoke or carry lighted tobacco or open flame of any type when working on or near any fuel-related components. Highly flammable mixtures are always present and can be ignited, resulting in personal injury.

- A. Locate the under-hood fuse panel and open the lid.
 - B. Remove the fuse for the fuel pump (fuse #48 or #49).
 - C. Start the engine and allow it to idle until it stalls.
 - D. After the engine stalls, crank the engine for approximately 10 seconds to make sure the fuel injector supply pressure has been released.
 - E. Turn the ignition switch to the OFF position.
4. Locate the battery on the passenger side of vehicle. Remove the plastic cover and (3) retaining nuts for battery access. With an 8mm wrench disconnect the (-) negative battery cable. Make sure the cable is far enough away from the battery that it does not accidentally touch the battery and make connection during the installation.
 5. Lift the front of the vehicle using the Ford recommended lifting points and place on to safety stands.
 6. With a cool engine drain the coolant into a clean drain pan for reuse later. Remove the radiator cap to vent the system. (Be careful not to remove the radiator cap if the engine is still hot). The drain petcock is located on the passenger, bottom side of radiator. Loosen spigot using a $\frac{3}{4}$ " wrench and drain into pan.

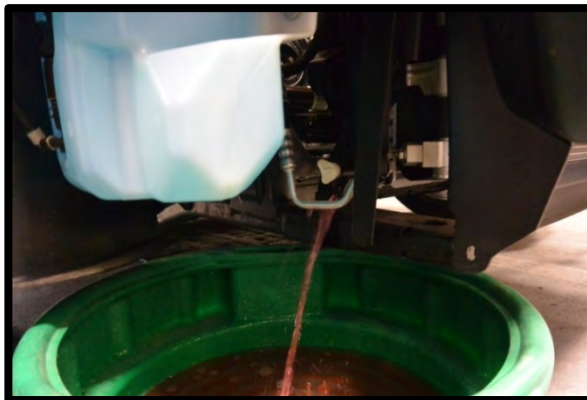

7. Remove the factory plastic radiator shroud by pulling the center of the (8) push pins and then out. Use a flat head screw driver to pry the center head up. This will all be reused.

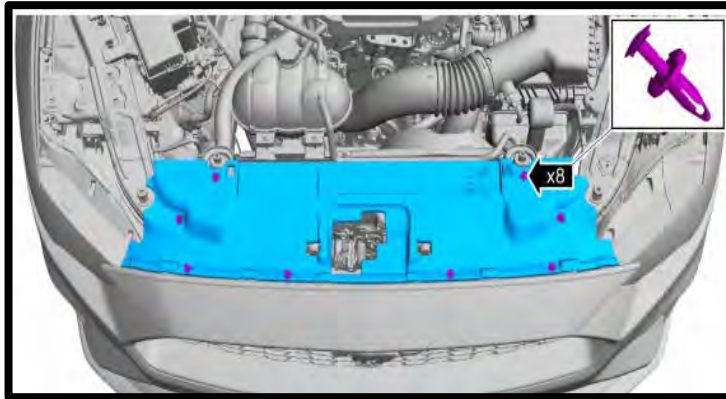

8. For best access, remove the front wheels from vehicle. Remove the push pins from the inner fender well as shown in the images (7 per side).

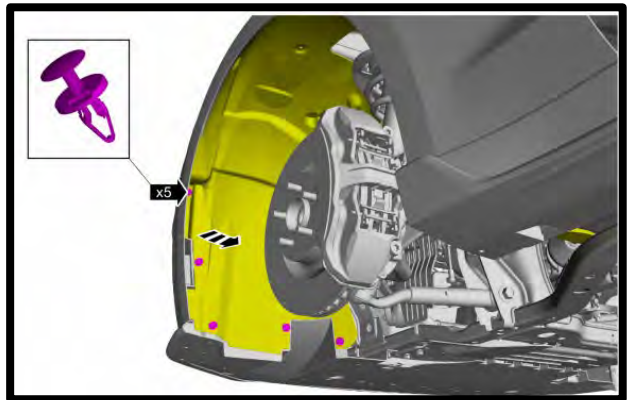
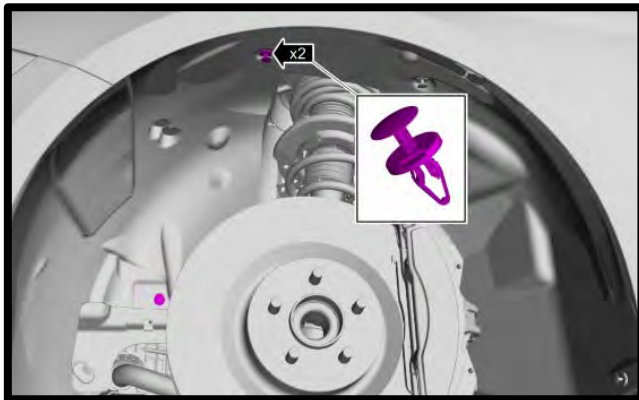

9. Remove the push pins from the (2 per side) push pins securing inner fender well to undertray.

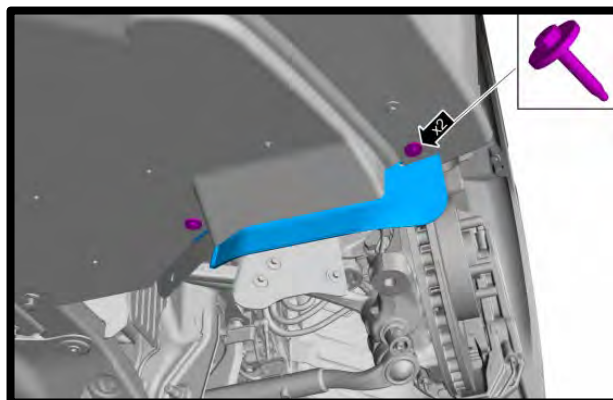

10. Remove the (19) lower close-out panel bolts (7mm socket) and the (2) push pins. Remove the lower close-out panel from vehicle.

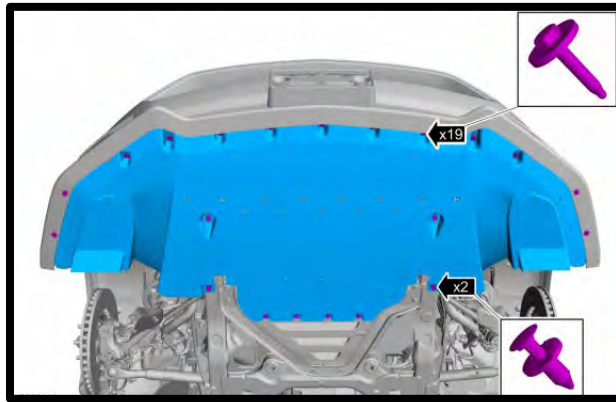

11. Disconnect the (2) fog lamps by squeezing electrical connector, releasing tension and pulling back. Remove the (2) fascia mounting brackets.

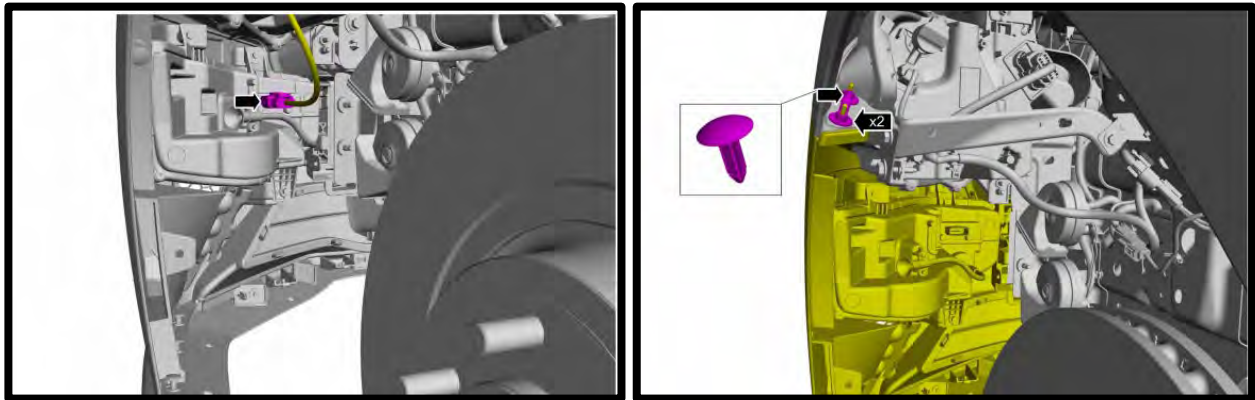

12. Carefully pull the fascia forward, disconnect the fog lamps before pulling away.

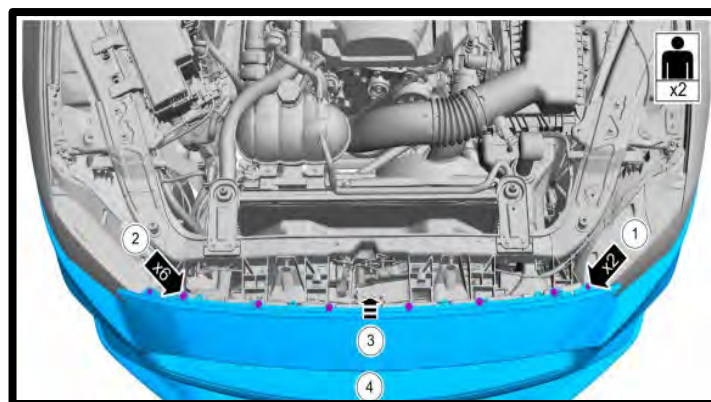

13. If equipped, disconnect the front active shutters electrical connector behind the bumper support. Remove the (6) plastic push pins securing shutter assembly to front of vehicle as shown. These will not be reused. Wrap the connector up, cover with electrical tape and secure with zip-tie to factory harness.

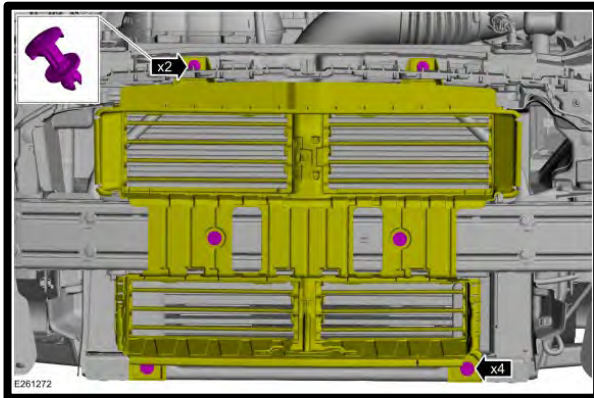
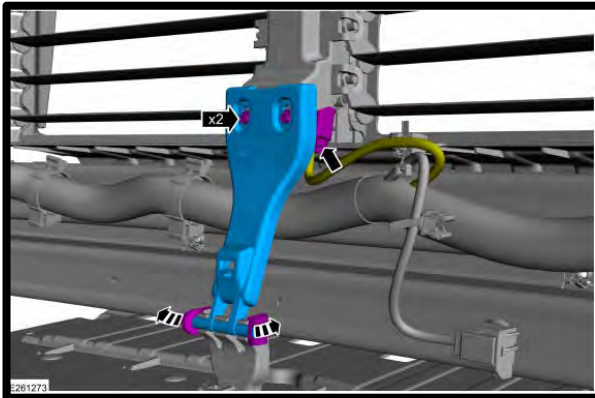

14. If equipped, remove the strut tower brace by removing the (4) factory nuts using a 15mm socket. This will not fit over the supercharger. Reinstall factory nuts (4) and torque to 25 lbs-ft.

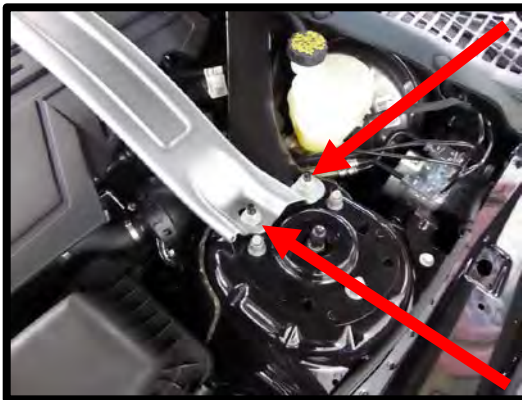

15. Using a flat head screw driver, remove the (2) plastic cups exposing the fasteners below. Using a 10mm socket, remove the (2) bolts securing cover to engine. Lift and remove cover from the engine.



16. Remove the upper cowl for K-brace access. Remove the (7) push pin retainers and (2) tabs on the cowl. Lift up the cowl trim panel and remove the (4) nuts and (5) bolts from the K-Brace using a 13mm socket, remove from vehicle for later installation.

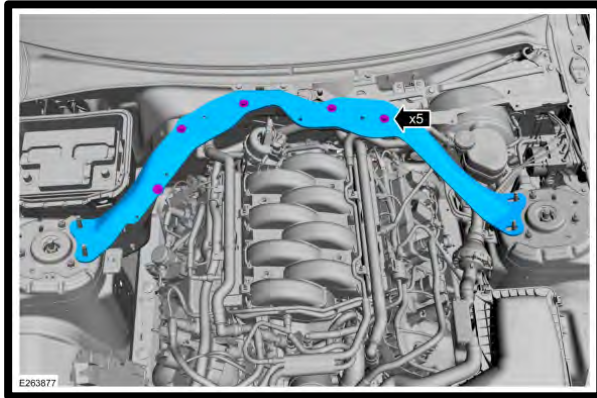
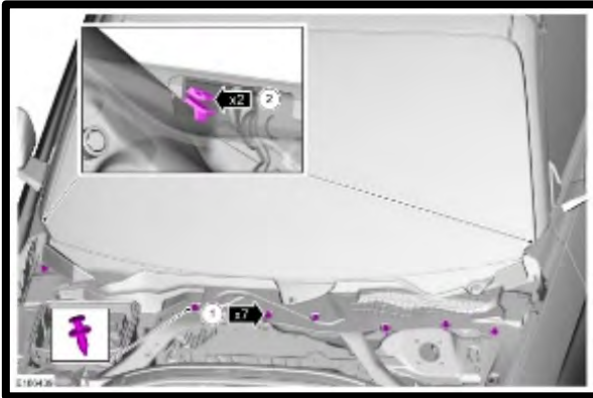

17. Rotate the oil fill tube counter clockwise and remove from engine. Remove the oil fill cap from tube. Reinstall cap into valve cover until it locks in place.



18. Remove the PCV purge line from the intake manifold and RH cam cover. One of these 90deg connectors will be reused.

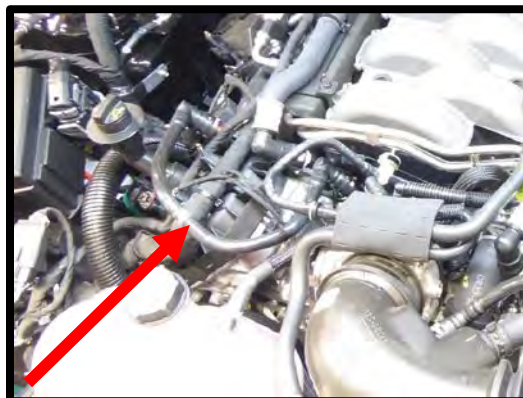

19. Pull apart the rubber shielding securing vacuum lines together.

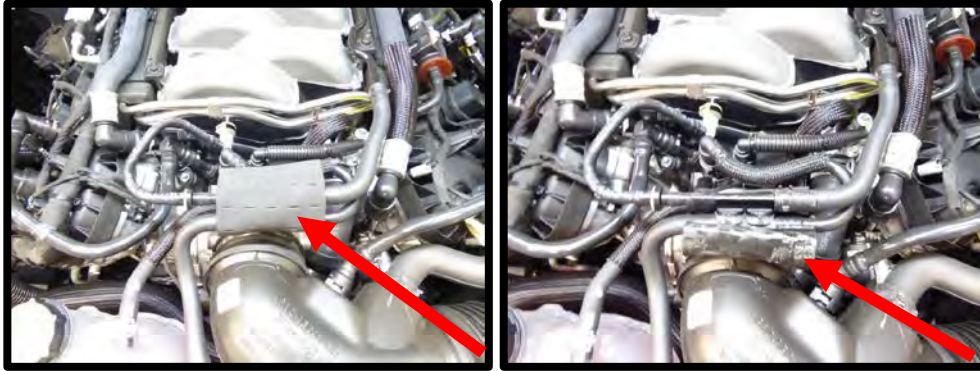

20. Disconnect and remove the brake aspirator lines from the inlet tube and intake manifold.

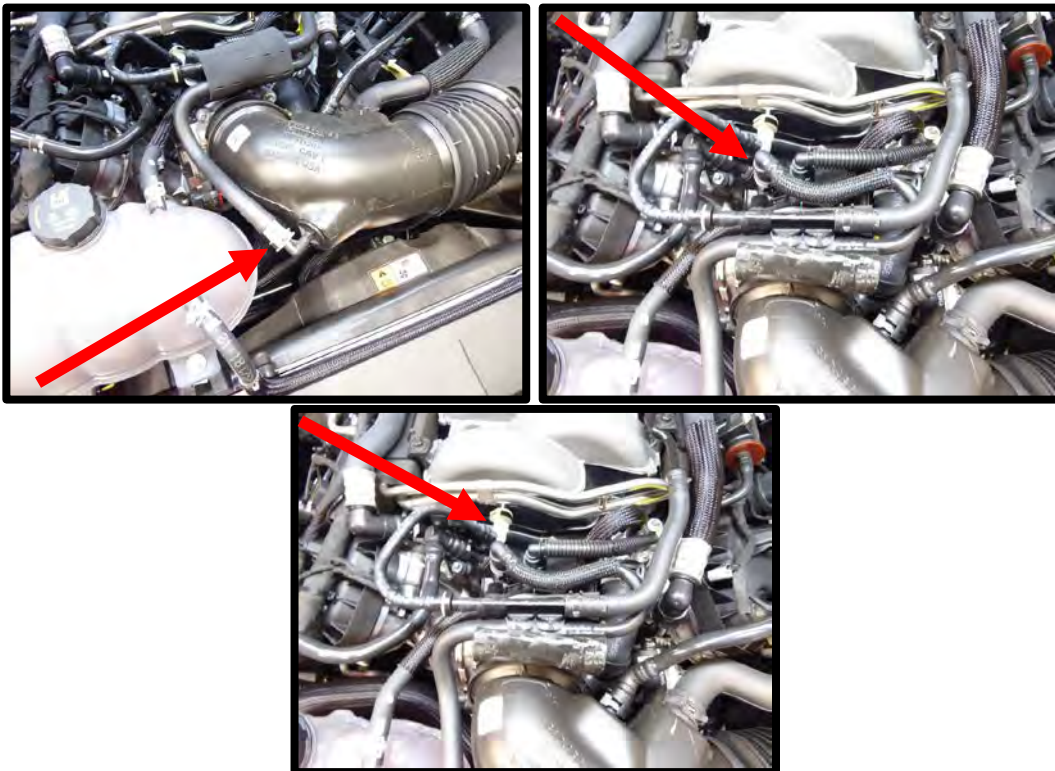

21. Using a pinch clamp tool, remove the brake booster line that connects the brake aspirator rubber line to hard line.



22. Gently pry up the push pin securing the induction resonance tube to the strut tower. Remove the mounting nut at the base of the tube at the firewall (10mm socket). Remove induction resonance tube from the cowl, this will not be reused. Install supplied sound tube delete block off to factory location.



23. Disconnect and remove the positive crankcase ventilation PCV tube from inlet tube and LH cam cover fitting.

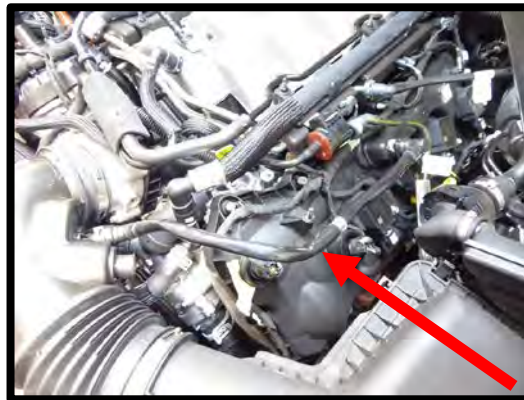

24. Disconnect the green connector from the evaporative emission canister purge valve (EECPV) tube and the electrical connector. Disconnect green connector securing EECPV line to intake manifold. Lift EECPV purge valve from intake manifold for later use.

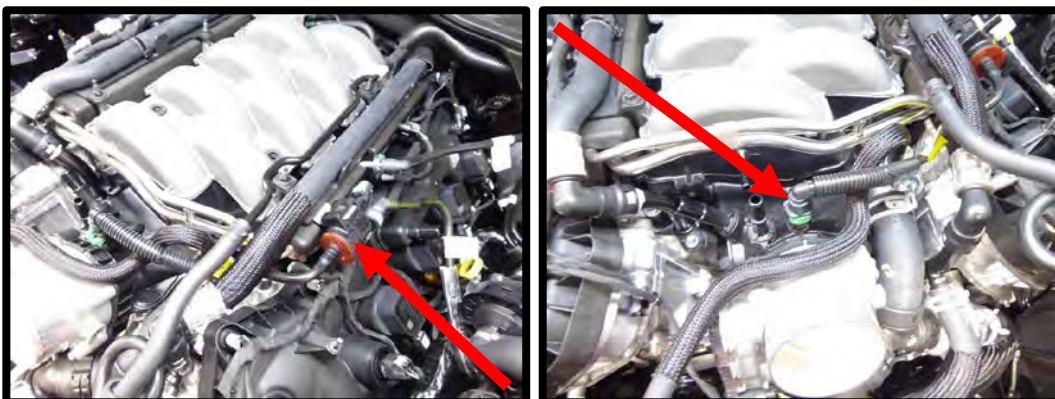

25. Disconnect the MAF connector by pulling back on the safety lock, then squeezing the unlocking tab and pulling back. Using a panel puller tool, remove the wiring harness support tab from the airbox.

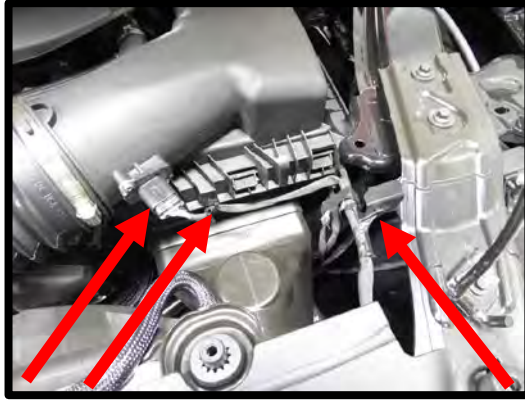

26. Loosen the factory air box lid by pushing the (2) locking tabs back. Loosen both hose clamps on the inlet tube (7mm nut driver). Remove tube, airbox lid and filter element from vehicle.

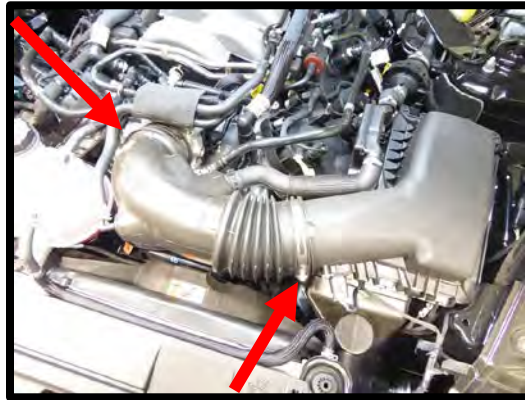

27. Remove the airbox bottom by removing the (1) bolt on the driver side inner fender (10mm socket).

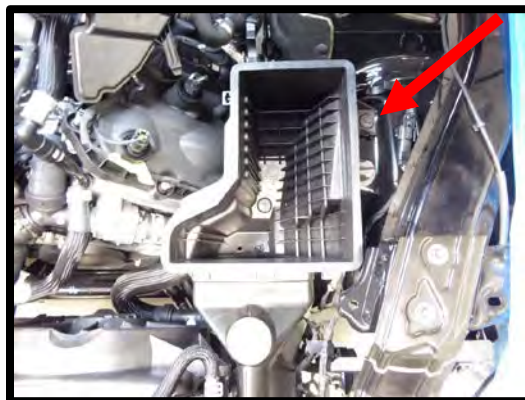

28. Pull the (2) push pins securing the engine harness to the frame on the driver side, this will be reused later to secure the airbox.

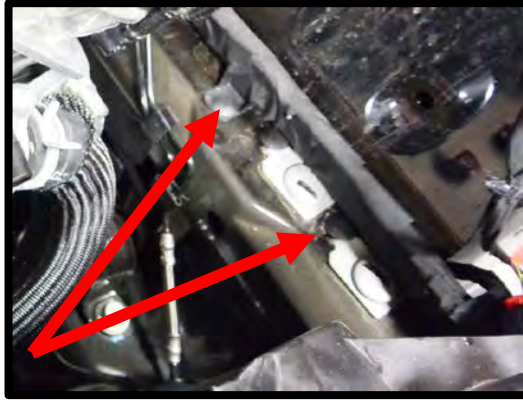

29. Carefully cut the electric tape securing the ETC wires to the throttle body. Disconnect the electronic throttle electrical connector by pushing up on the safety lock and then squeezing the connector and pulling away. Remove the harness support plastic tab from the block ground stud.

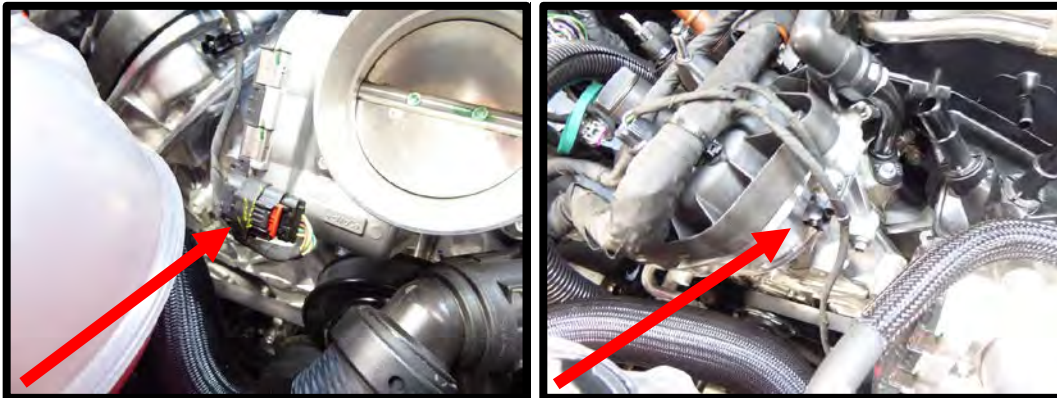

30. Remove the vent hose coming from the thermostat housing fitting by removing pinch clamp. Remove vent line from overflow tank by removing pinch clamp using a pinch clamp tool. This hose will not be reused.

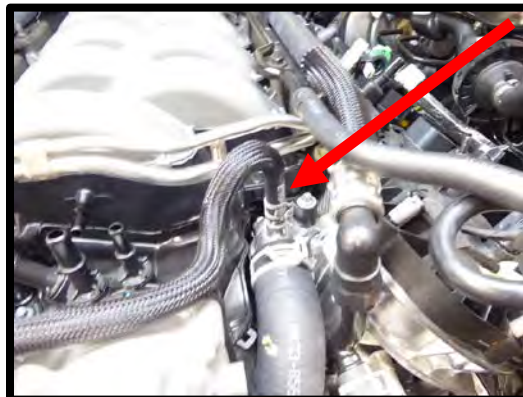

31. Remove the heater hose from both driver and passenger side of block by pulling locking tab back and pulling away. Push to the back of the engine for later use.

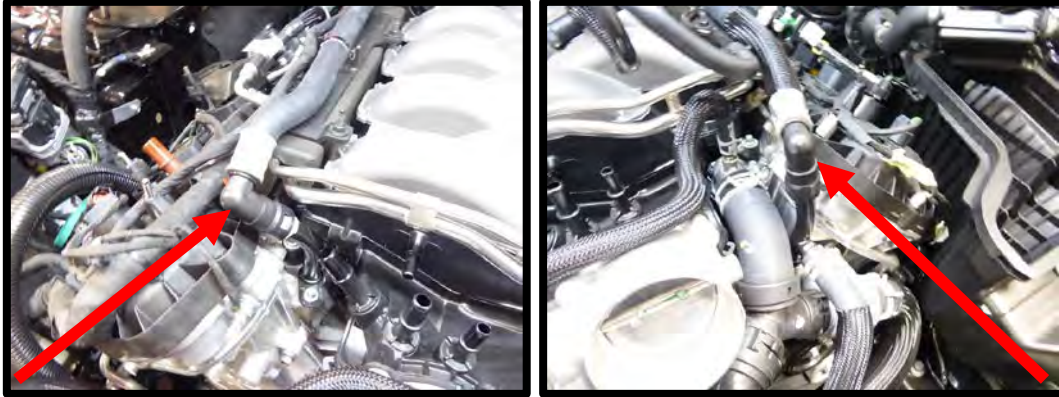

32. Disconnect the fuel psi sensor connector from driver side fuel rail.

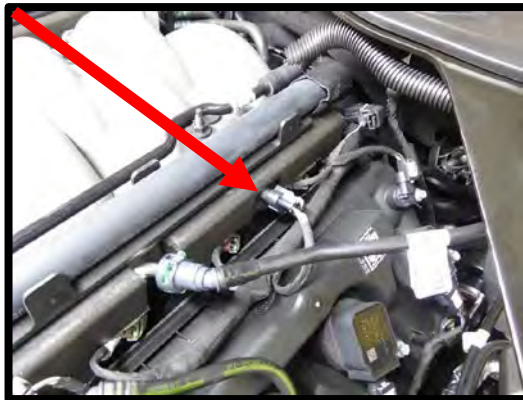

33. Carefully disconnect the factory fuel feed hose from the fuel rail. The fuel system may still have pressure, use protective eyewear and multiple rags to catch any possible fuel leak. To release, press the blue safety latch and pull the fuel fitting away from fuel rail.



34. Using a 3/8" fuel line removal tool, remove the DI pump fuel feed line from PI fuel rail.



35. Remove the (4) nuts from the top of the intake manifold that secures the (2) heater hose trays and brake aspirator line. Use a 10mm deep well socket. Once bolts are removed, remove tray, brake aspirator and foam material.

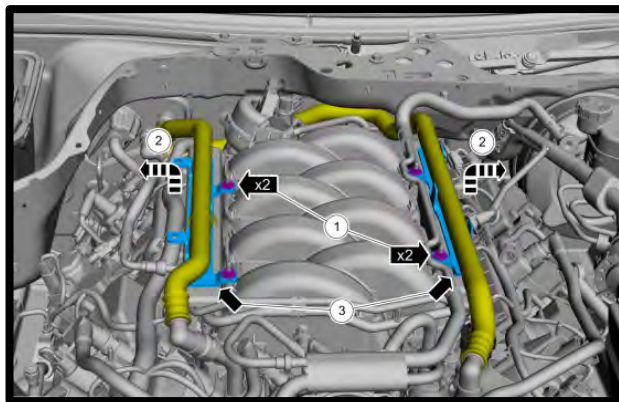

36. Loosen the 4 bolts holding the fuel rails down, these go through to the cylinder head (10mm socket). Fuel rail does not need to be removed.

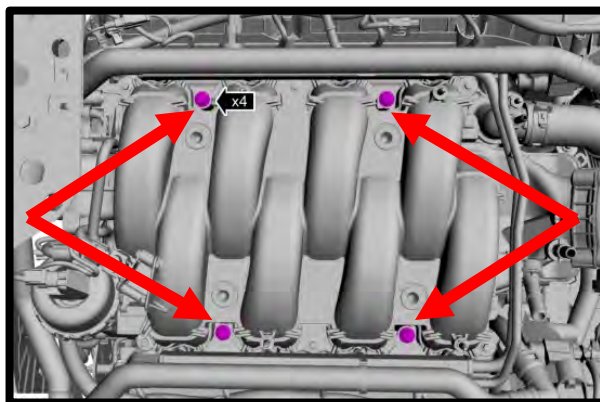

37. Disconnect all fuel injector connectors by using a flat head screw driver on one side of the clip. Pry to one side and clip will slide off.

38. Loosen the (6) manifold to cylinder head bolts using an 8mm socket and lift the intake manifold forward to access the CMCV harness connector. Use a trim tool to remove the harness from the intake. Using some colored tape, mark the LH (bank 2) CMCV 3-way connector as this will be used later. Disconnect the (3) harness connectors and release/remove the (2) push pins. Caution: Do not cut the harness.

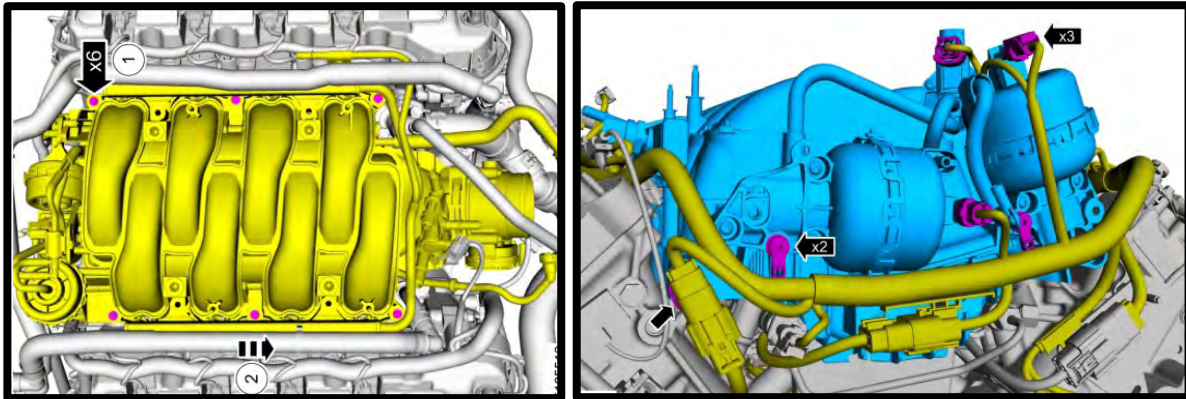

39. Clean the intake manifold to cylinder head surface using carb cleaner or acetone. Install tape over the exposed ports until manifold installation.



40. Remove the coolant to heater tube overflow hose using a pinch clamp tool. Pull away from heater tube.



41. Remove the driver side heater tube from engine by removing the (1) bolt using an 8mm socket.



42. Loosen the (3) bolts securing the water pump pulley (while belt is on) using a 10mm socket.

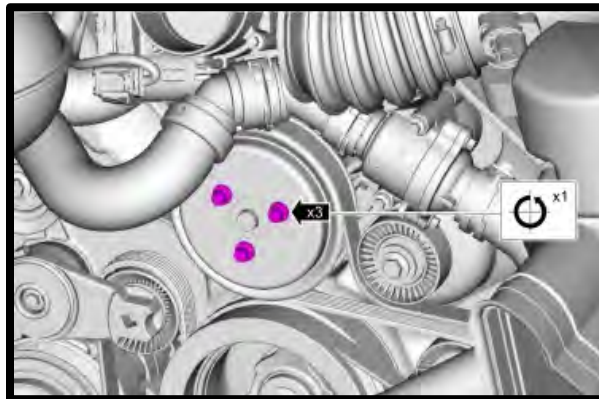

43. Remove the belt from the engine by using a 15mm socket on a ½" breaker bar and rotating the spring-loaded tensioner in a clockwise direction.

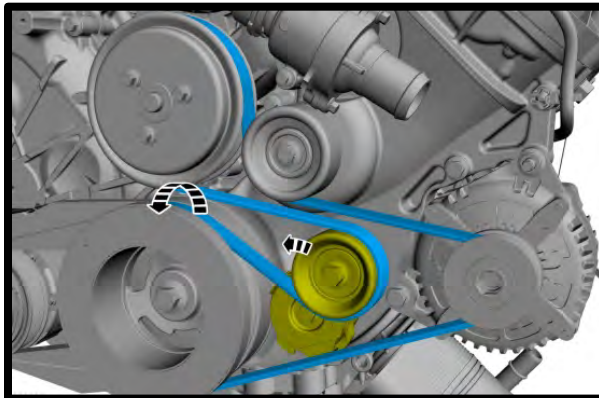

44. Remove the spring-loaded tensioner from the engine using a 13mm socket.

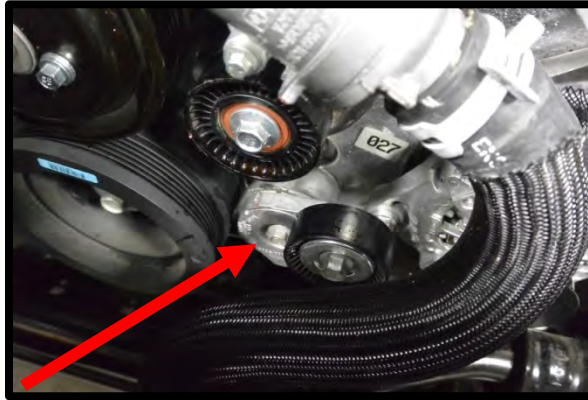

45. Remove the water pump pulley using a 10mm socket (this will be reused).

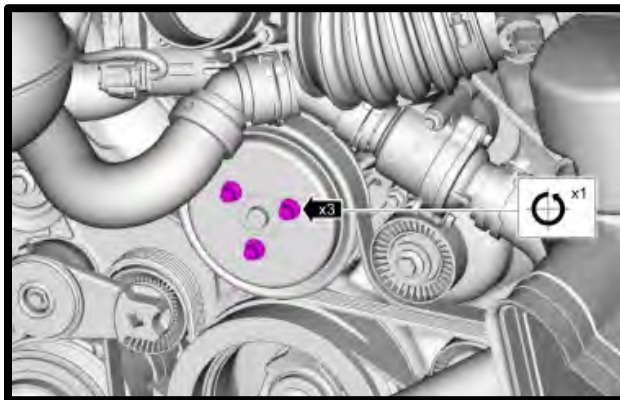

46. Using a 27mm socket, remove the fuel PSI sensor from the factory fuel rail. This will be reused at a later step.



47. **(Stock throttle installations)** Remove the throttle body from the manifold by removing the (4) bolts using a 10mm socket.

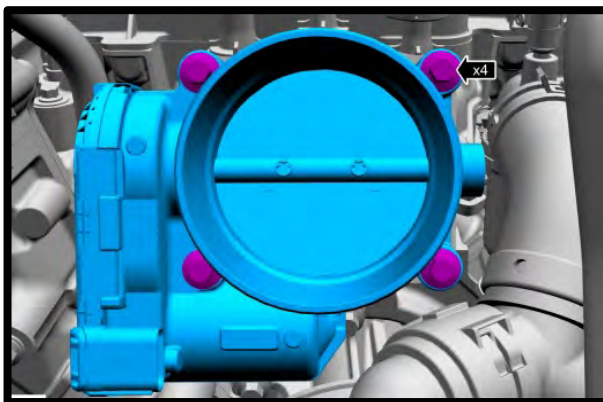

48. **(Complete kits)** Gap the supplied spark plugs to **.028"** (out of box is **.050"**). Only use a **.28"** feeler gauge, any other method will lead to inconsistent results. Install the gapped NGK LTR7IX spark plugs. Apply light amount of anti-seize to threads. Torque spark plugs to 128 lbs-in. Reinstall the coils on plugs and torque bolts to 53 lbs-in. **NOTE:** Competition based systems require you to source your own spark plugs, consult your tuner for information.

49. Install the supplied driver side heater tube to driver side of block (bracket has step in it). Install the supplied oring to the tube and apply light amount of grease to oring surface. Install tube into block and secure with the factory bolt using an 8mm socket. Torque to 89 lbs-in.



50. Install the supplied tee and 90deg hose to the driver side heater tube you just installed. Secure with the supplied pinch clamp on the 90deg hose to heater tube. **NOTE:** Short end of 90deg goes on heater tube, long end goes on tee fitting.



51. Using the supplied 3/4"ID x 24.5" hose coming from the supplied tee fitting, route between cylinder head and water neck. Cut factory hose length so the hose will go straight back towards firewall. **TIP:** Best place to cut is between cylinder 5 and 6 coils. Once cut to proper length, slide the supplied sheaving on the supplied hose and (2) pieces of rubber heat shrink (for later install). Install the supplied shrink clamp over factory heater hose. Install the factory driver side heater hose to the coupler. Use a heat gun to secure the shrink clamp and lightly shrink sheaving to hose. **TIP:** Use zip-ties to secure hose to LH cam cover.

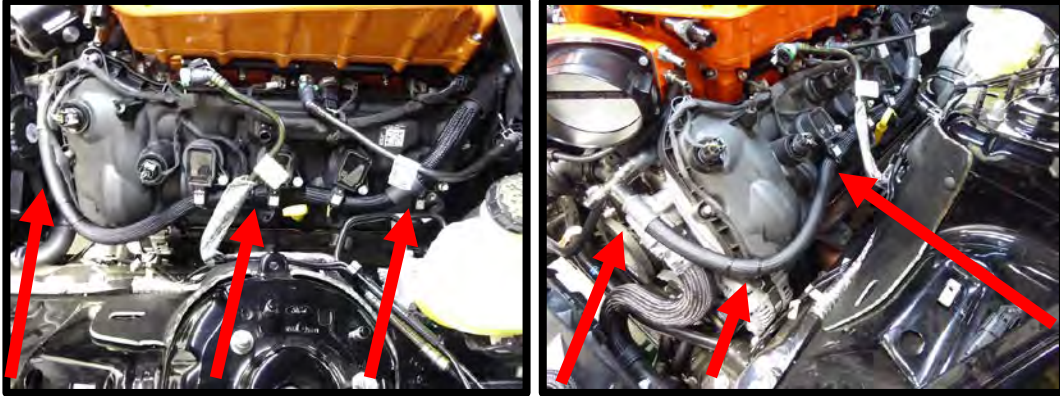

52. Install the factory coolant overflow hose to the new supplied tee fitting on the driver side. Secure using factory pinch clamp.



53. Using needle nose pliers, rotate the factory pinch clamp at the water neck towards the driver side for future clearance of the SC. **NOTE:** Image shows clamp with SC installed to illustrate max clearance.

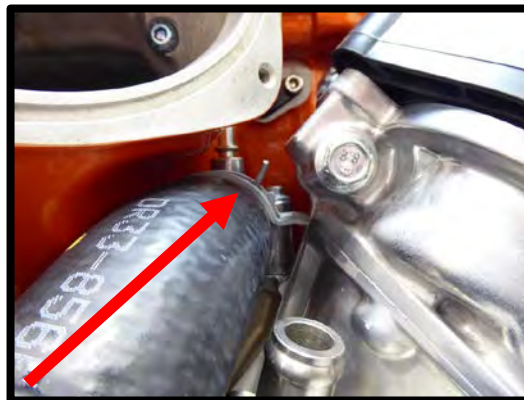

54. Install the supplied ¼" formed hose from the water neck vent line, route towards the overflow tank for later installation. Secure with stock clamp. NOTE: Shown with SC on for routing direction.

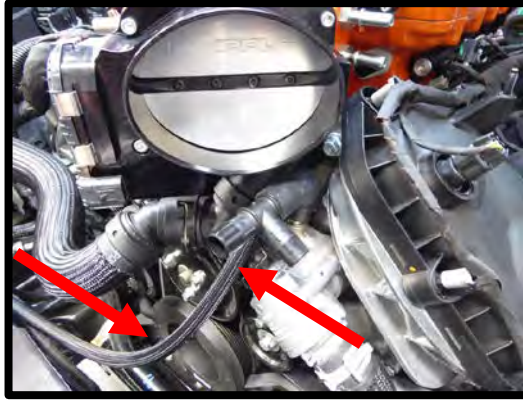

55. Remove the upper radiator hose from radiator. Use a hose cutter, remove 1" from the radiator hose end. Reinstall hose once completed and secure with factory hose clamp. TIP: This is for added clearance for the new belt system.

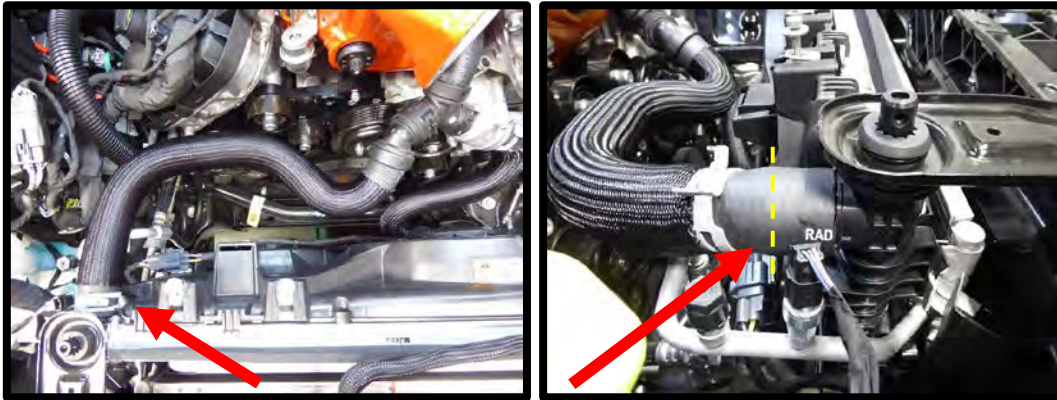

56. Remove the coolant vent hose from the radiator and pull back the plastic sheaving. Shorten this hose end by 1" for additional clearance. Reinstall hose using factory clamp.

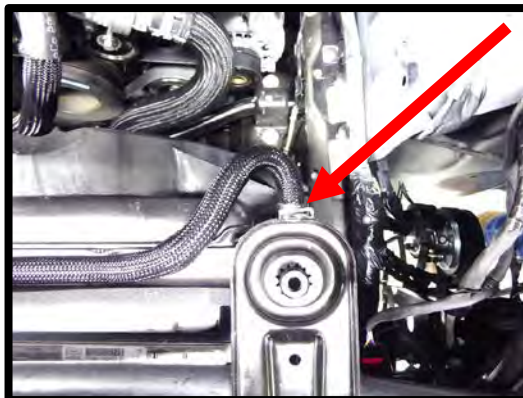

57. **(Complete kits)** Connect the supplied 3-way to 2-way air charge temperature pigtail at the rear of the passenger side cylinder head to the 3-way IMRC connector (**Yellow, Orange, Green wires**). Route to the RH side of the engine for later installation. **NOTE:** This will not work on competition or non-Whipple calibration systems. For competition-based systems, you will be required to supply your own method of monitoring post intercooler temperature.

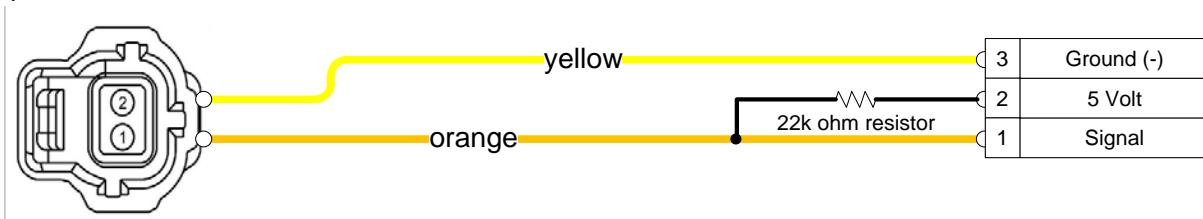

58. Locate the stock ground wire bolt, located on RH side of vehicle, next to strut tower brace using an 8mm socket. Install the intercooler relay harness ground eyelet (black wire) along with factory ground wire. Reinstall bolt using an 8mm socket.
- **Dual fan installations:** Add the secondary relay harness ground to same location.

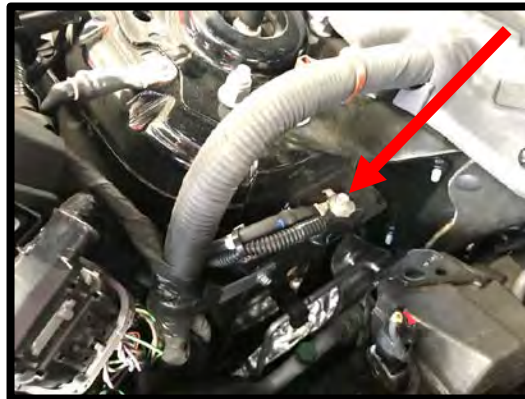

59. Open the fuse box lid. Using a 10mm socket, remove the 12V (+) power stud nut from the far post. Install the IC pump relay power eyelet (red wire) to the 12V stud. Use a 10mm socket to secure stock and IC power wire.
- **Dual fan installations:** Add the secondary relay harness power to same 12v stud.



60. Pull the red 10amp fuse from position #62 (ABS). Install the 10amp red fuse in the unused fuse slot on the fuse tap. Install the supplied fuse tap into position #62 (ABS). **Note:** 10amp red fuse should be in bottom slot, 5amp should be in top slot. Make sure wire has enough room when fuse cover closes, route around fuses for clean installation.

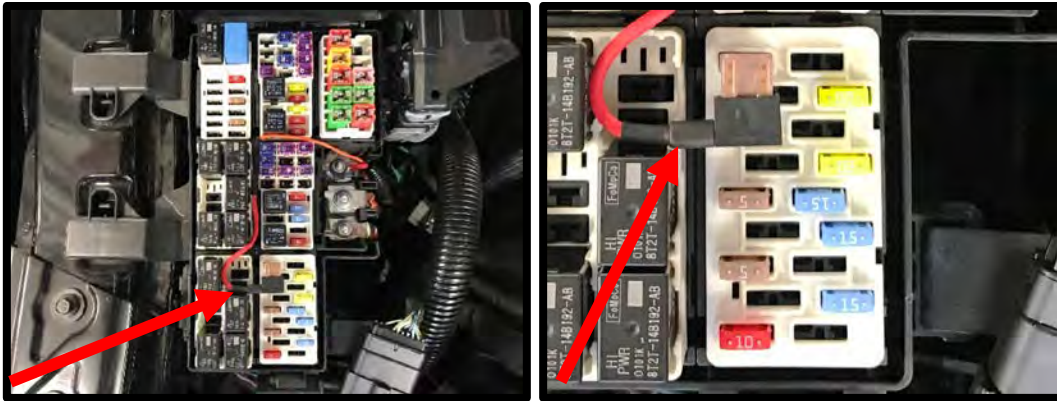

61. Mount the relay and fuse holder to the factory wire harness, secure with zip-tie. Route the 2-wire connector along the top of the condenser, to the LH side of the vehicle (near headlight). Secure harness using zip-ties.
- **Dual fan installation:** Connect the turn on, one-way connector from the IC pump relay to the dual fan relay.
 - Mount the relay and fuse to factory harness to the factory wire harness using a zip-tie.

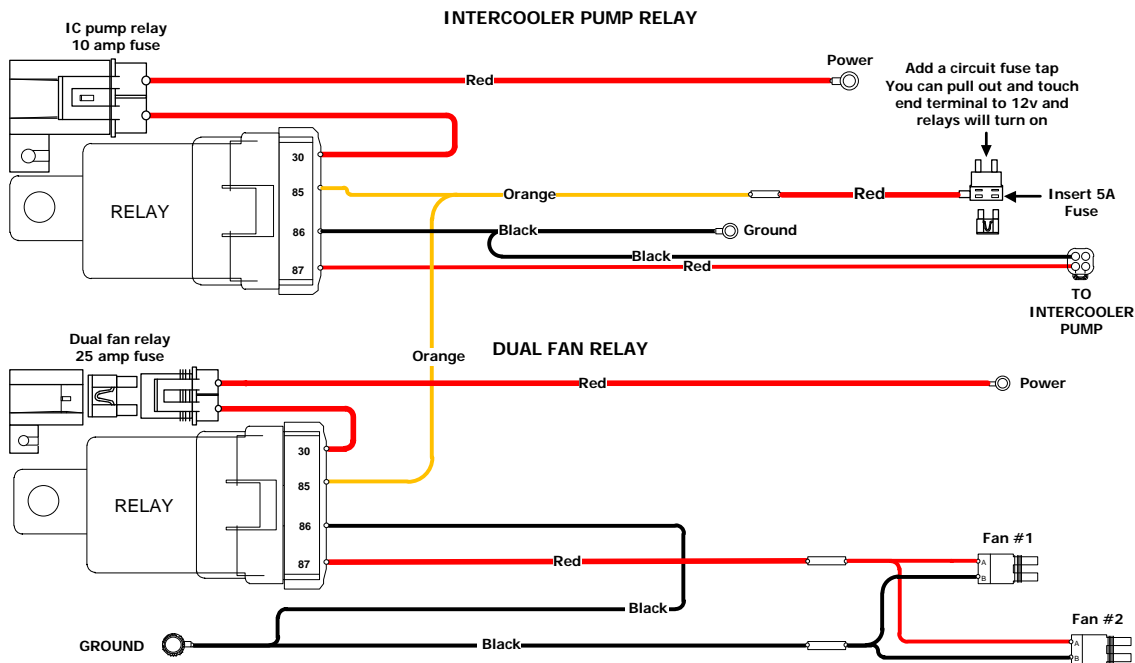

62. Using a 10mm socket, remove the (4) factory fasteners from the timing chain to head cover and (1) from water pump (for new idler plate).

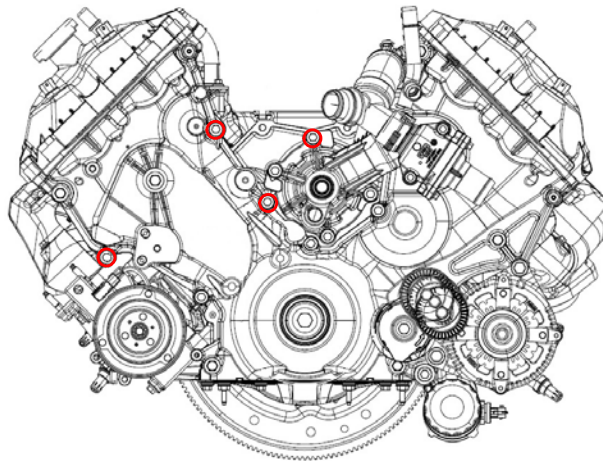

63. Install the (4) support stands to the front idler plate. These are loose fit; therefore, you must tilt backwards during installation or the stands will fall. You can use masking tape to help hold in place during installation if installation becomes difficult. **Each support stand is marked with an identifying number, as well as the idler plate for ease of placement. TIP:** Assemble together with the number facing out for future reference.



64. Use the supplied (4) 8mm x 90mm SHCS to secure the idler plate to the front of the passenger side of engine, install hand tight. Using a 6mm allen, torque to 22 lbs-ft.

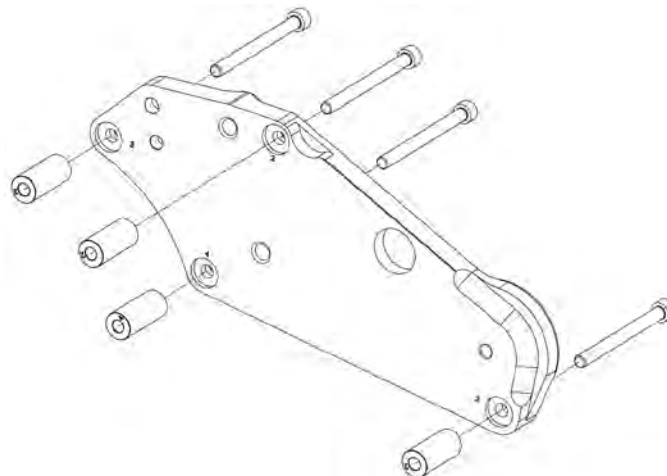

65. Preinstall the supercharger support bracket by installing on the back of the idler plate. Secure with the (1) 8mm x 70mm SHCS and (1) 8mm x 25mm SHCS, leave loose until supercharger assembly.

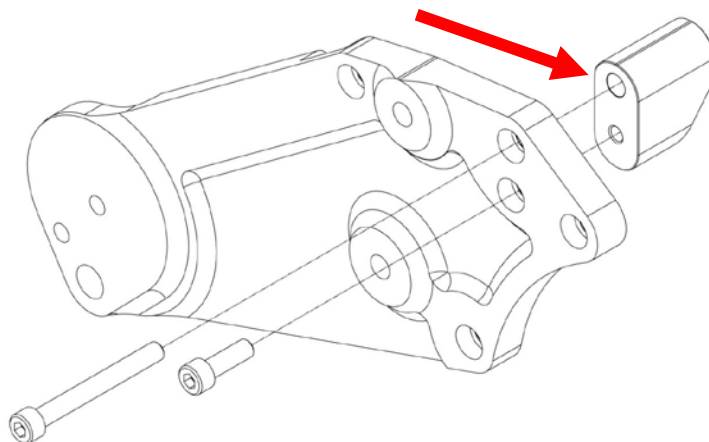

66. Install the supplied adjustable idler assembly to the factory spring loaded tensioner position. Locate the dowel pin to factory pin hole. Secure to engine using the stock bolt, torque the factory bolt to 35 ft-lb. Install the supplied idler pulley to the adjustable idler, use the supplied (.390") step spacer against the adjustable idler arm. Sandwich the smooth idler pulley (#36101) to step spacer and the supplied step washer to front side of idler. Install the supplied "tee" nut to the back side with the offset hole facing the driver side. Secure with the supplied 1/2"-13 x 2" SHCS. **TIP:** Use light amount of anti-seize on threads.

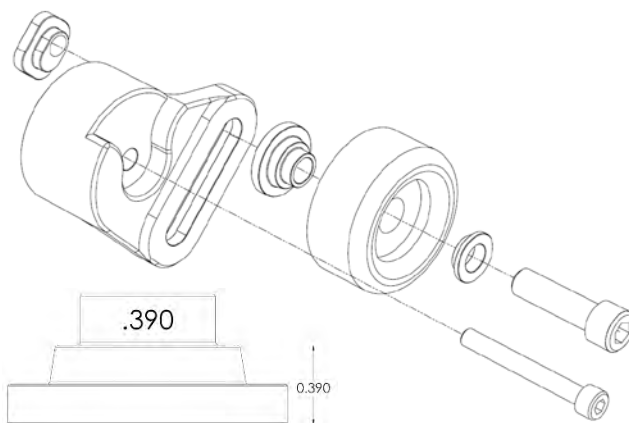

67. Remove the factory plastic smooth idler pulley from the engine. Replace with the supplied steel idler pulley. Use the factory fastener to secure. Torque to 18 lbs-ft with a 13mm socket. **NOTE:** Image shows proper direction of idler assembly.

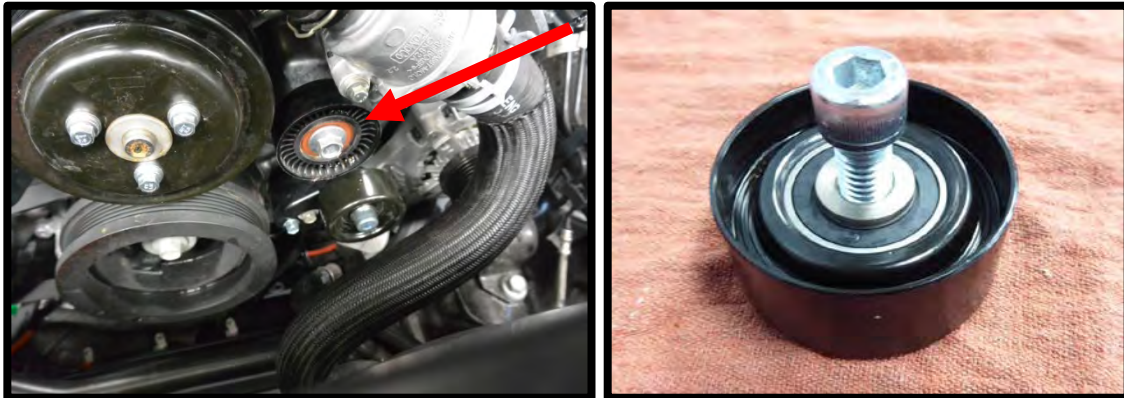

68. Assemble the spring-loaded tensioner by mounting the supplied spacer with the female register to the tensioner. Install the grooved idler pulley (#36326) to the tensioner and (.390") step spacer. Use the supplied step washer to center the bearing and the 10mm x 40mm SHCS (10-Rib uses 10mm x 60mm SHCS) bolt to secure idler to tensioner. Use light amount of anti-seize on threads. Torque to 18 lbs-ft.

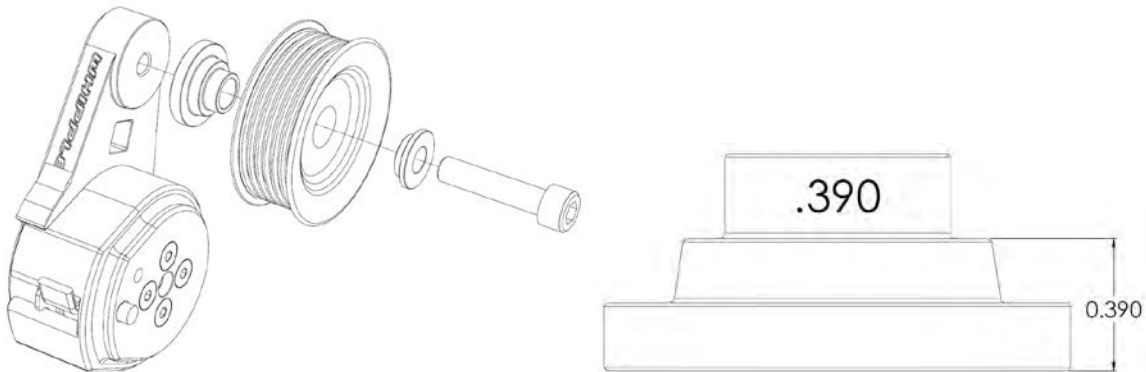

69. Carefully bend the factory AC line down and towards passenger side. Install spring loaded tensioner to plate to check clearance. You should have a minimum of 3/8" of clearance from the tensioner to the AC line.

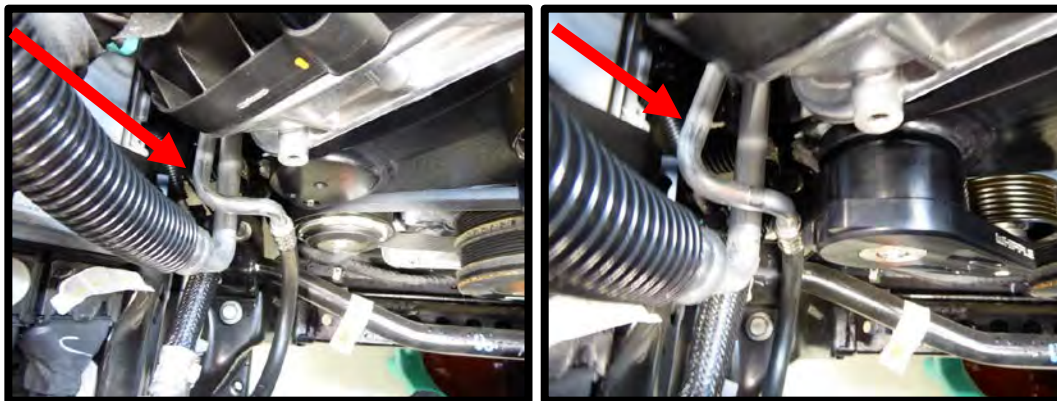

70. Install the spring-loaded tensioner to idler plate, locating the tang into position. Secure with the supplied (1) 10mm x 60mm SHCS. Use light amount of anti-seize on threads. Torque to 25 lbs-ft.

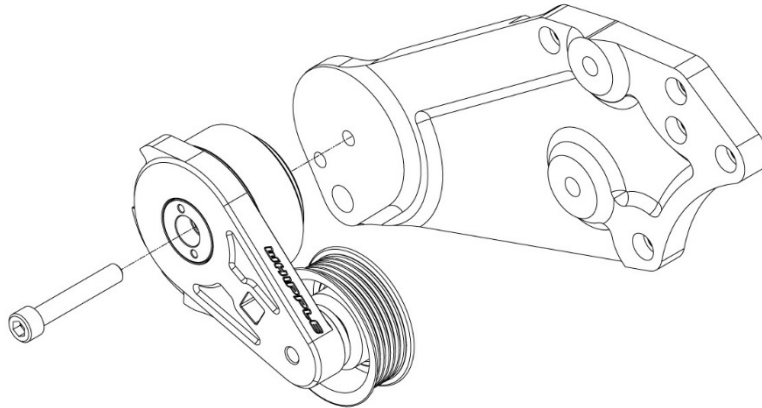

71. Install the supplied (2) smooth aluminum idler pulleys to the idler plate using the (2) (.317") step spacers. Sandwich the idler pulley to the (2) (.317") step spacer using the supplied (2) step washer, (2) 1/2"-13 x 2" SHCS. Torque to 30 lbs-ft. using a 3/8" allen socket. Use light amount of anti-seize on threads.

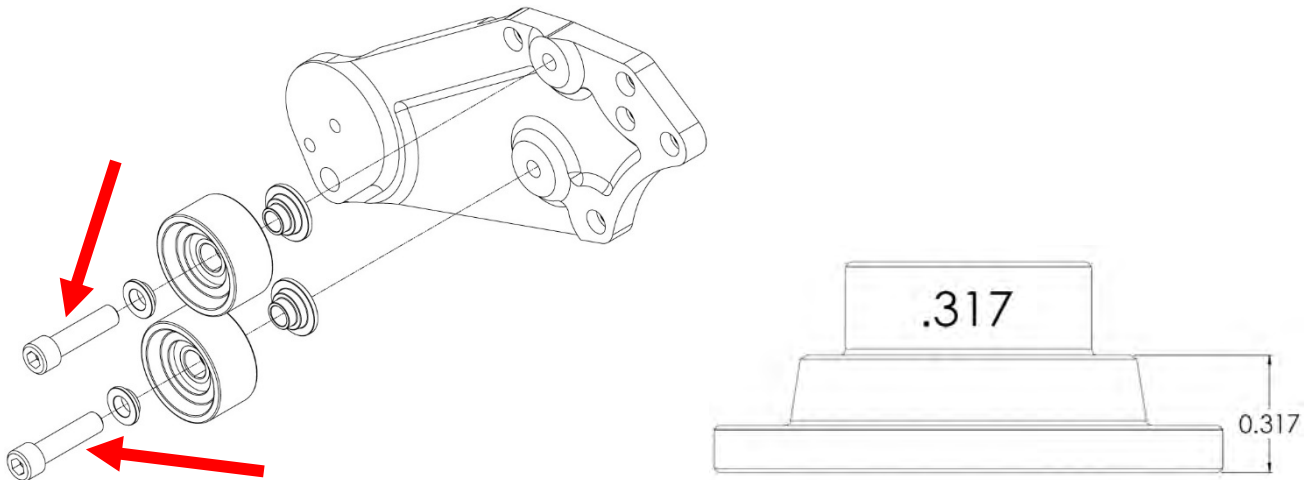

72. Install the (1) #2-109V75 oring to the MAP sensor block off and apply light amount of grease to oring. Install the MAP sensor port with the supplied block off plate, secure using the supplied (1) 6mm x 16mm SHCS. Torque to 70 lbs-in.

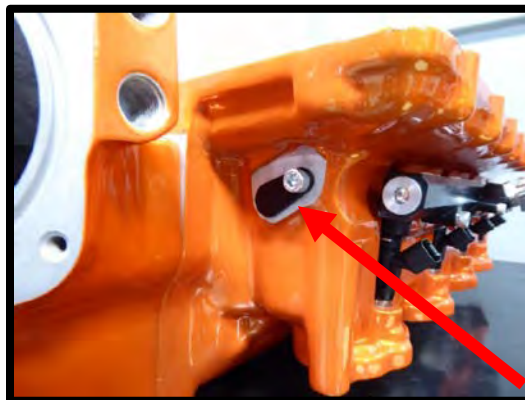

73. Using a 13mm socket, remove the (20) 6mm flanged hex bolts securing the supercharger lid to housing. Remove the lid from the housing. Set the lid and intercooler assembly on a padded surface so no damage can occur to intercooler cores.
74. Install the supplied (8) manifold orings to the Whipple intake manifold to cylinder head surface, apply light amount of grease to ease installation.



75. (**Complete Kits**) Install the supplied air temp sensor to the 3/8" NPT port on the back of the intake manifold. Be careful, as the plastic sensor can break if over torqued. Use light amount of oil on threads. (**Competition Kits**) Per your tuner, if adding an air temp sensor for post intercooler, install in 3/8" NPT port on back of SC housing, if not, plug the hole using the 3/8" plug.

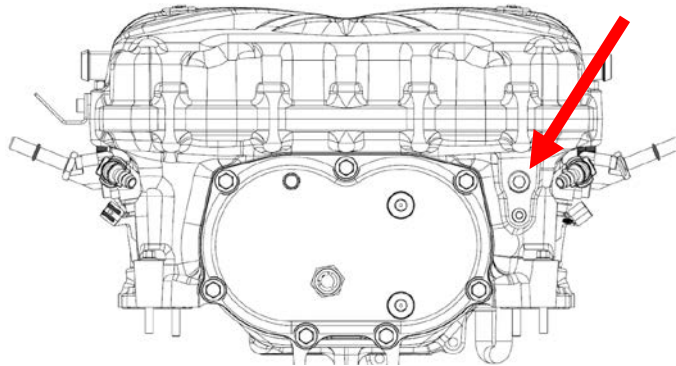

76. Make sure the supercharger is on a flat surface. Remove the oil fill plug using an 8mm allen socket.
 - Fill the compressor to the **CENTER** of the sight glass (**6.8 FL/OZ**). Rock compressor back and forth. Then spin the compressor/rotors by the pulley so the oil fills the bearings. **NEVER OVER FILL THE SUPERCHARGER!**
 - Apply light amount of grease to oil fill plug oring, reinstall. Torque to 140 lbs-in.

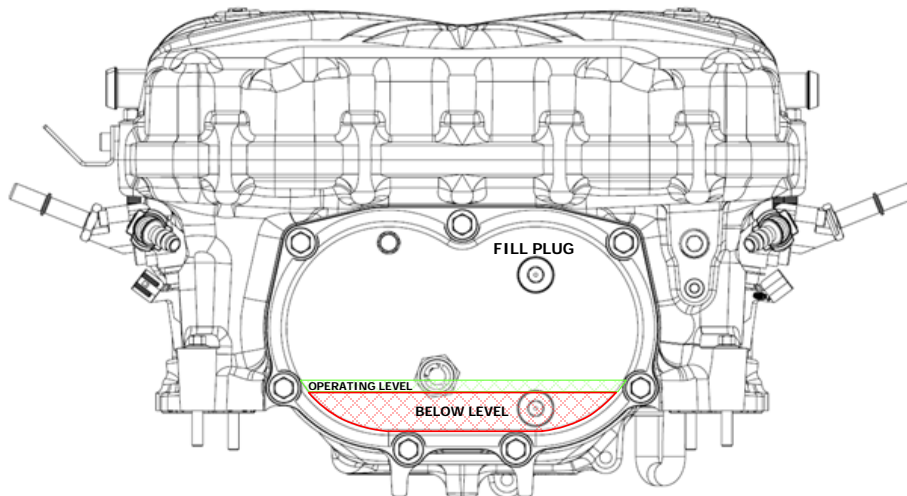

77. Install the supercharger housing (without lid) to the engine. Use the supplied (4) 6mm x 55mm HHFCS on the outer bolt holes and the (6) 6mm 55mm HHFCS bolts with the supplied (6) #2-009 orings on the bolt, under the head. Use **Blue Loctite #243** to the threads of each bolt. Leave hand tight for now.



78. Using a 6mm allen socket, secure the (1) 8mm x 70mm SHCS and (1) 8mm x 25mm HSCS to the front support bracket. Torque to 22 lbs-ft.

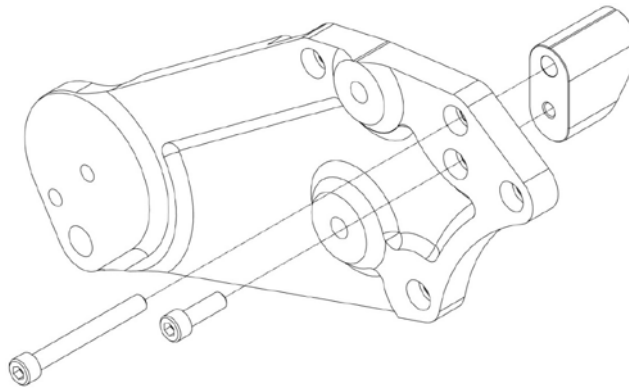

79. Torque the (10) 6mm x 55mm HHFCS manifold bolts in the following pattern using a 10mm socket. First pass: 88 lbs-in. Second pass: 106 lb-in. **NOTE:** For bolt #10, a 1/4" socket with 4"-6" extension, 10mm wobble is the best possible tool to get into this tight area.

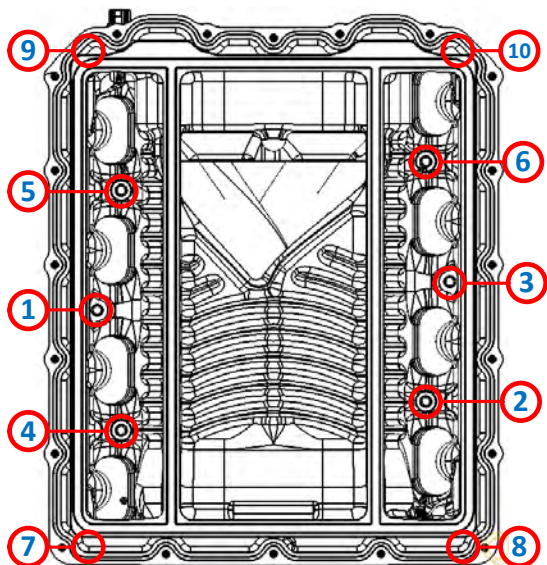

80. Install the supplied (4) #2-015 viton oring to the (2) fuel rail adapters. Apply light amount of grease to the orings. Install the fuel rail adapters to the fuel rails using the supplied (6) 5mm x 20mm SHCS, apply light amount of Blue Loctite #243 to the bolt threads. Torque to 75 in-lbs using a 4mm allen socket. **TIP:** Many orings are provided and some look similar, ensure that you are using the correct size in each step.



81. Using a 27mm socket, remove the fuel PSI sensor from the factory fuel rail. Install the factory fuel PSI sensor to the adapter using a 27mm socket. Torque to 53 lbs-in, then an additional 25-degree rotation. **NOTE: No sealant on the threads.**



82. Install the supplied (1) #2-906 Viton oring to the (1 of 2) 45mm long 9.49mm inlet fitting. Apply light amount of grease to oring for ease of installation. Install fitting to the fuel inlet block.



83. Install the supplied (1) #2-906 Viton oring to the (1 of 2) 45mm long 9.49mm outlet fitting. Apply light amount of grease to oring for ease of installation. Install fitting to the fuel inlet block. Install the supplied -6 ORB plug to the extra port.



84. Install the supplied (2) #2-906 orings to the (2) inlet/outlet fittings. Install these (2) fittings into rear side of fuel rails. Apply light amount of grease to oring for ease of installation. Using a 3/4" wrench (or 3/4" deep socket) on both the front and rear fittings, tighten both.



85. Install the fuel injectors to the fuel rail, apply generous amount of grease to oring for easy installation. Install the supplied fuel injector position lock bracket to clock the supplied fuel injectors into proper position (competition kits with other injectors do not apply). While installing the lock bracket, secure the fuel injector so it does not add pressure to the injector body. **Note:** This is for dual spray pattern injectors only that must be at the correct angle. **Competition** kits should consult their tuner to verify whether the injector has to be clocked at a certain position (single spray pattern injectors do not). **TIP: Failure to clock the injector correctly can cause severe running issues.**

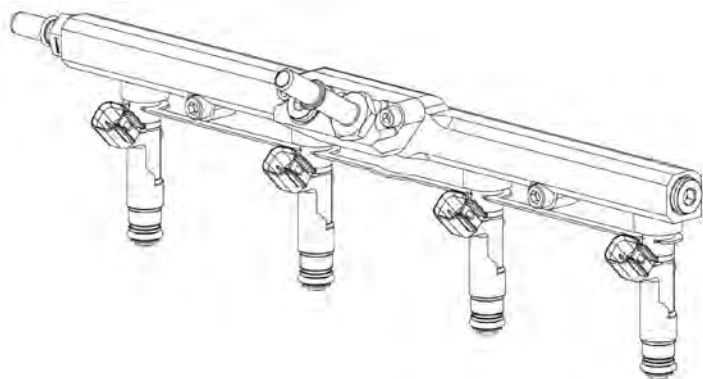

86. Apply generous amount of grease to the injector orings for ease of installation. Install the fuel injectors, rails and lock bracket to the intake manifold, secure with the (4) 6mm x 20mm SHCS using a 5mm allen socket. Torque to 90 lbs-in.



87. Install the supplied fuel cross over line around the back of the supercharger by pressing until they click and lock in place.

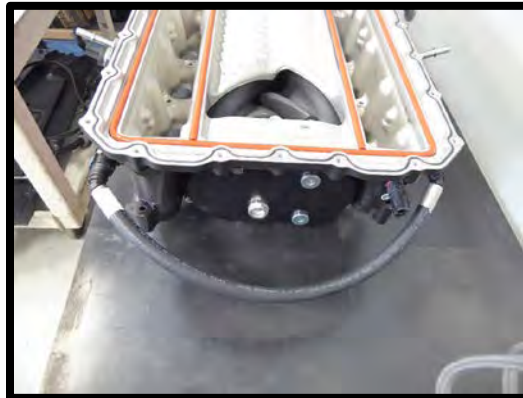

88. Using the supplied 5/16" OD silicone tube, install the (1) 60 1/2" cord around the perimeter receiver groove. Bunch it up so it has no gap at the end. Install the (2) 16" cords in the two middle sections, making sure it bunches up to perimeter cord. There should be no gaps.



89. Install the supplied pre-formed 20.7" x .103" oring to the top sealing surface of the SC housing. Apply generous amount of grease to help ease the oring into place. **TIP:** To install oring into dove-tail groove, press vertically, vs sliding finger along.

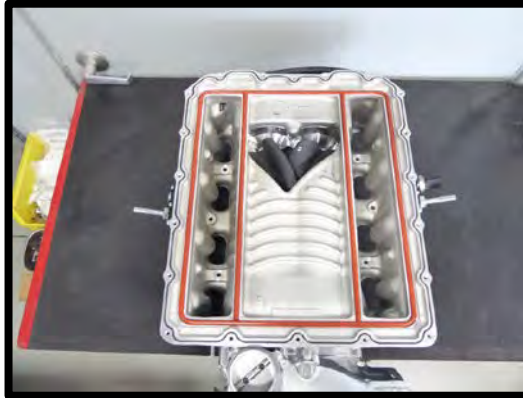

90. Install the (1) #2-230 internal bypass oring to the lid bypass passage. Use generous amount of grease to secure oring in place.



91. Apply generous amount of grease to the (1) #2-230 Viton bypass oring. Install the supercharger lid to the supercharger housing by carefully placing the bypass down. Secure the SC lid using the (17) 6mm x 30mm HHFCS and (3) 6mm x 70mm HHFCS (*marked green*) using the following pattern. Torque to 90 lbs-in using an 8mm socket.

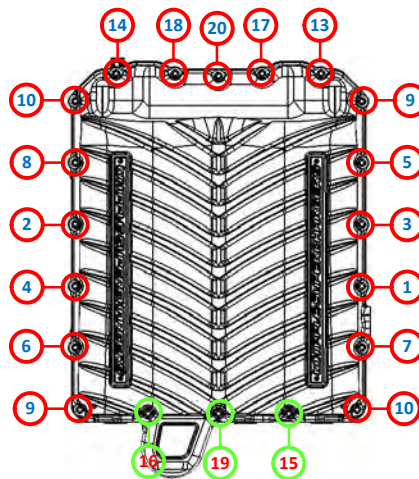

92. Install the supplied (3) intercooler cross-over inlet/outlet fittings and mounting fork to cross-over. Apply light amount of grease to orings for proper installation. Use the supplied (2) 6mm x 10mm HHFCS to secure mounting fork. Torque to 85 lbs-in using a 10mm socket.

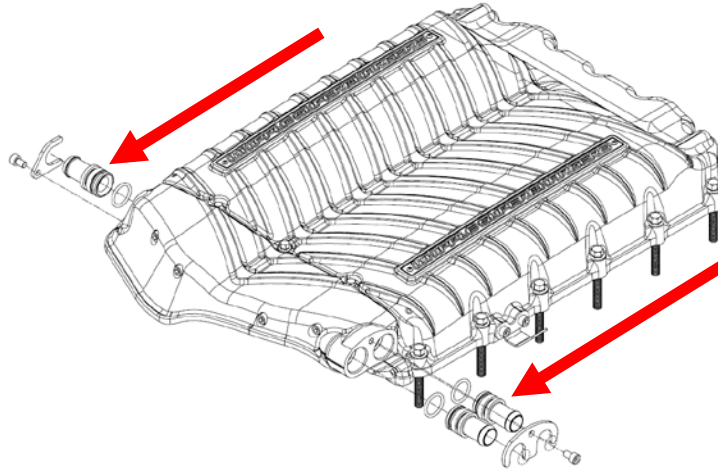

93. Connect the factory passenger side rail fitting to the DI pump factory hose, press until it clicks and locks in place.



94. Connect the factory fuel inlet line to the driver side fuel fitting, press until it clicks and locks in place.



95. Connect the factory fuel PSI sensor connector to sensor, press safety lock until it clicks and locks in place.



96. Install the supercharger pulley using the supplied (4) 6mm x 14mm SHCS using a 5mm allen socket. Leave hand tight until belt installation.
97. Install the supplied supercharger belt by following the routing diagram. Once in position, lock the adjustable idler pulley by torquing the SHCS to 30 lbs-ft. **NOTE:** Set the tensioner position so the two arrows are aligned (80% travel) by removing slack via the adjustable idler pulley. If setup at max open position, the tensioner will consistently hit its stop. If setup near its full close position, then the tensioner will not continue to apply torque to the belt during belt stretch and will allow it to jump or walk.

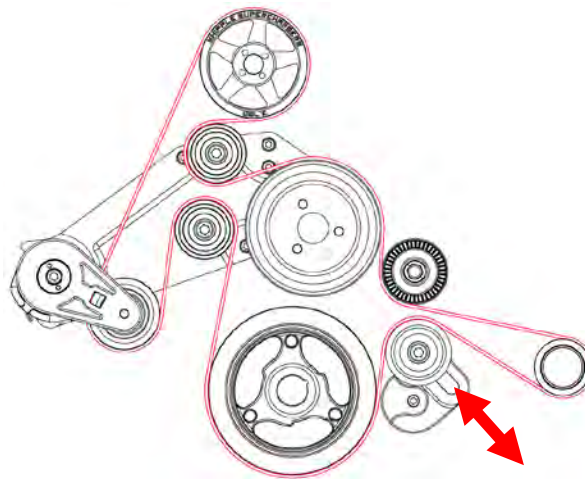

98. With the belt holding the SC pulley in position, torque the supercharger (4) 6mm x 12mm SHCS bolts to 130 lbs-in using a 5mm allen socket. Do not use Loctite on threads, it is not required.
99. **(Complete Kits Only)** Connect the previously installed ACT pigtail (IAT2 manifold air temperature) to the pre-installed ACT sensor located on the driver side of intake manifold. **Competition Kits:** ACT pigtails are not included.

100. Mustangs equipped with the Performance Package must remove the (2) front support braces connecting the front bumper support to the upper radiator support. Remove the (3) bolts per bracket and remove brackets from vehicle.

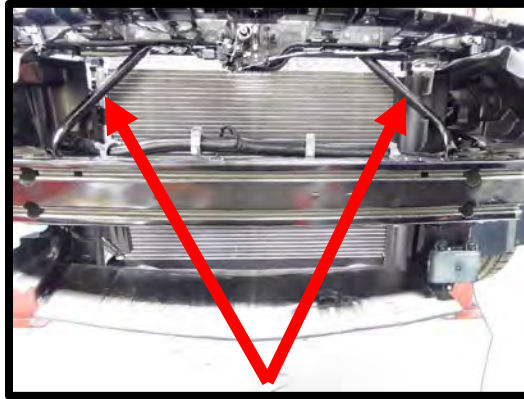

101. Using a panel puller, remove the (1) plastic pin holding the front snorkel to the radiator support. Using a hacksaw, cut the one side off as shown. Once cut, reinstall closeout using original plastic push pin.

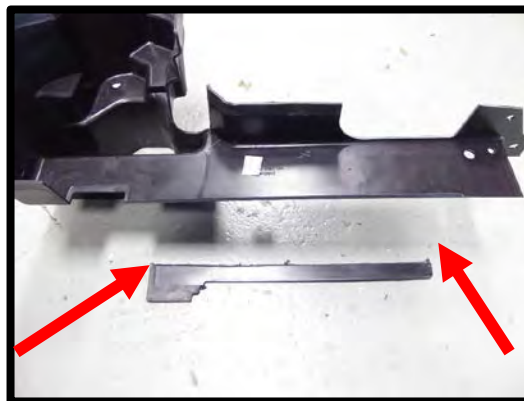
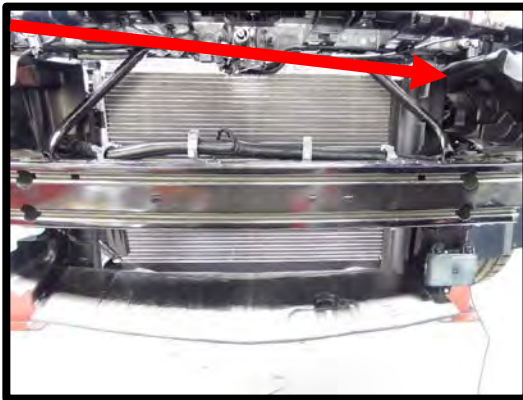

102. **(Dual fan installation)** Install the (8) supplied rubber feet to the fan mount bosses.

103. **(Dual fan installation)** Install the supplied (4) rubber strips to the bottom flat portion of the fan mount brackets. Clean the brackets with soap and water. Remove the protective tape from the rubber strip and install to the bracket.

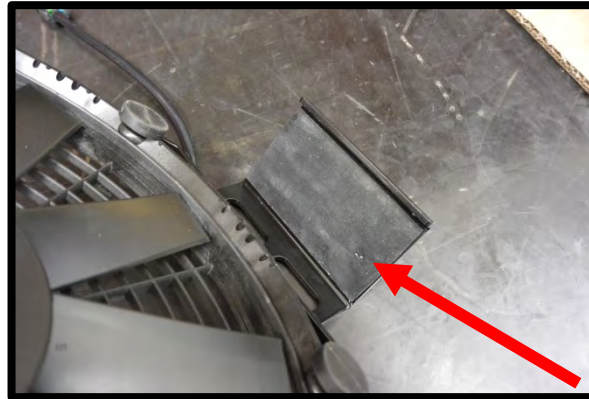

104. **(Dual fan installation)** Install the (4) brackets to the fans by sliding the square tab into the fan notch and the steel channel bracket will slide on the outside. The angled side will face the fan. This slides together easier if the bracket is facing slightly up. Once these are lined up, push until the seat together. Repeat on the other (3) brackets. Leave nyloc nuts loose for now.



105. **(Dual fan installation)** Carefully set both fan assemblies on top front of the LTR, space these evenly before installing.



106. **(Dual fan installation)** Carefully pull open brackets and push onto the LTR. Its best to do both ends at the same time otherwise the bracket can be at an angle and hard to get on. NOTE: Electrical connectors should face down.
107. **(Dual fan installation)** Carefully snug up the (8) nyloc nuts using a 1/4" ratchet and 10mm socket. Do not over tighten.
108. Install the supplied (4) rubber grommets to the LTR mounts. Install the supplied (4) aluminum LTR spuds to rubber grommets installed in LTR.

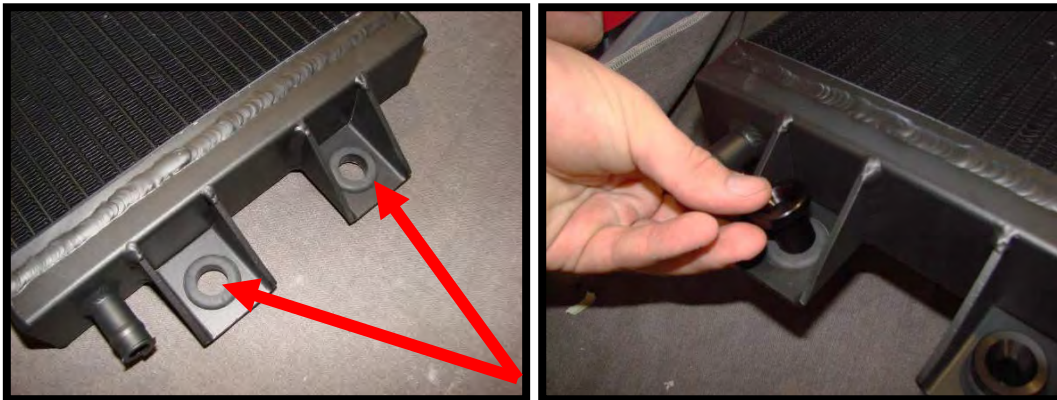

109. Install the LTR brackets to the LTR using the supplied (4) 8mm x 35mm FHSCS bolts through the aluminum heat exchanger spuds (5mm allen socket).

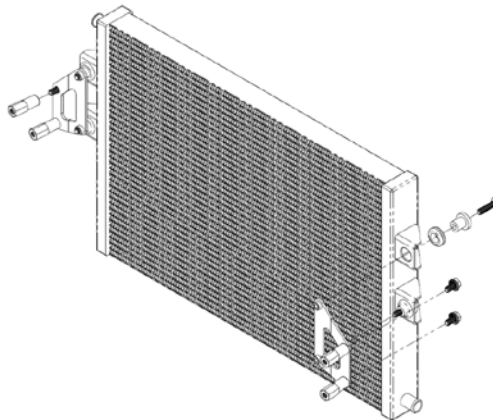

110. Install the supplied (4) hex coupling nuts to the factory bolt threads on the back side of the front bumper support (2 driver side, 2 passenger side) using a 16mm wrench.



111. **(HD LTR installation)** Remove the factory plastic support clamps from the wire harness. Use a flat blade screw driver to open. Use a plastic pin pry tool to remove the clamps from the vehicle.

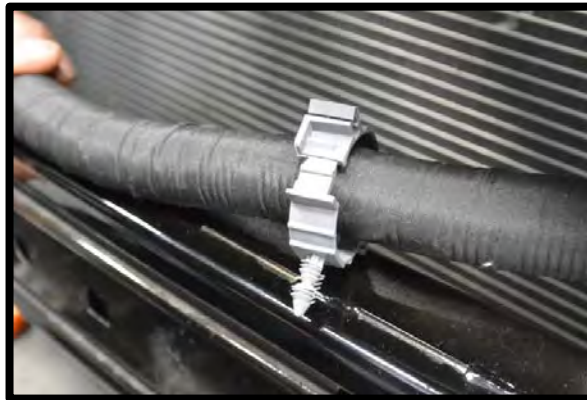

112. Slide the LTR assembly up from the bottom. Connect the LTR brackets to the coupling nuts using the supplied (4) 8mm x 16mm hex headed flanged bolt (13mm ratchet wrench).
113. **(Dual fan installation)** Use the original plastic zip-tie push pin into the 2 inner most holes. Use (2) new zip-ties to secure harness back in place. Push harness back in between brace and dual fans.



114. With the LTR mounted, mark the centerline of the LTR fitting and horizontally center of the plastic radiator (passenger side) shrouding. Using a 1 1/2" hole saw, drill a hole through the plastic shrouding. Install the supplied 1 1/2" rubber grommet into this hole. **NOTE:** Install hole and grommet as close to the plastic edge as possible. This gives proper clearance on the opposite side for the Y fitting.



115. Route the supplied 90deg intercooler feed hose #COYO-2006 through the grommet, cut to fit as needed. Install the supplied Y fitting to the end of the hose from the outlet of the LTR, just after the grommet. Secure hose to fitting with pinch clamp.

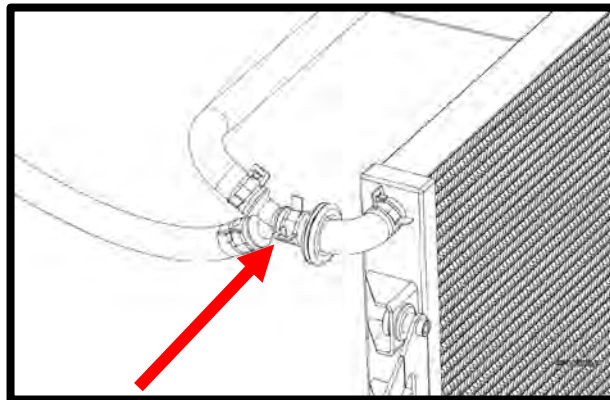

116. Connect the 3/4" x 34.5" #3102697 hose to the Y fitting, secure with pinch clamp. Route other end to the RH side of the water cross fitting. Secure with the supplied worm clamp. For max hood clearance, ensure that the hex is not on top.

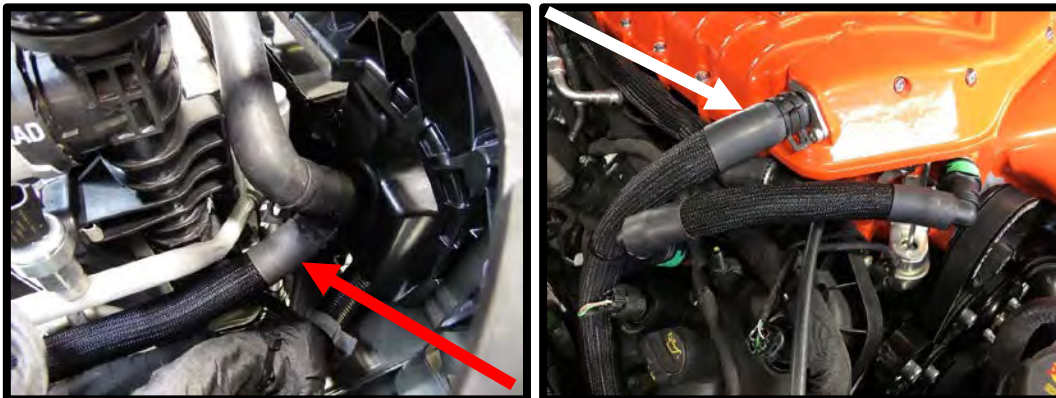

117. Install the supplied preformed $\frac{3}{4}$ " x 48" dual 90deg hose #3102698 to upper Y fitting and secure with pinch clamp. Route up and over the condenser to LH side of vehicle. Leave this end loose until airbox installation. Secure hose to factory holes using zip-tie to prevent hose from sitting on AC Condenser.

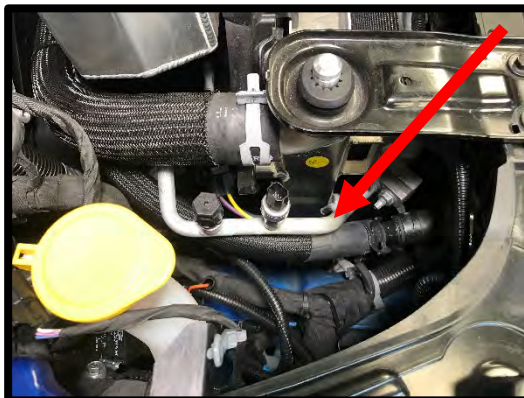

118. Install the intercooler pump to the water reservoir using the supplied clamp and rubber strip (leave slightly loose to position after hose installation) and the (2) 6mm x 10mm HHFCS. Install the supplied U-bend rubber hose and pinch clamps to reservoir and intercooler pump. Once pump is in position, tighten clamp holding IC pump to reservoir. Note: Make sure pump outlet is facing up and towards the pump as shown. Once pump is in place, install the supplied 90deg hose from the reservoir to pump. Secure both ends with pinch clamp.

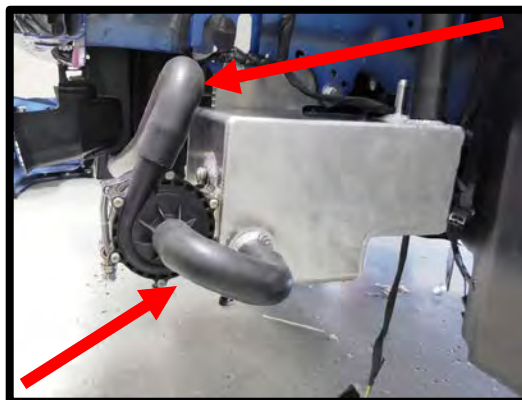
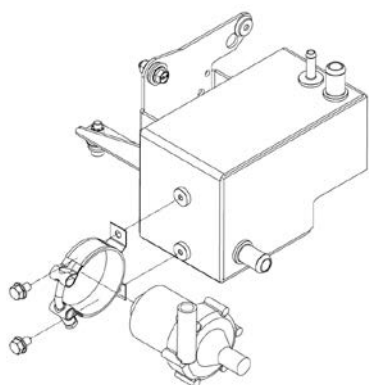

119. Install the supplied (3) rubber grommets into the 3 mounting holes. Install reservoir to vehicle by first sliding mounting bracket over factory stud. Secure to stud with the 6mm AN washer and nut, leave loose for now. Install the 8mm x 25mm flanged hex head bolt, 8mm AN washer, .375" bushing to the factory mount, leave loose for now. From the bottom side, install the 8mm x 30mm SHCS AN washer through the frame. Secure top side with the .375" bushing and 8mm nut. Once tank is in place, secure all 3 fasteners.

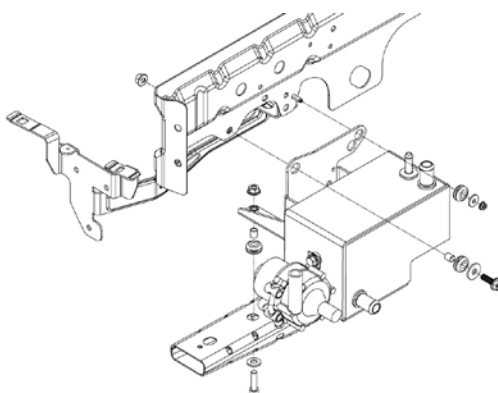

120. **(Standard LTR)** Using a hacksaw, notch the plastic shrouding next the heat exchanger inlet fitting. Use the supplied $\frac{3}{4}$ " ID x 20" hose with 90deg end for test fitting (from pump outlet to LTR inlet).



121. **(Standard LTR)** Route the $\frac{3}{4}$ " ID x 16" hose from IC pump outlet to LTR inlet. This hose has to go up and towards the tank as shown in the image. Failure to do so may cause clearance issues.

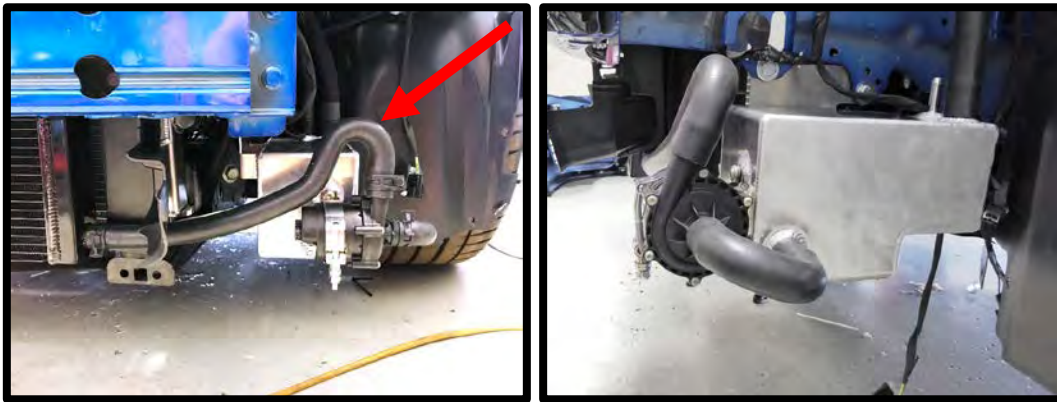

122. **(HD LTR)** Use the supplied $\frac{3}{4}$ " coupler and (2) pinch clamps to couple the $\frac{3}{4}$ " x 20" hose to the $\frac{3}{4}$ " x XX" extension. Route the 180deg end to the LTR inlet. Secure using pinch clamp.

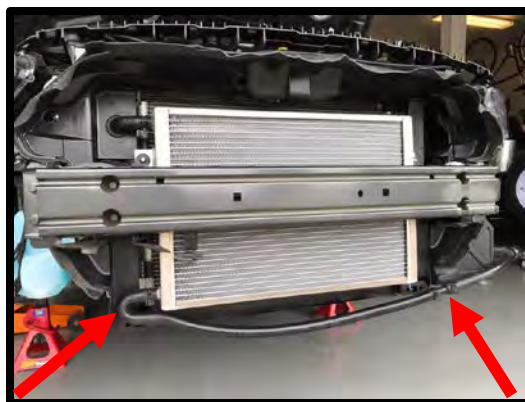

123. Mount the EECPV bracket to SC lid, use the (2) supplied 6mm x 10 HHFCS. Torque to 80 lbs-in using a 10mm socket.

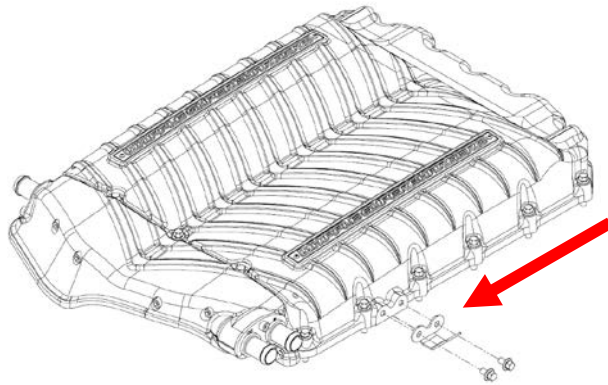

124. Slide the EECPV to bracket by sliding onto bracket. Connect factory plastic quick connect fitting to EECPV until it clicks and locks into place. Connect 2-way electrical connector to EECPV, press locking tab back in place.



125. Install the supplied 1/4" ID bypass actuator to the bypass nipple and 1/4" nipple on SC housing. **CAUTION:** Do not open/close bypass actuator by hand. This may damage actuator internally. It only moves properly with equal vacuum/boost at the actuator reference port.



126. Install the (2) supplied 6AN viton oring (#906) to the (2) 6AN to 3/8" quick connect fittings. Install these fittings to the passenger side lower 6AN fittings on the inlet using an 11/16" socket.

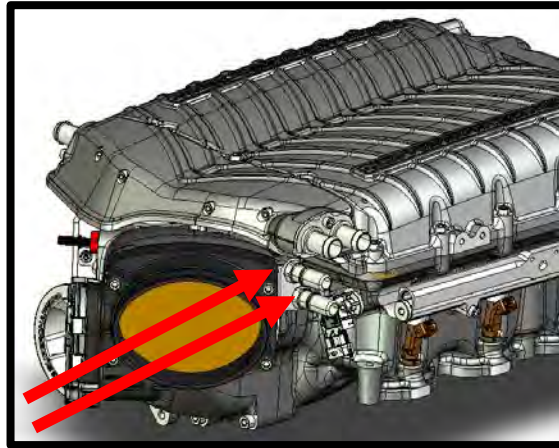

127. Install the supplied 3/8" ID x 24" brake aspirator hose from the brake booster to the **lower** quick connect fitting on the supercharger inlet. Push until it clicks into place. **TIP:** For best routing, nestle in between cam cover and fuel rail, under the wiring and heater hose.

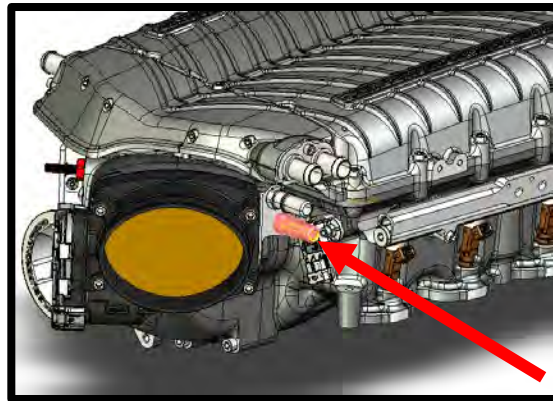

128. Install the supplied 3/8" ID x 5 1/2" hose factory EECPV barb fitting and **upper** quick connect fitting on SC inlet. Push until it clicks and locks into place.

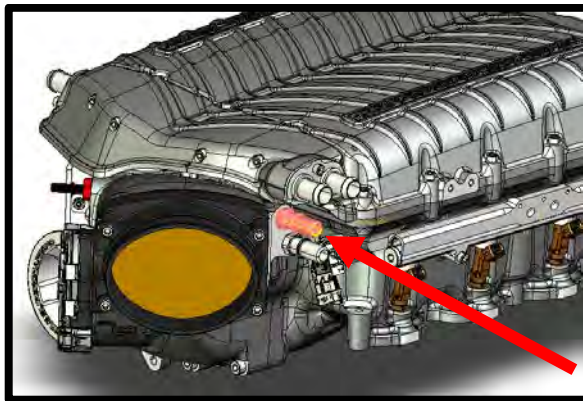

129. Install the (1) supplied 6AN viton oring (#906) to the (1) 6AN to 5/8" quick connect fittings. Install this fitting to the driver side 6AN fittings on the inlet using a 7/8" wrench.

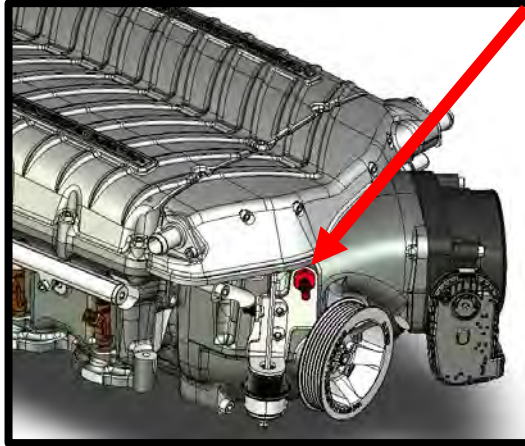

130. Install the supplied 5/8" ID x 8 1/2" hose to the passenger side valve cover. Connect other end to the supercharger inlet quick connect fitting. Push until it clicks and locks into place.



131. Install the supplied 5/8" ID x 21" hose to the driver side valve cover. Push until it clicks and locks into place. The other end will be installed in inlet tube later.

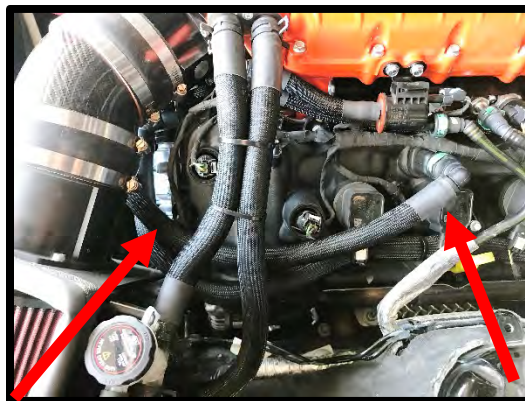

132. Install the supplied $\frac{3}{4}$ " ID molded hose (#COYO-1300) from the IC **OUT** fitting to the airbox area for later installation. Secure end with supplied worm clamp. **TIP: For hood clearance, ensure that the nut of the clamp is not on top.**

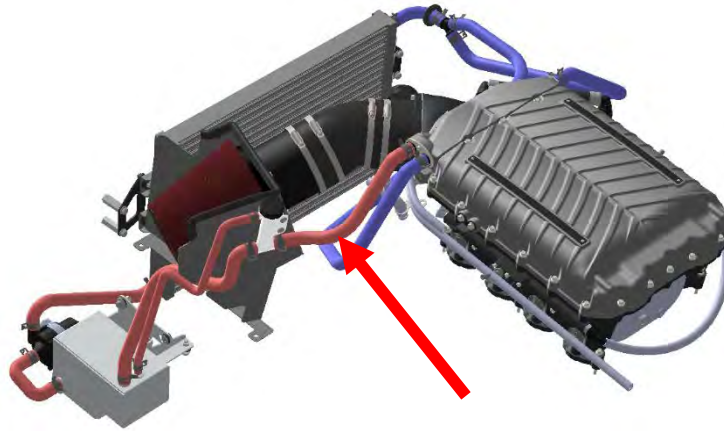

133. Install the supplied electronic throttle pigtail to the factory electrical connector. Push until it locks in place, then lock the safety lock. **TIP: When pressing together, hold the wires vs connector to ensure the wires do not come loose during connection.**

134. Using the supplied MAF housing and 123mm plastic venturi ring, mount to the new cold air box with the (4) 6mm x 16mm SHCS (5mm allen ball socket). Torque to 75 lbs-in. Install the rubber sealing material to top edge of airbox.

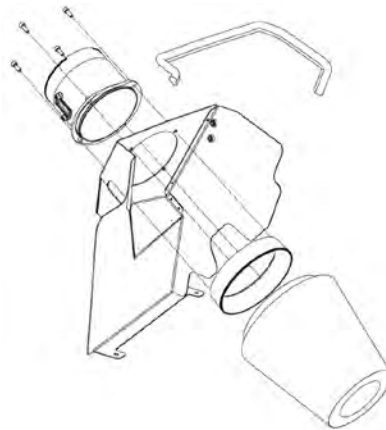

135. Install the factory MAF sensor element into the new MAF housing using the supplied (2) 4mm x 6mm SHCS. Torque to 17 lbs-in. ****DO NOT USE STOCK BOLTS****. ***TIP: Verify arrow position for airflow direction.**



136. Install the high-flow air filter and clamp over the 123mm venturi ring. Once in place, secure hose clamp using a 5/16" nut driver. Drop airbox into position in vehicle. Secure box to frame by using the stock (2) plastic push pins at base of the box.

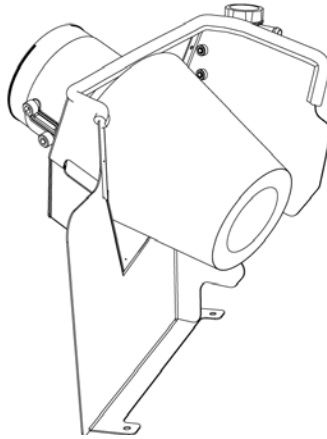

137. Install the intercooler filler neck to the (2) aluminum threaded stands using the (2) 6mm x 45mm BHFCs (4mm allen socket).

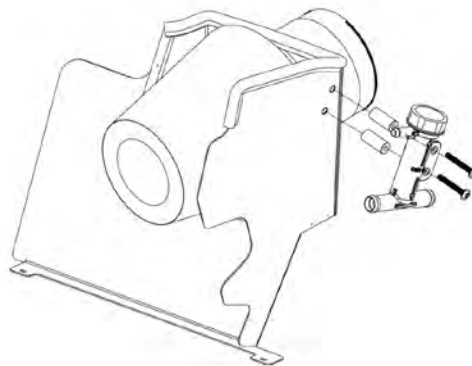

138. Connect the 3/4" ID molded rubber hose you previously installed to the IC (OUT) fitting and connect to the IC filler neck. Secure with supplied pinch clamp.

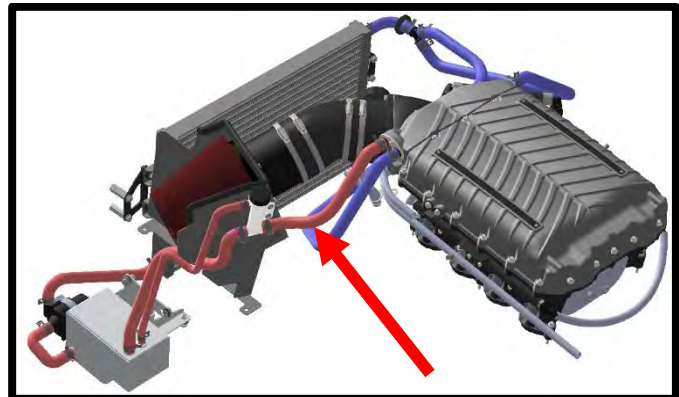
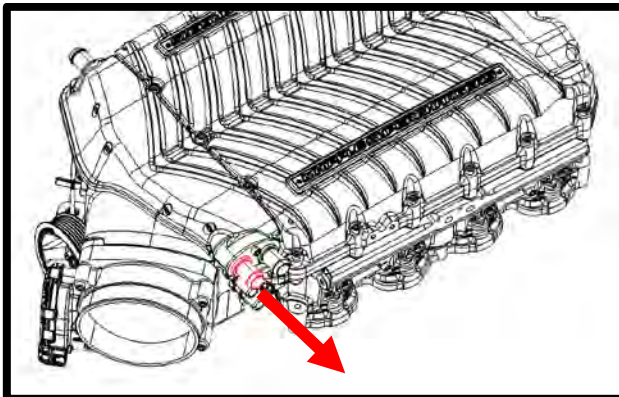

139. Install the supplied 3/8" ID x 31 1/2" IC vent line (COYO-1400) and the 3/4" ID x 24 1/2" IC rubber hose (COYO-1300) to the filler neck. Both use the 90deg on the filler tee. Secure both with supplied pinch clamps. Route both below the airbox, to the IC reservoir. Secure both ends with supplied pinch clamps. Use multiple zip-ties to secure hoses together. **Watch for hose kinks!**

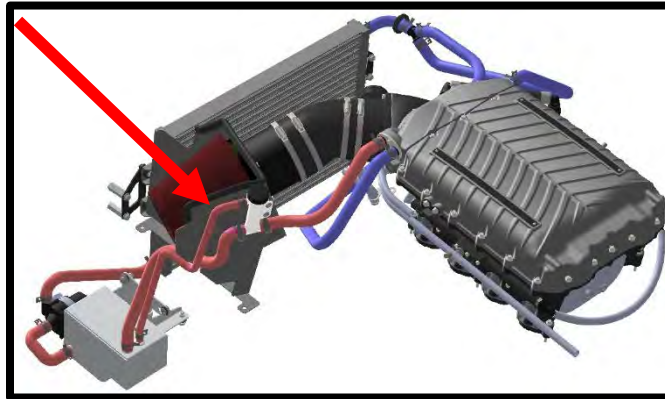

140. Install the previously routed hose from the Y fitting, to the LH core inlet fitting. Secure with worm clamp. **TIP: For hood clearance, ensure that the nut of the clamp is not on top.** Secure inlet and outlet lines with zip-ties for clean installation.

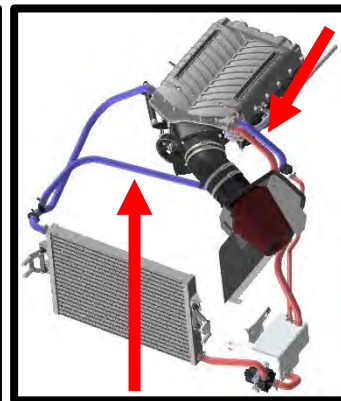
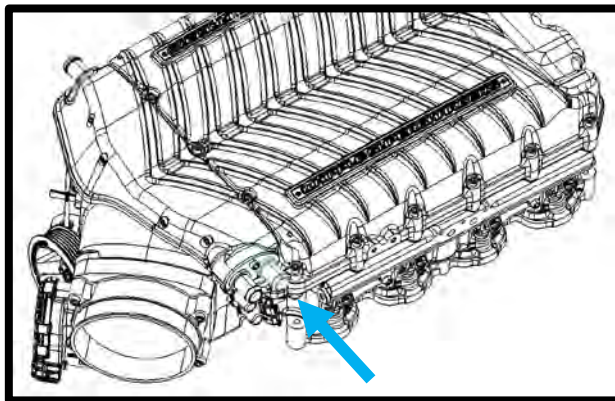

141. Install the (1) 5" ID x 2 1/2" silicone hose with dual #80 hose clamps to the MAF housing. Leave loose for now. ****Never over torque the clamp to secure the silicone hose to the MAF housing, this can distort the MAF and lead to running issues.**

142. **(Stock throttle body)** Install throttle body adapter to supercharger inlet using the supplied (4) 6mm x 14mm FHCS (4mm allen socket) using the supplied gasket between TB adapter and SC inlet. Torque to 88 lbs-in.



143. Install the stock throttle body using the (4) 6mm x 50mm FHSCS bolts using a 10mm socket.



144. (**Whipple 132mm Crusher throttle body**) Install throttle body to supercharger inlet, use the supplied gasket between TB adapter and SC inlet. Secure with the supplied (3) 6mm x 25mm SHCS and (1) 6mm x 50mm SHCS using a 5mm allen socket. Torque to 88 lbs-in.



145. Install the supplied $\frac{3}{4}$ " grommet into air inlet tube $\frac{3}{4}$ " hole. Install the supplied $\frac{1}{2}$ " to $\frac{5}{8}$ " quick connect aluminum fitting into grommet hole.

146. Secure driver side vent line quick connect fitting to the $\frac{5}{8}$ " fitting in the inlet tube previously installed.



147. Connect the previously routed 1/4" vent line to the stock overflow tank, secure with stock clamp. Secure this hose to the radiator hose and heater hose using multiple zip-ties.



148. (**Whipple 132mm Crusher throttle body**) Install the supplied 5" ID x 2" silicone hose over air inlet tube so it's not hanging over the end. Install the air inlet tube between the MAF and throttle body. Slide silicone hose over throttle body. Secure all ends with the supplied #80 hose clamps. **Never over torque the clamp to secure the silicone hose to the MAF housing, this can distort the MAF and lead to running issues. 45-55 lbs-in is recommended.

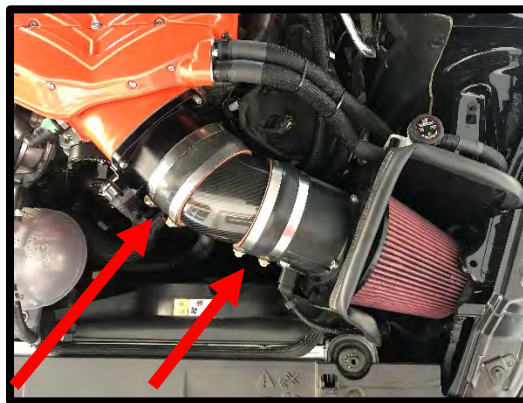

149. (**Stage 2 and Up Systems**) Locate the supplied DW400 fuel pump kit.



150. **(Stage 2 and Up Systems)** Remove the OE pump connector harness and fuel level sender.



151. **(Stage 2 and Up Systems)** Cut the smaller venturi outlet hose (1/8" ID) and remove the center section of the assembly by depressing the (3) tabs (circled in green) around the perimeter and pulling the center up and out of the bucket assembly.

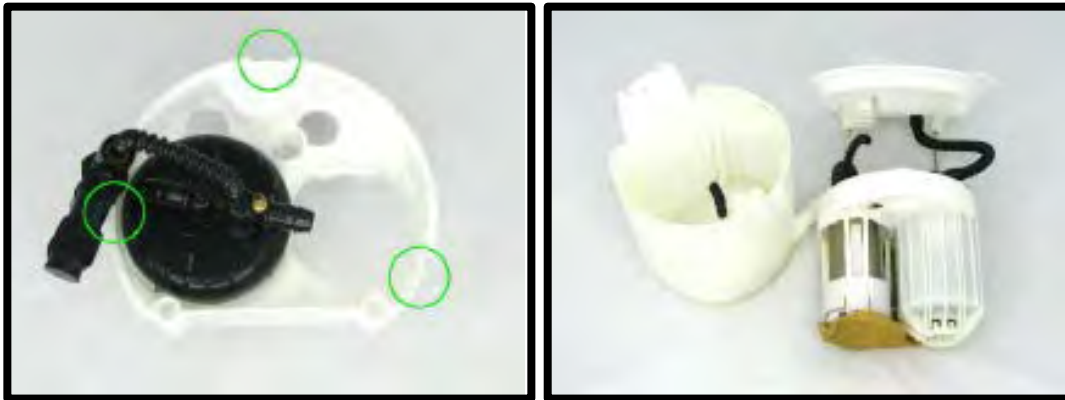

152. **(Stage 2 and Up Systems)** Carefully cut the larger pump outlet hose (3/8" ID) from the assembly filter and remove the OE pump.



153. **(Stage 2 and Up Systems)** Remove the (3) locating tabs and smooth the pump receptacle to the diameter of the DW400 (46mm).

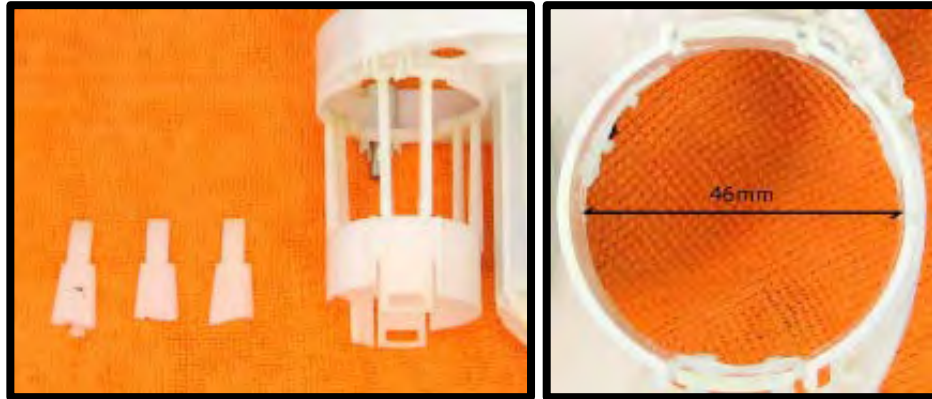

154. **(Stage 2 and Up Systems)** Install the 3/8" tube onto the assembly filter inlet and slide on the (2) hose clamps. Install the DW400 into the pump receptacle and install the 1/8" hose onto the venturi inlet receptacle of the assembly bucket.



155. **(Stage 2 and Up Systems)** Install assembly center section into the assembly bucket and connect the 3/8" tube to the outlet of the pump, then tighten the hose clamps. Slide the larger permanent clamp (13/32") onto the hose and crimp it in place (over the barbs) with a pair of side-cutters. Slide the smaller permanent clamp (11/32") on the hose and install the free end on the smaller venturi outlet on the pump. Crimp the clamp in place under the barb. NOTE: Removing the assembly top-hat from the assembly center section will allow for more room to work to install the components.



156. **(Stage 2 and Up Systems)** Install the new connector harness supplied with the DW kit, the additional static ground inserts into the slot on the assembly filter, the same as OE.



157. **(Stage 2 and Up Systems)** Reinstall the hat to the assembly in the center/buckets assemblies and connect the electrical connector harness to the hat assembly.



158. **(Stage 2 and Up Systems)** Reinstall the assembly into the fuel tank and attach a length of hose to the outlet of the pump assembly allowing it to drain into a fuel safe container and prime the fuel pump assembly. Attach the supply line to the outlet of the pump assembly.

159. Reinstall the factory K-Brace by lifting up the cowl trim panel and sliding the K-Brace underneath. Reinstall the K-Brace over the studs and into position on the vehicle. Install the (2) nuts on the studs and torque to 25 Nm using a 15mm socket. Install the (5) mounting bolts and torque to 25 Nm using a 13mm socket. Reinstall the (7) pushpin retainers on the cowl trim panel.

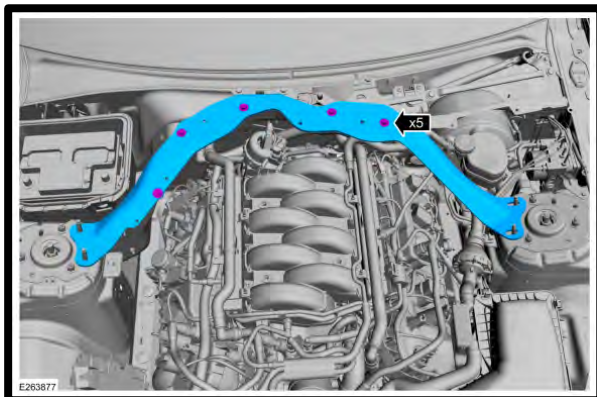
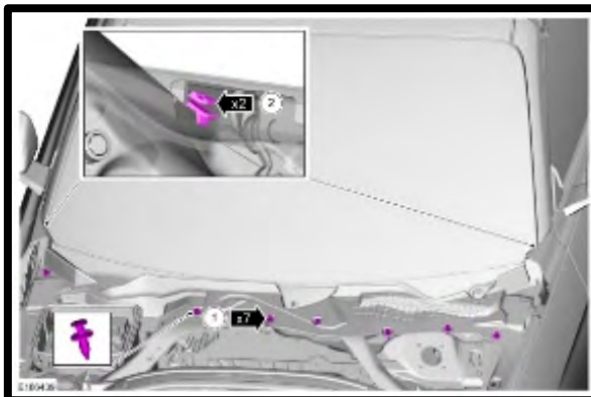

160. Refill the Engine coolant. Verify that your coolant drain is closed, use a filter/strainer to pour the recycled coolant/water mixture that you drained from the radiator. If necessary top off with a **Ford approved engine coolant**. Whipple also recommends running 2 bottles of Redline Water Wetter which can be found at most automotive parts stores. **⚠ WARNING!! DO NOT USE TAP WATER OR ANY NON-FORD APPROVED ENGINE COOLANT, THIS WILL CAUSE CORROSION IN THE SYSTEM. ** (Vehicles that come equipped with Ford Motorcraft Orange should use Motorcraft Specialty Orange.**
161. Attach the negative cable to the battery and tighten using an 8mm wrench.
162. **(Complete kits)** Install the supplied 50-state legal sticker (when applicable) to the hood as the factory emissions sticker. Use light amount of acetone to clean surface before installing.
163. Attach the "91 OCTANE OR HIGHER" decal to the gas tank fill cap or door.



The electric water pump used on the Whipple SC system has a built-in micro-processor that will vary pump cycle speed when air bubbles are present in the system. If a significant amount of air is trapped in the system, the pump may cycle at a lower speed and pulsations are likely to occur resulting in poor cooling performance.

For the best result, it is highly recommended to use a Radiator Cooling System Vacuum Purge and Refill Kit to properly evacuate the air from the intercooler system before filling the 50/50 mixture of coolant and distilled water. If one is not available, the following procedure will be adequate.

164. Using a Lisle 24680 Spill-Free Funnel, or equivalent, secure the appropriate filler neck adapter to the filler neck/surge tank.
165. Attach the funnel and fill with a 50/50 mixture of coolant and distilled water until the funnel is half full. Whipple recommends Ford Motorcraft Orange or Zerex G-05 to match the stock color. Whipple also recommends 1 bottle of Red Line Water Wetter or equivalent. Note: The Whipple IC system is compatible with all common types of antifreeze. Never use tap water, this will cause corrosion and destroy the system.
166. Turn the ignition to the ON position and listen for the pumps electric motor to cycle. Air bubbles will begin to purge from the system as the coolant level drops. Add coolant to the funnel as necessary. Note: Do NOT let the coolant level in the funnel run empty as this may introduce air into the system.
167. To build more pressure in the intercooler system, try squeezing the intercooler hoses while the pump is cycling. Building pressure in the system will help purge the trapped air from the intercooler system. It can also help to lift the filler neck 4"-8" higher than its mount to help purge the air.
168. Cycle the ignition OFF and wait a few seconds for the pump to stop.
169. Cycle the ignition to the ON position again and repeat until the sound of the electric pump is continuous without any pulsation. **NOTE: During water pump start-up, it is normal for a slight pulsation to occur. Once the pump has reached its maximum cycle speed, no pulsations should be present. If any pulsations occur, there is air in the system.**

170. Periodically inspect the water pump flow after a few drive cycles and re-fill the intercooler system as necessary.
171. Several drive cycles may be required to completely purge the air from the intercooler system. During a drive cycle, the intercooler system will build up pressure as the supercharger temperature increases. Any residual air trapped in the system will gradually bleed out of the surge tank when the cap is removed. Use a rag when removing in case there is excess pressure. **TIP: Never go WOT until air has been bleed from IC system, engine failure could occur if not bled properly.**

WARNING: Always avoid removing the filler neck cap when the system is hot. The hot coolant is under pressure and may spray out causing burns.

172. Before driving, make sure that you have 91 or higher-octane fuel in the system (RON+MON)/2. Not ½ tank of 87 and ½ tank of 91, all 91 or better fuel in the system. Whipple does not recommend octane booster.
173. Do not use aftermarket air filter box or duct with the supplied Whipple calibration. The Whipple calibration is designed to work with the Whipple cold air intake system and nothing else. Changes to the air inlet system will require a custom tune which Whipple does not provide.
174. Reinstall front fascia. Reinstall (2) fasteners securing fascia to fender.
175. Reinstall upper radiator shroud using factory push pins (8).
176. Reinstall the lower splash shield to the front fascia using the factory fasteners.
177. Test drive vehicle for the first few miles under normal driving conditions. Listen for any noises, vibrations, engine misfire or anything that does not seem normal. The supercharger does have a slight whining noise under boost conditions, which is normal. If you chose the aftermarket throttle body, idle may take a few minutes to learn.
178. Re-check the radiator and intercooler reservoir coolant level regularly over the first 1,000 miles, top off level as needed.
179. Re-check SC oil level regularly over the first 1,000 miles, level may drop very slightly as it fills the bearings and cavities.
180. Inspect belt system and readjust. It's common for the belt to stretch after first heat cycle.
181. After the initial test drive, go through the belt tensioner process again. On the next test drive, gradually work the vehicle to wide open throttle runs. Listen for any engine detonation (pinging). If engine detonation is present, let up on the throttle immediately. Most detonation causes are low octane gasoline still in the tank.
182. If you have questions about your vehicles performance, please check with your installation facility or call Whipple Superchargers at 559.442.1261, Monday through Friday from 8am to 5:00pm, pacific time or email questions to tech@whipplesuperchargers.com.

⚠ WARNING!! Verify the bypass actuator is working properly. To monitor, look at the bypass arm when the motor is not running. Start engine and verify that the actuator arm has opened. This arm will be extended when the engine is above 2" of vacuum (boost) and will be open when there is more than 3" of engine vacuum. **DO NOT MANUALLY MOVE ACTUATOR, DAMAGE MAY OCCUR!**

There is a great deal of misinformation about the function of supercharger bypass systems. The supercharger is a positive-displacement pump; that is, so long as it is rotating, it is always pumping air. During low demand or high vacuum operation (i.e. idle, deceleration, and light throttle cruise), the pumping action is undesirable as it creates unwanted heat and noise. The bypass circuit, when open, prevents any pressure buildup across the supercharger and allows air to circulate through the rotors, allowing the supercharger to "idle" freely during these conditions. This results in reduced noise, and by reducing heat buildup in the intake, significantly improves street and strip performance. As throttle demand increases, the bypass circuit is closed, resulting in full performance and strip performance. As throttle demand increases, the bypass circuit is

closed, resulting in full performance from the supercharger. The bypass circuit is never used to limit or control boost during full-throttle operation and defeating or altering the bypass function will not result in improved performance in any condition and will result in poor drivability and possible supercharger damage.

MAINTENANCE AND SERVICE

Be sure to follow the maintenance and service recommendations below to optimize the life and performance of your Whipple-supercharged vehicle.

For best performance and continued reliability, it is essential to adhere to the following guidelines:

1. Use only premium grade fuel (91-octane or higher). RON+MON/2. The PCM calibration will automatically detect higher octane levels and will increase power accordingly.
2. Always listen for any sign of spark knock or pinging. If present, discontinue use immediately and consult your vehicle owner's manual.
3. Do not operate the vehicle at large throttle opening if the MIL lamp is on steadily. This indicates an electronic engine control malfunction: reduce throttle opening and consult your vehicle dealer.
4. Check the supercharger oil level at every engine oil change. Add Whipple SC oil to the supercharger if required. Do not overfill the supercharger rear gear case.
5. Change the oil in the supercharger every 100,000 miles. Use Whipple SC oil or Ford #XL-4 only. **NOTE: If spinning the SC faster than standard operation, oil should be changed earlier. Severe damage will occur if oil level is over filled.**
6. Do not operate the vehicle at large throttle opening if the MIL lamp is on steadily. This indicates an electronic engine control malfunction: reduce throttle opening and consult your vehicle dealer.
7. Inspect and clean your high-flow air filter element every 7,500 miles.
8. Inspect and replace spark plugs every 20,000 miles. Only run specified plugs with specified gap.
9. Follow your factory service intervals for oil changes and other typical maintenance items.
10. Check the supercharger/accessory drive belt. Adjust or replace as required

CAUTION: Any modification to your vehicle's new computer program may cause serious damage to the engine and/or drive train. The PCM is locked to the VIN, never let anyone, including dealerships install updates to the PCM. Modifications to the PCM will lock power to stock power levels.

CONGRATULATIONS

Your new Whipple Supercharger is engineered to significantly increase your engines power across a broad range of RPM's. It is Whipple's goal to improve your driving experience for many miles and years to come.

Whipple Superchargers operate as an air pump and contain internal rotors that are driven by the engine's crankshaft and serpentine belts. The supercharger compresses outside air and channels it into the engine's intake ports. Because of their design, superchargers may generate some additional noise over the standard, normally aspirated induction system.

At idle, you may hear a medium-pitch rattle from the supercharger main housing. This will diminish at about 400-500 rpm above idle.

You may also experience a muffled high-pitched whine during acceleration. This is caused by the pumping action of the supercharger compressing air and only occurs during boost conditions. It is inaudible during part-throttle acceleration.

These are normal noises associated with any supercharger and have no effect on supercharger performance or engine durability.

Your supercharger is warranted by Whipple Superchargers, please see your terms and conditions on the back of your invoice for more information in regards to the limited warranty. NOTE: Whipple Superchargers will not authorize any warranty repair work or supercharger replacement for normal noise.

IMPORTANT INFORMATION

DYNO INSTRUCTIONS

7th gear is 1:1 which will show the highest power value on inertia-based dynos on the automatic, 5th gear on the manuals. Always have adequate airflow to the vehicle to avoid overheating. Always cool down for a minimum of 3 minutes between runs to allow the engine to cool off. Always listen for pinging/detonation, if you hear more than one ping, lift immediately.

BOOST LEVELS

All Whipple kits are shipped with boost levels that Whipple feels achieves maximum power while maintaining reliability with stock engines (@ sea level). Additional pulleys are available for lower and higher boost levels, the supplied calibration (complete kits) for the original pulley or larger (lower boost). Higher boost levels must run higher octane levels such as 104, 110, 116, Boostane or be custom tuned. One can always lower boost with no cal changes required.

EXHAUST

Cat-back exhaust systems help reduce heat and minimize exhaust back pressure. They do not affect the calibration and are always a good idea for added safety and performance. Long tube headers and/or high flow cats require custom calibrations and are not supported by Whipple. While they make more power, they greatly affect the tuning and therefore this should be custom tuned by a reputable tuner.

AIR FUEL RATIO

Air fuel ratio is the measurement of the amount of air and fuel being burned during the combustion process. In order for you to monitor the air fuel ratio, you must have a 18mm bung welded into the exhaust or use OBD data logger to monitor the factory wide bands. The ideal placement is pre-catalytic converter as the catalytic converter can give false readings. While in some cases, it may not be possible to measure air fuel pre-cat, one must verify that post-cat that the motor is running at stoich at idle and should technically show .20 to .50 leaner air fuel ratio.

The Whipple supplied calibration has is tuned for WOT .81 Lambda considering 91 octane fuel with 10% Ethanol. Whipple maintains Catalytic saver mode which richens the target air fuel to maintain cat life. During this, the air fuel may lower up to one full point to maintain temps.

FUEL SYSTEM

The Whipple fuel system (FLOW) needs no additional changes for power levels supplied by Whipple. Any smaller pulley changes, custom calibration or custom engines may require fuel system changes. Use the chart below for fuel system performance. Whipple programmable fuel pump boosters should be used when stated below.

	37lb/hr	Pump Upgrade	Octane Required
4.00"	OK	No	91 or higher
3.875"	OK	Yes	91 or higher
3.75"	OK	Yes	93 or higher
3.625"	OK	Yes	95 or higher
3.50"	OK	Yes	98 or higher

FUEL OCTANE

There is a large variance in quality of fuels. Top Tier fuel is from large name brands such as Shell, Chevron, Unocal, Sunoco, Texaco, Phillips and others. Secondary fuel is common from grocery chains, liquor stores and small convenient shops. Never run fuels from secondary suppliers. Never run a fuel octane that is below 91octane, (RON+MON)/2 and never run fuel with more volume than 10% Ethanol (E10). It is recommended, when available, to run 92-94 octane. Never mix mid-level (below 91) with 91+, this is very dangerous and can cause severe engine damage. Do not attempt to increase octane ratings with generic octane boosters, these are very hard on spark plugs and many brands do very little to the actual octane rating (1 point is .1 octane). For emergency situations and racing applications, the best octane booster found to date is Boostane (#1 choice). Some other brands are hard on spark plugs so constant use will require increased spark plug maintenance. The PCM constantly adapts, if it senses better fuel, it will increase power accordingly.

ENGINE COOLANT

Whipple recommends running a 50/50 mix of distilled water and coolant (race applications should run 70/30). The engine coolant temp should run between 200-210deg F under normal driving conditions. The fans are turned on at an earlier temp to promote cooler operating temps. We also recommend 1-2 bottles of Red Line Water Wetter coolant additive. This will reduce air bubble insulation, which increases overall engine temp.

FUEL LEVEL

Never operate at WOT when the vehicle fuel levels are below a 1/8 tank. Low fuel levels could cause the fuel pump to cavitate and you'll have fuel flow spikes resulting in lean conditions and consequently detonation.

BELT LENGTHS

Changing pulley combinations will require belt changes to minimize belt stretch and tensioner travel. See the following charts for a guide. **NOTE:** Boost is a guide and can vary with environment, engines, combinations.

PULLEY/BELT LENGTH GUIDE		
SC Pulley	Stock Balancer	20% Balancer
4.000"	82.5"	87.0"
3.875"	82.0"	87.0"
3.750"	82.0"	86.4"
3.625"	82.0"	86.4"
3.500"	81.5"	86.4"
3.375"	81.5"	85.4"
3.250"	81.0"	85.4"
3.125"	81.0"	85.4"
3.000"	80.6"	85.2"
2.875"	80.6"	85.2"
2.750"	80.6"	85.2"

PULLEY/BOOST/132MM TB		
SC Pulley	Stock Balancer	20% Balancer
4.000"	10	15
3.875"	11	16
3.750"	12	17
3.625"	13	18
3.500"	14	19
3.375"	15	20
3.250"	16	21
3.125"	17	22
3.000"	18	23
2.875"	19	24
2.750"	20	25

PULLEY/BOOST/STOCK TB		
SC Pulley	Stock Balancer	20% Balancer
4.000"	9	N/A
3.875"	10	N/A
3.750"	11	N/A
3.625"	12	N/A
3.500"	13	N/A
3.375"	N/A	N/A
3.250"	N/A	N/A
3.125"	N/A	N/A
3.000"	N/A	N/A
2.875"	N/A	N/A
2.750"	N/A	N/A