

MAGNUSON

SUPERCHARGERS

Installation Instructions for:

Radix

Trailblazer SS Supercharger System
2006-2009 6.0L



Step-by-step instructions for installing the best in
supercharger systems.

*** PREMIUM GASOLINE FUEL REQUIRED ***



ATTENTION!
Your MAGNUSON SUPERCHARGER kit
is sensitive to corrosion!
Take care of it by using 50/50
anti-freeze with de-ionized water.

Magnuson Products LLC
1990 Knoll Drive, Bldg A, Ventura, CA. 93003
(805) 289-0044 * (805) 677-4897 fax
magnusonproducts.com * magnacharger.com

INSTALLATION MANUAL

Magnuson SuperCharger Kit
Radix Intercooled Supercharger System
GM 6.0 liter engines

We encourage you to read this manual thoroughly before you begin work, for a few reasons:
A quick parts check to make certain your kit is complete (see shipper parts list in this manual). If you discover shipping damage or shortage, please call our office immediately.















Take a look at exactly what you are going to need in terms of tools, time, and experience.
Review our limited warranty with care.

Before installing your supercharger system, make sure that your vehicle has *ONLY 91 octane or higher fuel in the fuel tank.*



Use only premium gasoline fuel, 91 octane or better.

When unpacking the supercharger kit DO NOT lift the supercharger assembly by the black plastic bypass actuator. This is pre-set from the factory and can be altered if used as a lifting point!

Tools Required

-  Safety glasses
-  Metric wrench set
-  1/4" drill bit
-  1/4", 3/8", & 1/2" drive metric socket set (standard and deep)
-  8mm hex (Allen) wrench
-  3/8" and 1/2" drive, foot pound and inch pound torque wrenches
-  Belt tensioner wrench or 1/2" breaker bar
-  7/32" socket
-  Drill and 5/16" drill bit
-  Phillips and flat head screwdrivers
-  Fuel quick disconnect tools (included in kit)
-  E5 internal Torx socket
-  Small or angled 3/8" drill motor
-  Drain pan
-  Compressed air

Helpful tools:

-  Pulley wrench (for removal of fan)
-  Torque angle Meter

Important

Our Magnuson SuperCharger kits are designed for stock engines, with stock components, in good mechanical condition only. Installation on worn or damaged engines is not recommended and may result in engine failure, for which we naturally can't be responsible. Magnuson Products LLC is not responsible for the engine or consequential damages.

Magnuson Products supercharger kits are designed for use on stock vehicles. To that end, the alteration or modification of the fuel system, drive train, engine, and/or supercharger outside of stock parameters in any way can result in engine damage or failure for which Magnuson Products is NOT responsible and will void Magnuson Products warranty. Aftermarket engine recalibration devices that modify fuel and spark curve (including, but not limited to programmers) are not recommended and may cause engine damage or failure. Use of non-Magnuson Products approved programming will void all warranties. If you have any questions, call us.



Caution: Relieve the fuel system pressure before servicing fuel system components in order to reduce the risk of fire and personal injury. After relieving the system pressure, a small amount of fuel may be released when servicing the fuel lines or connections. In order to reduce the risk of personal injury, cover the regulator and fuel line fittings with a shop towel before disconnecting. This will catch any fuel that may leak out. Place the towel in an approved container when the job is complete, and of course, no smoking.

Magnuson Products strongly recommends the following:

- Clean your engine compartment before starting any engine disassembly.
- You must have a clean fuel filter - check and replace as needed before installation.
- You must have a clean air filter - replace every 10,000 miles.
- OE type / Stock spark plugs and stock plug gap is recommended.
- **Start with and use only 91 octane gasoline fuel or higher.**

After you finish your installation and road test your vehicle, please fill out and mail the limited warranty card, so we can add you to our files (this is important for your protection).



Please remember to follow all safety rules that apply when working, including:



Wear eye protection at all times.



Do not work on a hot engine.

Be careful around fuel - use shop towels to catch any spills and dispose of towels properly.



1. With an 8mm wrench disconnect the negative (-) battery cable and wrap the terminal end with electrical tape. Ensure that the cable is far enough away from the battery, that it does not accidentally touch the battery and make contact during the installation.



2. Once the battery is disconnected go ahead and remove the ECM (Engine Control Module) and the TCM (Transmission Control Module). Both modules are located on the drivers' side, just below the fuse box and in front of the fan assembly. **NOTE: If your vehicle comes with the optional 6-speed automatic transmission, the TCM is located inside the transmission and should NOT be removed and sent in for programming. In this instance, disregard further mention of the TCM and send in only the ECM.**



3. Disconnect the electrical plug from the modules. First release the orange locking tab (tab is only on the ECM plugs, not the TCM), and then move the connector release arm forward to release the plug.



4. Disconnect all three plugs; there are two on the PCM and one on the TCM.

5. Remove both modules from the vehicle.



6. Here are the two modules; they need to be sent to Magnuson Products for calibration.

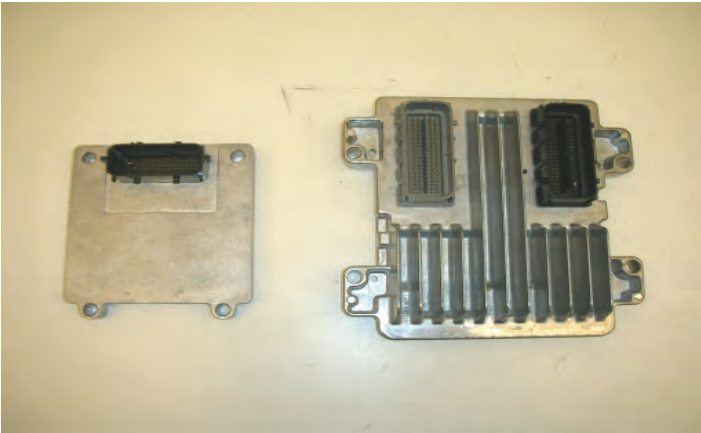

7. Here are the shipping materials supplied to quickly return the vehicle computers to Magnuson Products LLC.



8. Completely fill out the pre-paid shipping form supplied and then remove the adhesive label on the third page, placing it on the top of the box. Take the box to your nearest UPS office to be returned to Magnuson Products LLC. Magnuson will then re-program the computer and quickly return it to you via UPS.



9. Relieve the pressure in the fuel tank by removing the fuel filler cap.



10. On the right (passenger) side of the intake manifold, locate the fuel pressure test port. **CAUTION! The fuel in the system is under pressure! Relieve the pressure in the fuel system by depressing the check valve with a screwdriver and collecting the fuel with a shop towel. Magnuson Products strongly recommends the use of safety goggles.**



11. When the engine is cool, remove the radiator reservoir cap. **Do not remove the cap if the engine is still hot or serious injury may result.**



12. Remove the engine cover wing bolt fasteners.



13. Remove the engine cover completely, as it will not be reused.



14. Loosen the air tube clamp with a 8mm nut driver.



15. Loosen the Mass Air Flow meter (MAF) clamp with a 8mm nut driver.

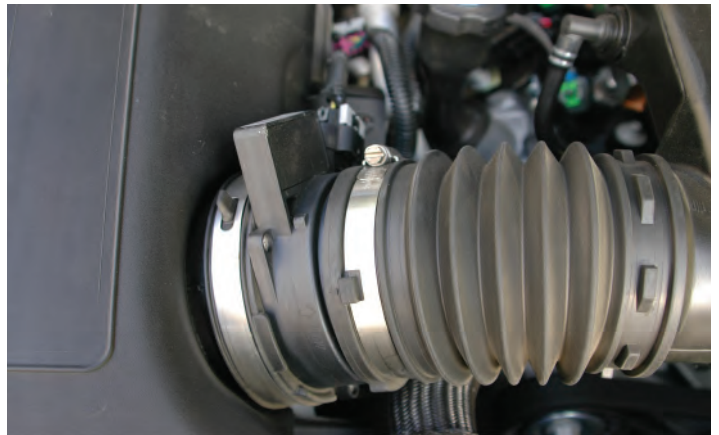

16. Remove the PCV vent pipe from the front, top barb of the passenger (right) side valve cover.



17. Remove the Air tube complete with the PCV vent pipe from the vehicle. It will not be re-used.



18. Unplug the Mass Air Flow meter (MAF) connector by pulling up on the gray release trigger and the squeezing the connector.



19. Disconnect the eight fuel injector connections by gently pulling up on the gray (or green, depending on model year) plastic release trigger on the connector and then pulling firmly on the connector itself. Disconnect the coil pack connector and then the four wire harness clips that secure the harness to the right side of the engine.

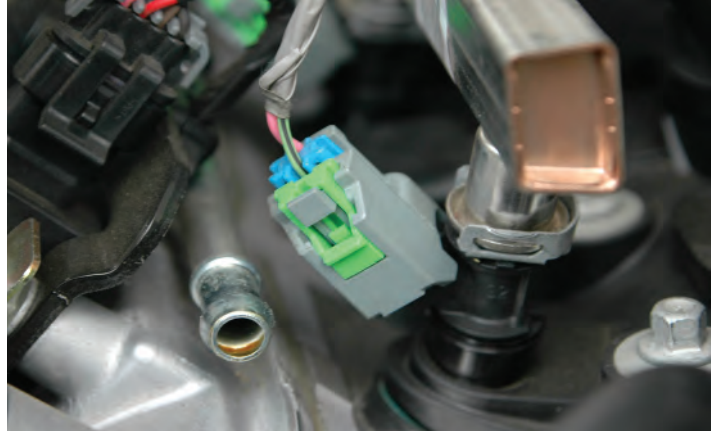

20. Disconnect Electric Throttle Control (ETC) connector from the throttle body by removing the gray plastic locking tab first, then squeeze and pull free the ETC connector itself.



21. Disconnect Manifold Absolute Pressure (MAP) connector from the sensor on the top of the intake manifold and pull the connector free.



22. Disconnect the evaporative purge solenoid EVAP connector located on the top of the driver (left) side fuel rail, by raising the black plastic retaining clip and then pull free the connector itself.



23. Disconnect the Air Conditioning (A/C) pressure connector from the pressure switch and from the clip on the cylinder head.



24. **THIS STEP IS IMPORTANT! Cover the Air Conditioning (A/C) pressure switch with masking tape to protect it during the supercharger installation process.**



25. Disconnect the EVAP vent tube from the solenoid by squeezing the retainer, then release the tube from the solenoid located on the top of the fuel rail on the driver (left) side. Follow the same procedure on the other end of the vent tube at the firewall and remove the tube from the vehicle.



26. Remove the Positive Crankcase Vacuum (PCV) hose from the barb at the rear of the valve cover on driver side.



27. Remove the power brake hose and check valve from the brake booster.



28. With the fuel line disconnect tool supplied, remove the fuel lines from the fuel rail. For best results with the tool, first push the fitting onto the hard-line barb, then insert the tool and press it into the fuel line, then pull the fuel line from the hard-line barb. **Caution! The system may be under pressure. Avoid open flame or other sources of ignition.**



29. Using a 8mm socket wrench remove the ten intake manifold bolts.



30. Carefully remove the intake manifold assembly and set aside.



31. Using a vacuum cleaner, remove any dirt or debris from the intake port area. **(Be careful not to get any dirt in the intake ports.)**



32. Cover the intake ports with tape or clean rags to keep dirt and objects from entering the engine. **(Remember, be clean.)**



33. As it will be necessary to drain the cooling system and most SS trucks have no drain on the radiator, loosen the two bolts that secure the thermostat assembly with a 10mm socket wrench. Catch the coolant in a drain pan for reuse. Retighten the thermostat bolts after draining is complete.

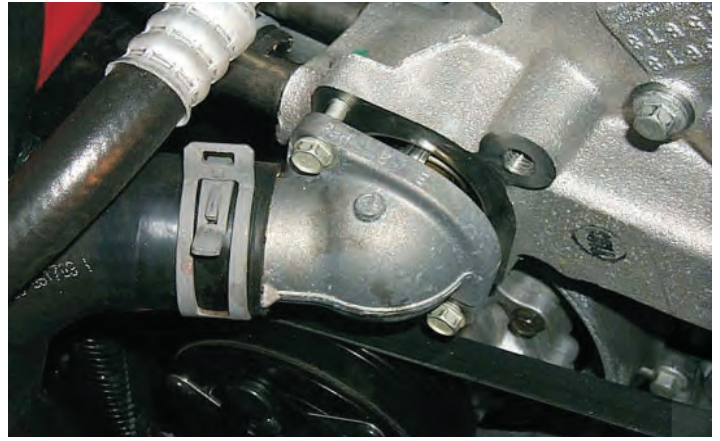

34. Remove the steam vent hose from the steam pipe by squeezing the clamp with a pair of pliers and pulling the hose free.

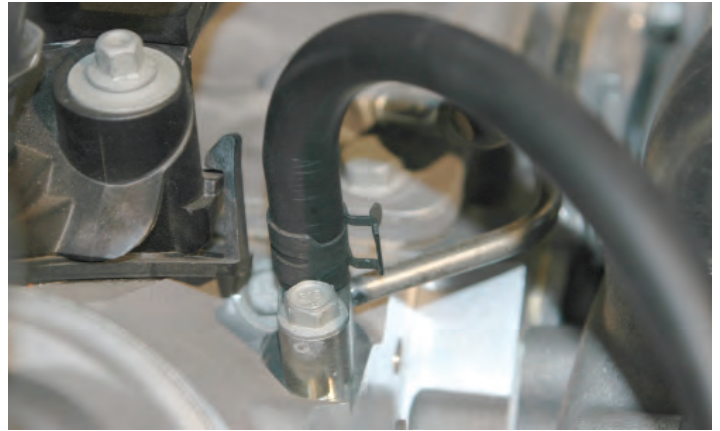

35. Using a 10mm socket wrench remove the two coolant vent pipe bolts.

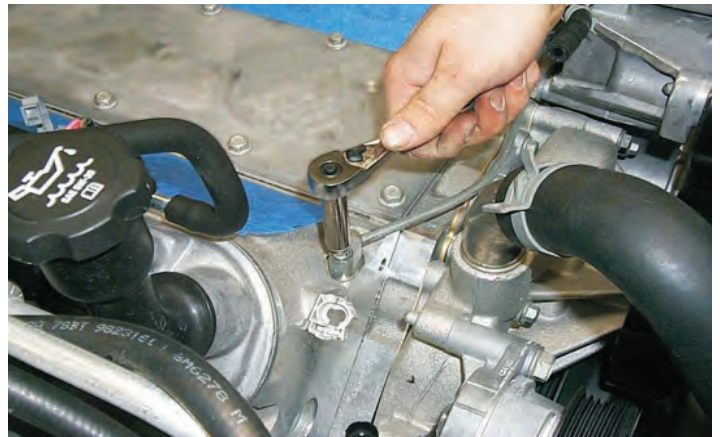

36. Remove the vent pipe assembly. **(Make sure that the O-ring gaskets did not stick to the cylinder heads, if so remove them.)**



37. Using a 15mm tensioner wrench or breaker bar, remove the stock serpentine belt from the vehicle. The belt will not be reused.

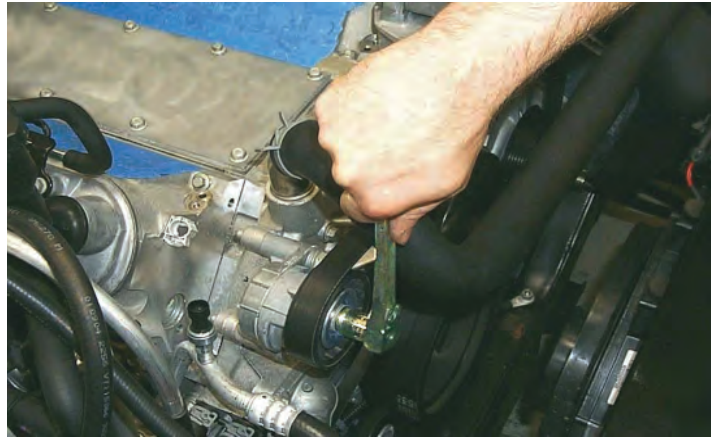

38. Using a 15mm socket wrench remove the three bolts holding the factory belt tensioner to the bracket and remove the tensioner. Bolts will be used in a later step.



39. Disconnect the positive (+) battery cable from the back of the alternator with a 10mm wrench. Disconnect the Alternator control plug at this time as well.



40. Use a 15mm socket wrench to remove the two bolts holding the alternator to the alternator bracket and then remove the alternator.



41. It will be necessary to make clearance on the alternator mount casting for the new manifold to fit properly. The new manifold should not touch the alternator mount. These modifications can be easily done with the mount in place.

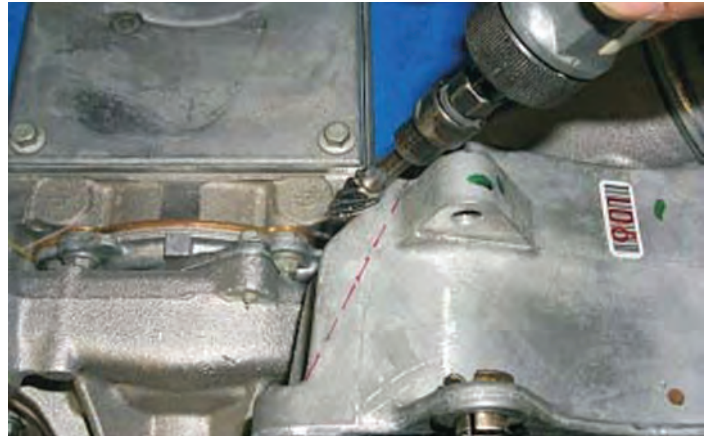

42. For clarity this mount is shown removed from the engine. Using a marking pen and a straight edge, mark a line as shown on the top surface of the alternator mount. Start the line at the drivers (left) rear corner of the idler mount and then to the right rear corner of the alternator mount. Continue the line at an angle for a distance of about 1-1/4" to the back edge of the casting behind the alternator mount. Using a suitable grinder and eye protection, remove the material up to the line.



43. On the back surface of the alternator mount, remove the shaded area as shown.



44. Here is what your finished alternator mount should look like.



45. Install the new O-ring gaskets onto the coolant vent pipe bases using some of the lubricant supplied.



46. Using the stock bolts previously removed, install the new coolant vent pipe supplied. Ensure that the O-ring gaskets are installed correctly. Torque the bolts with a torque wrench and 10mm socket to 106 lb-in. **Verify your torque wrench settings.**

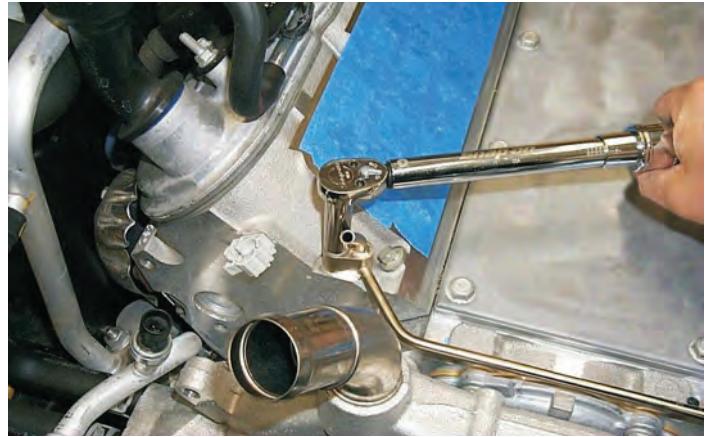

47. Using the supplied 3/8" hose, connect a 14" length to the PCV valve as shown on the driver side valve cover. Lay the other end of the hose off to the driver side, out of the way. (To be connected in a later step.)



48. If your connector has one, remove the rubber cover and then unplug the electrical connector from the Oil Pressure Transmitter.



49. Remove the Oil Pressure Transmitter with a 27mm (1-1/16") socket wrench.



50. Remove the engine valley cover and gasket by removing the eleven bolts with a ratchet and 13mm socket.



51. The gasket will be re-used, the original valley cover and bolts will not. Inspect the gasket for any damage and then reinstall. **Note: It will only fit correctly in one position.**



52. Using a small straight blade screwdriver, remove the 8 O-rings from the underside of the engine valley cover and transfer them to the grooves in the bottom of the new cover.

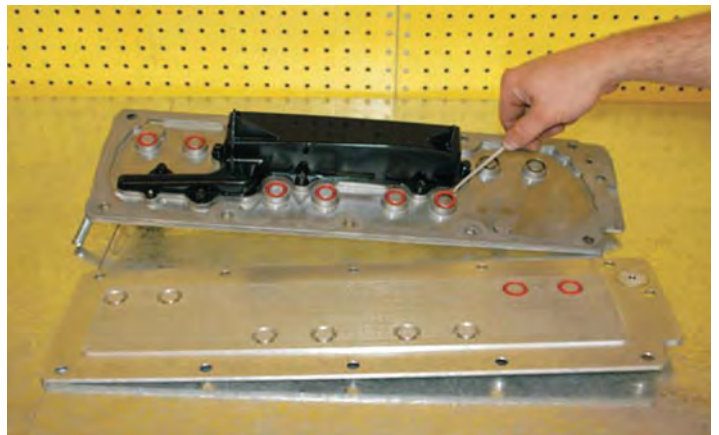

53. Install the new engine valley cover and flathead bolts supplied with a 5mm Allen socket and torque the bolts to 18 lb-ft. Verify your torque wrench settings. Insert the six new O-rings supplied in kit in the recesses in the new valley cover.



54. Install the Oil Pressure Transmitter in the new valley cover with a 27mm (1-1/16") socket and torque it to 15 lb-ft. **Verify your torque wrench settings.**



55. If your vehicle comes with this stud-nut mount by your valley cover, cut the stud off flush with the top of the nut, or replace the stud with a bolt. (For a closer view of the stud-nut explained above, please look at the next step/image.) **This is extremely important, if not followed the intake manifold will have a huge vacuum leak.**

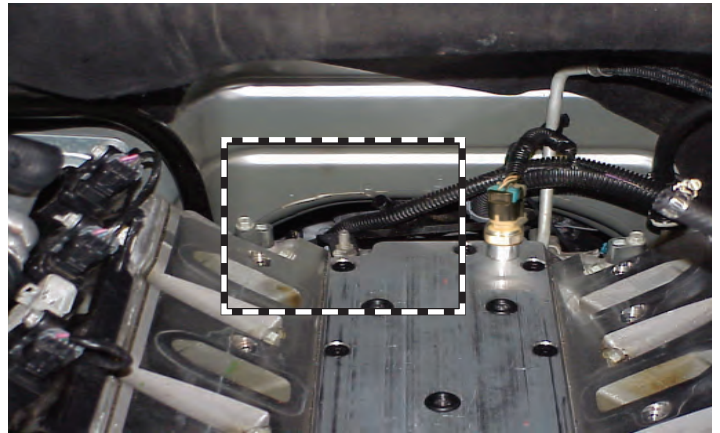

56. This close-up image points to the possible stud-nut location by the valley cover.

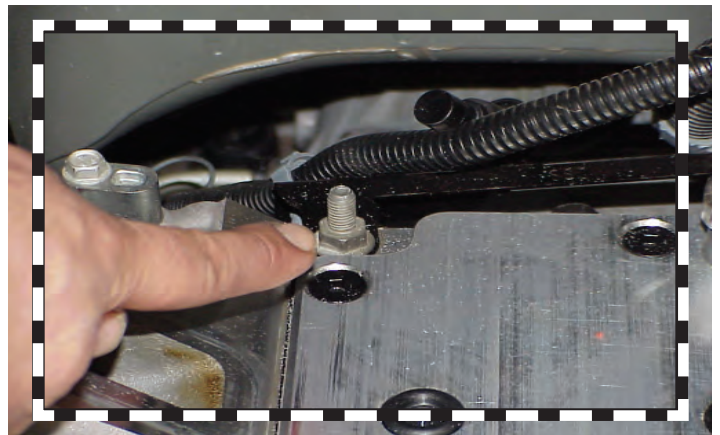

57. Re-connect the oil pressure transmitter electrical connector.

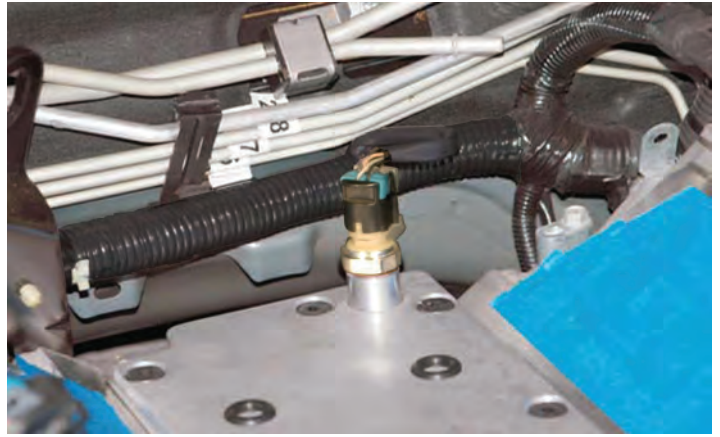

58. Remove the steel bracket on the rear of the left cylinder head with a 15mm wrench. The bracket will not be re-used.



59. On each side of the engine, disconnect the main coil bracket plug.

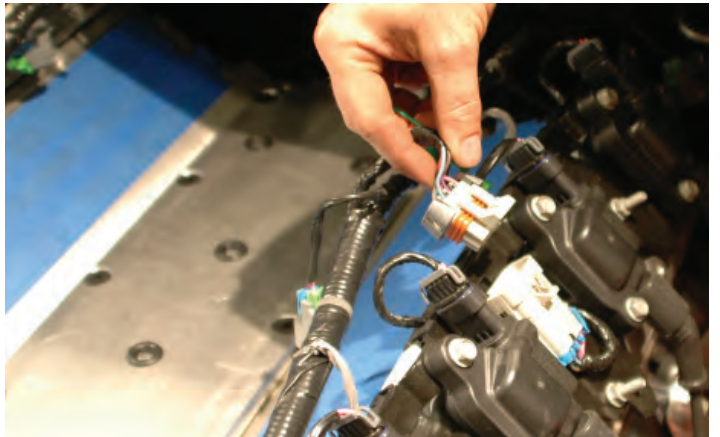

60. Disconnect all eight plug wires from the coil packs.



61. Use a 10mm wrench to remove the bolts holding the coil packs to the valve covers.



62. Remove both coil brackets from the engine compartment.

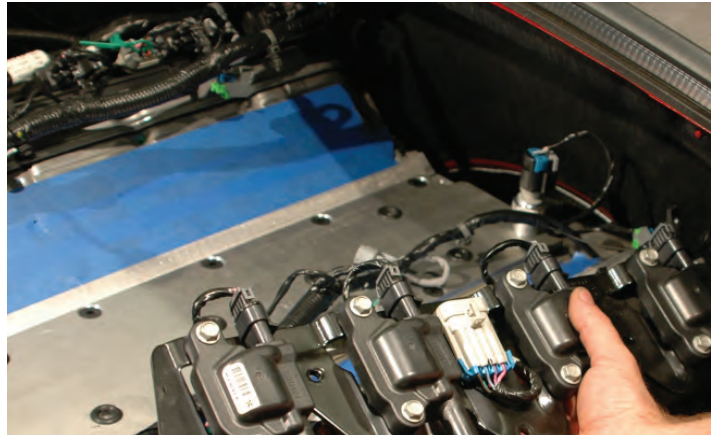

63. The coil packs will need to be modified to accommodate the new supercharger system. Use a small screwdriver to unclip the top and bottom halves of the plastic wire covers. Remove these covers from the coil packs completely.



64. Remount the coil packs to the valve cover using a 10mm wrench.



65. Replace the plug wires on the coil packs on both sides of the engine.

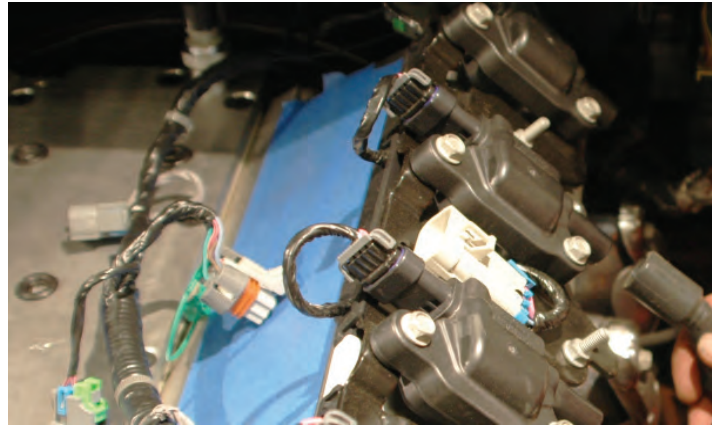

66. Reconnect the main coil plug on both sides of the engine.

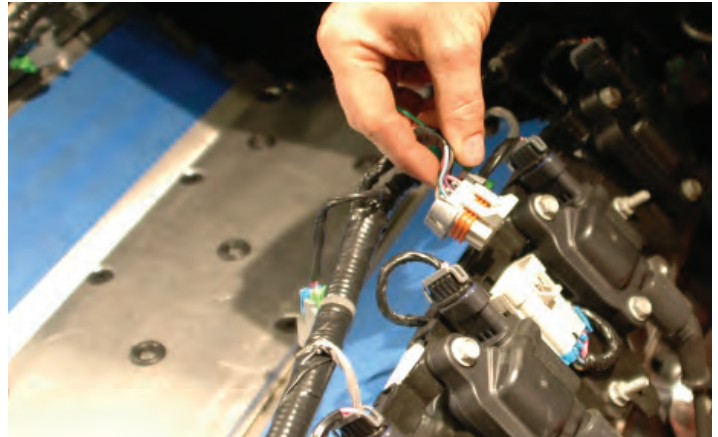

67. Remove the upper radiator hose at the upper water pump outlet.



68. The fan and fan shroud need to be removed for access to the crank pulley. Use a belt wrench to wrap around the water pump pulley to anchor it for removing the fan.

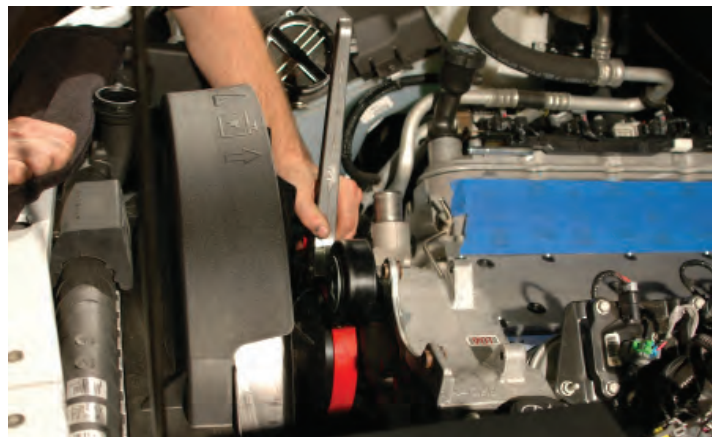

69. Use a large wrench to loosen the fan-clutch mounting nut.

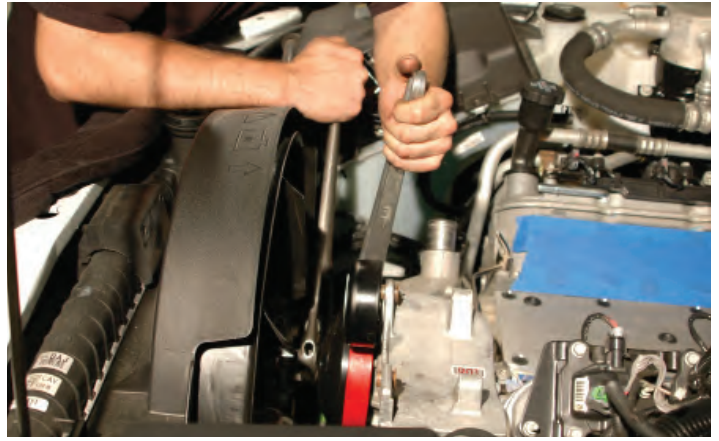

70. Unscrew the fan nut from the water pump shaft.

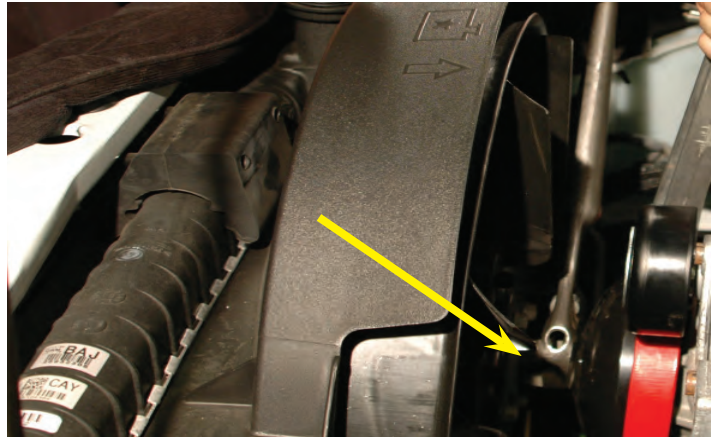

71. Use a 10mm wrench to remove the two bolts holding the fan shroud to the radiator, these are on the top, one on each side.

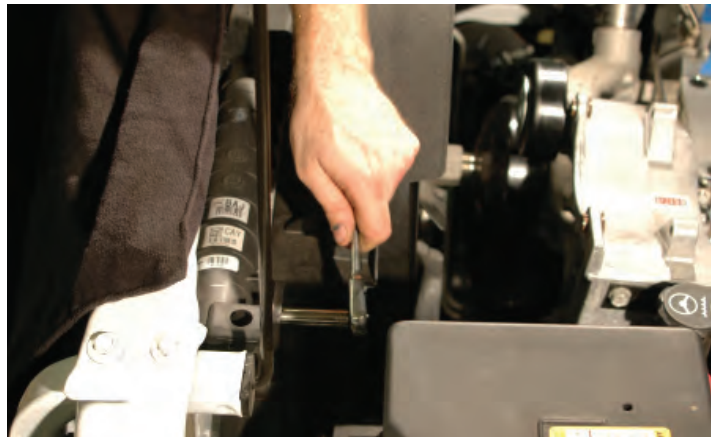

72. On the bottom of the fan shroud on each side is a fabric deflector. Pull the deflector off the mounting pins on the fan shroud.



73. On the passenger side, forward of the air box is a hard plastic deflector. Pull the push-rivet out as shown and lift the deflector out of the vehicle.



74. Carefully pull the fan shroud and fan together out of the engine compartment.

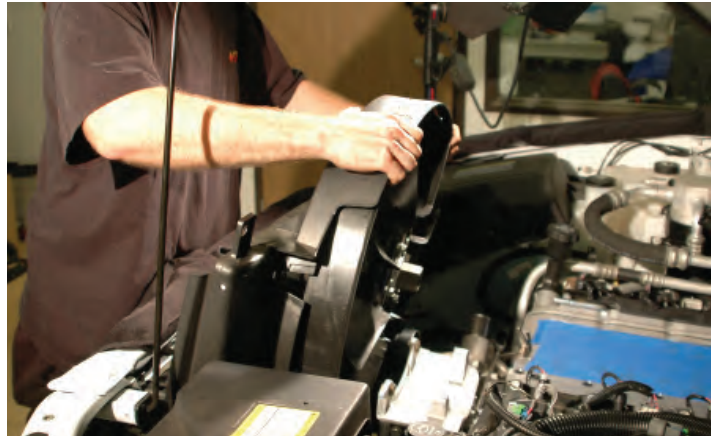

75. Use a 15/16 (24mm) impact wrench to remove the factory crank bolt from the crank pulley. You may need to heat the pulley around the bolt. Be extremely careful when using flame in and around the engine compartment.



76. Install the provided drill guide using the provided temporary crank bolt.



77. Torque the temporary bolt to 35 ft lbs. **Verify your torque wrench settings.**

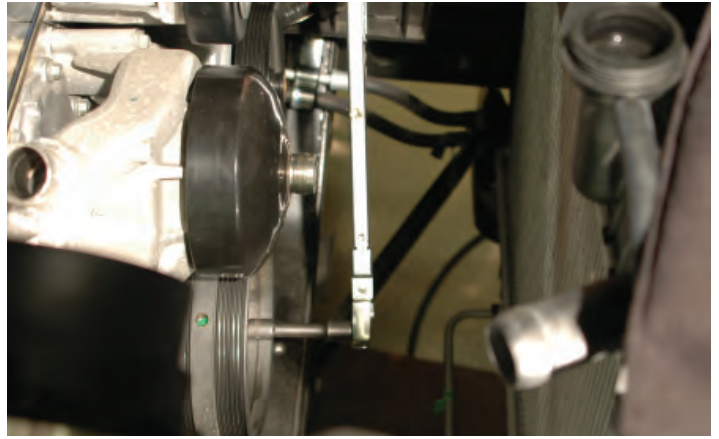

78. Use the provided drill bit, a small angled drill, and the drill guide to drill two holes to tie the crank and pulley together. Drill all the way to the second step in the bit for both holes.



79. Use compressed air to blow out the two holes. Make sure you are wearing eye protection, and that no openings to the engine are contaminated with the metal shavings.



80. Use the provided reaming bit to clean out the two holes.



81. Once again. Use compressed air to blow out the two holes. Make sure you are wearing eye protection, and that no openings to the engine are contaminated with the metal shavings. Use an impact wrench and 15/16" (24mm) socket to remove the temporary Crank bolt and drill guide.



82. Coat the two pins provided with green Loc-tite 680, and push them into the two holes you just prepared.

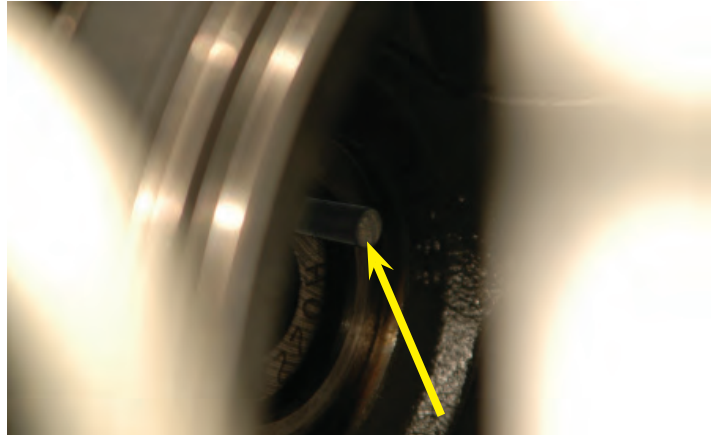

83. Tap the pins in using a hammer and punch. Make sure they are seated in far enough so as to not touch the crank bolt being installed next.



84. Install the provided new harmonic damper crank bolt and torque to General Motors specifications of 50 N-M (37 ft lbs) then tighten an additional 140° using a torque angle meter.



85. Replace the fan shroud and fan into the engine compartment.

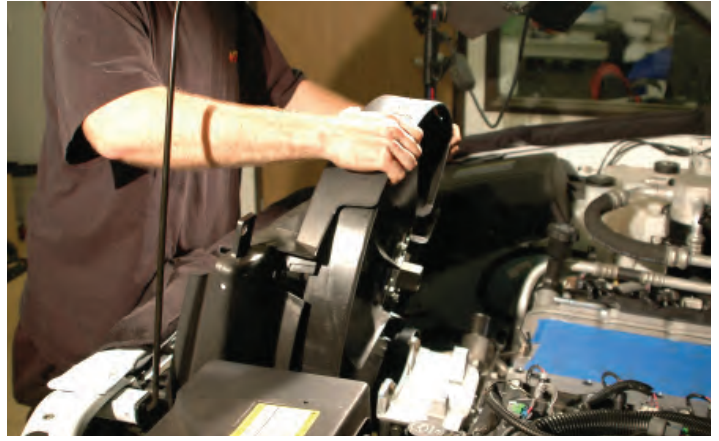

86. Use a 10mm wrench to bolt the fan shroud back to the radiator using the bolts removed earlier.

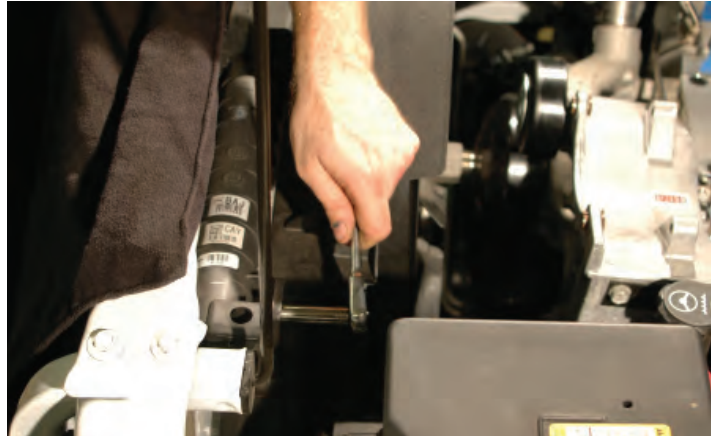

87. Pull the lower fabric deflectors back onto the lower mounting pins.



88. Place the hard plastic deflector back on the passenger side upper mount in front of the air box and secure with the OEM push rivet as shown.



89. Wrap a belt wrench around the water pump pulley.

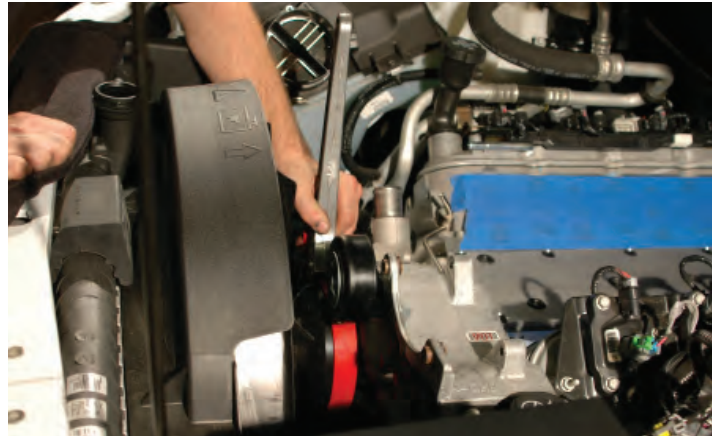

90. Use a large wrench to bolt the fan clutch assembly back onto the water pump.

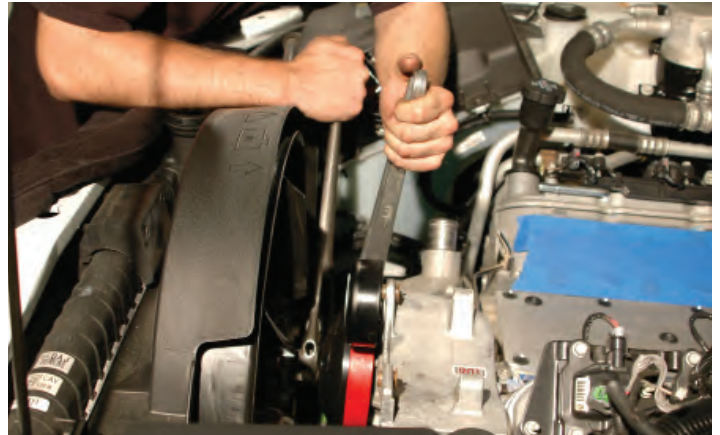

91. Remove the stock Idler pulley from the mounting bracket and set aside for later use.



92. Using a soft hammer, knock the factory bolt loose from the idler pulley. The bolt retainer and stand-off pictured here on the right side of the pulley, will not be re-used. **Note: The bolt, dust cover and idler will mount to new tensioner bracket.**



93. The existing Alternator bracket will have to be modified for clearance with the new Tensioner bracket. Make sure that all openings are covered, using a file, die-grinder or suitable sanding disc, remove enough material for clearance with the new bracket.



94. Here are the new components for the tensioner assembly.

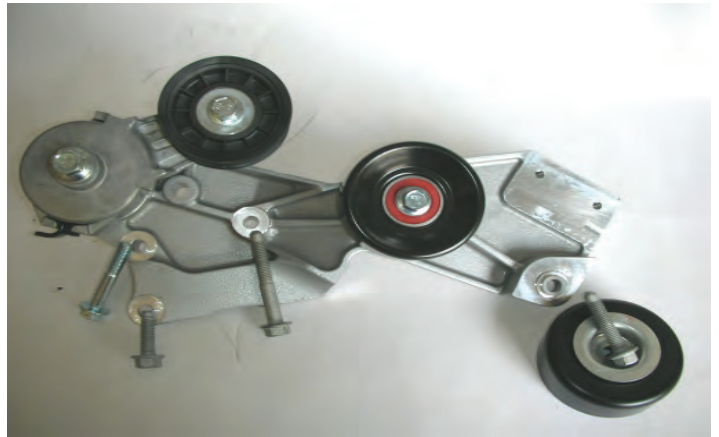

95. In the original tensioner location, mount the new tensioner assembly. Use one long factory bolt and one short factory bolt and the hardware provided.

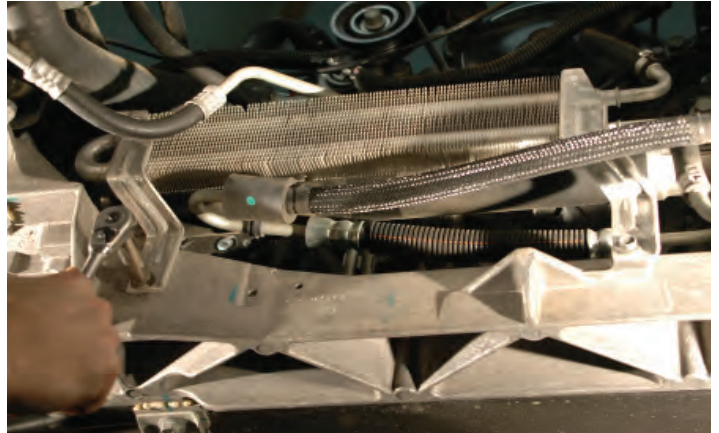

96. Torque all the bolts to 40ft-lbs with a 15mm socket wrench. **Verify your torque wrench settings.**

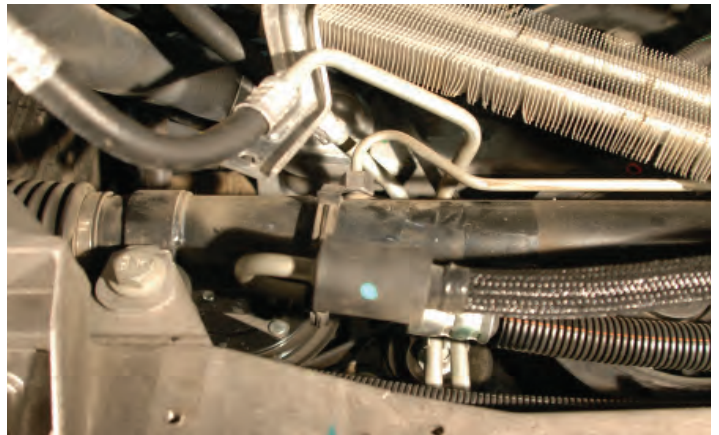

97. Reinstall the upper radiator hose and clamp onto the stock water pump outlet.



98. Remove the stock MAP sensor by removing the retaining clip with a screwdriver and then gently pulling up the sensor. Be careful not to damage the O-ring seal. **NOTE: On 2009 model year this connector may have changed.** To remove, insert a small screwdriver into the slot opposite the slide-tab lock. Lever the locking tab outward to release the lock, then slide the lock to remove.

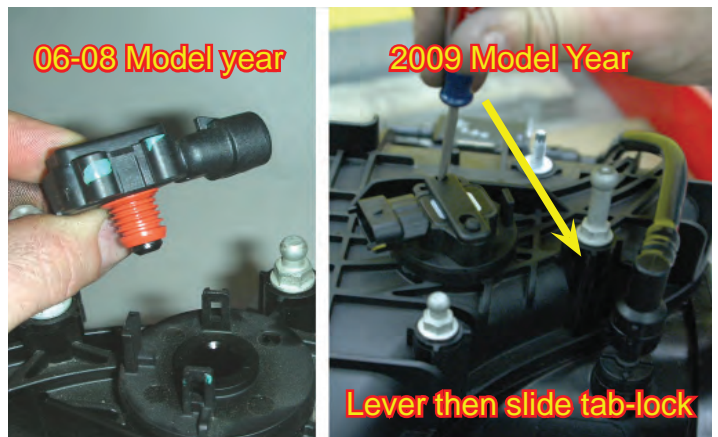

99. For 2009+ MAP Sensor, skip to step 100. If you have the 99-08 style MAP Sensor, you will need to install the provided bushing. **YOU MUST install the bushing with sealant to prevent a vacuum leak.** We recommend black silicone RTV or green Loctite 680. Be sure to wipe off any excess sealant inside the bushing. Allow sealant to cure before starting engine.

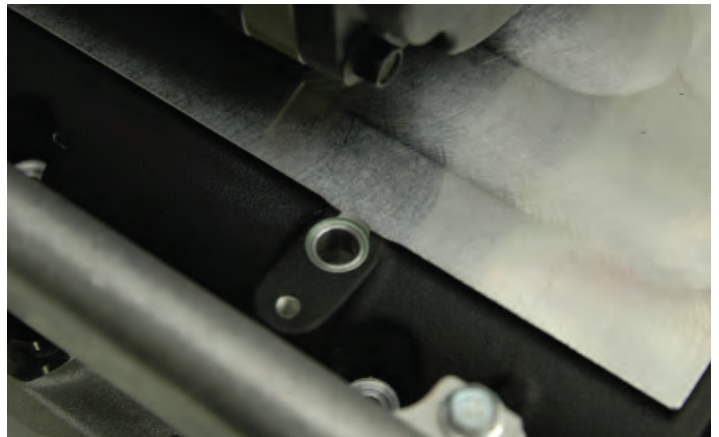

100. Put some lubricant on the MAP sensor seal and press the MAP sensor into the provided hole in the supercharger manifold as shown.



101. Using a 4mm Allen wrench, install the MAP sensor retaining clip with the provided 6mm button head screw as shown.

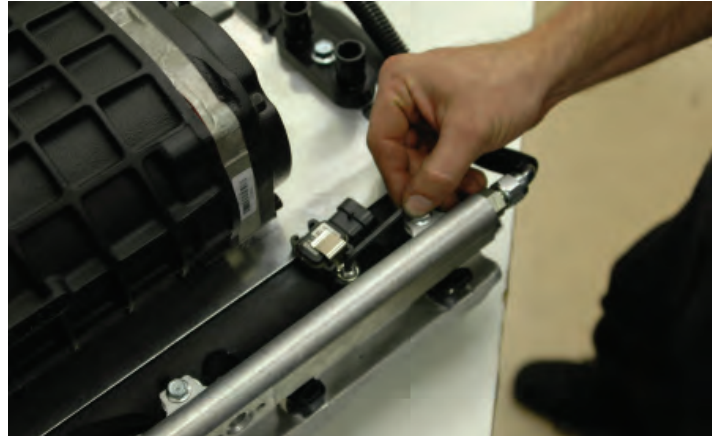

102. Install the intake manifold gaskets supplied into the recesses on the supercharger manifold face. Ensure that the gaskets are fully seated.



103. Assemble the solenoid bracket and bolts onto the fuel manifold.

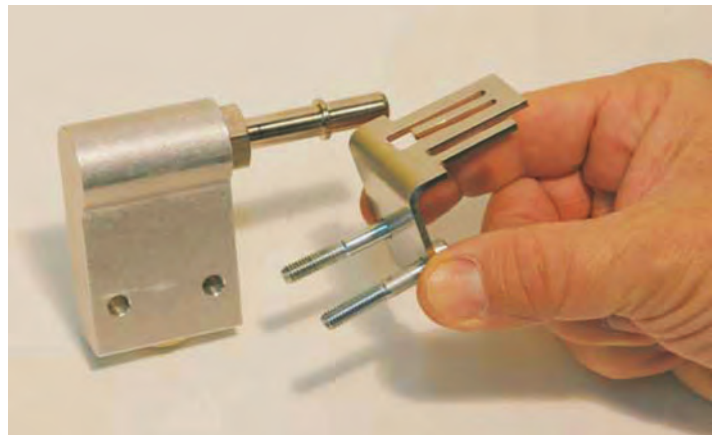

104. Using some of the lubricant supplied, install the O-ring into the recess on the fuel rail. Install the fuel manifold and bracket onto the fuel rail. **Take care not to pinch the O-ring.**



105. Torque the fuel manifold bolts to 106 in-lbs using a 10mm socket and torque wrench. **Verify your torque wrench settings.**



106. Using a 10mm socket wrench remove the stock throttle body from the stock intake manifold.



107. Next, using a #5 internal Torx socket remove the mounting studs from the stock intake manifold.



108. Remove the throttle body O-ring from the intake manifold.



109. Install the throttle body O-ring into the inlet manifold groove on the supercharger assembly.

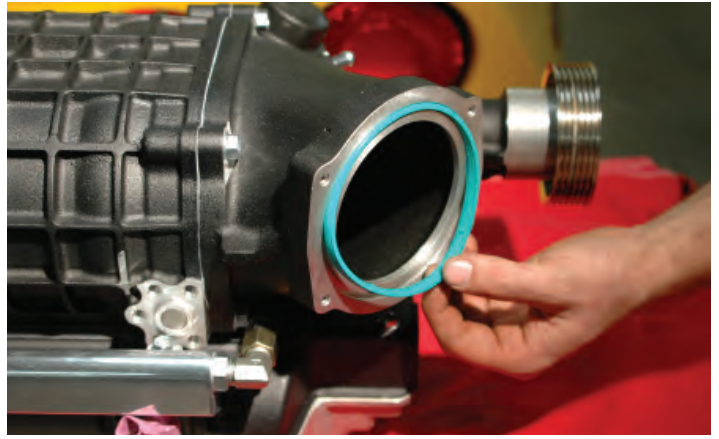

110. Install the studs removed in the step # 107 into the new supercharger inlet manifold using a #5 internal Torx socket and wrench (lightly tighten).

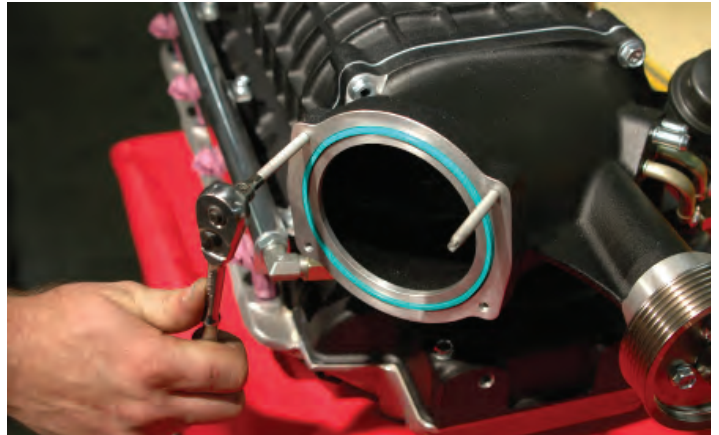

111. Connect the Throttle Body removed from the stock manifold in step # 106 to the new supercharger intake using a 10mm socket wrench. Torque the fasteners to 106 in-lbs. **Verify your torque wrench settings.**



112. Remove tape from the cylinder head port faces and lubricate the surfaces with silicone spray or soapy water. **Do not use any petroleum-based products that could damage the port gaskets.**



113. Using an assistant, carefully lower the supercharger and manifold assembly into place. Ensure that hoses and wires are out of the way. Do not use the black bypass canister to lift the assembly by or damage will result. **Use care not to damage the port gaskets.**



114. Start all ten bolts of the manifold to the cylinder heads by hand to ensure proper alignment of the manifold. Then, torque all ten bolts that secure the manifold to the cylinder heads gradually and evenly to a torque of 106 In-lbs. Use a 10mm socket and torque wrench. **Verify your torque wrench settings.**



115. Push the fuel line connector on to the fuel manifold. Ensure that the fuel line is pushed all the way on. Pull on the connector to check that it is secure, you should not be able to remove the connector unless you use the removal tool. Reinstall the factory supplied retainer clip.



116. Remove the EVAP solenoid from the mounting bracket on the driver side fuel rail by pushing down on the locking tabs before pulling.



117. Install EVAP solenoid onto new bracket installed in steps 103-105.



118. Re-connect the electrical connection to the EVAP Solenoid that was disconnected in step number 22.



119. Locate the vent tube previously removed from the vehicle.



120. Using a sharp knife cut the plastic tube at the ends to free the two EVAP fittings. **Be sure to only cut the hose not the fitting.**



121. Assemble a new EVAP hose using the fittings and a 10" long piece of the 5/16" vapor hose with the #4 hose clamps supplied.



122. Here is an EVAP hose layout showing the configuration of hoses in the following steps.



123. Connect the newly assembled EVAP line to the end of the solenoid with the electrical connection.



124. Place a cap on the lower right side hose barb on the supercharger inlet manifold as shown, this barb will not be used.

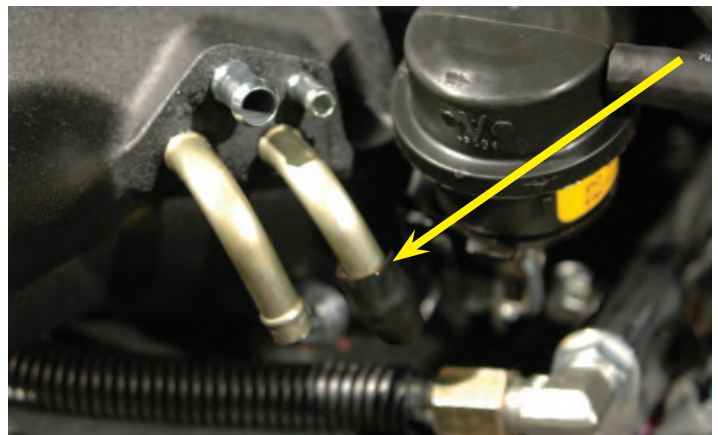

125. Connect the other end of the solenoid to the center barb of the "T" connector using 7" length of the 5/16" Vapor hose and a #4 clamp.

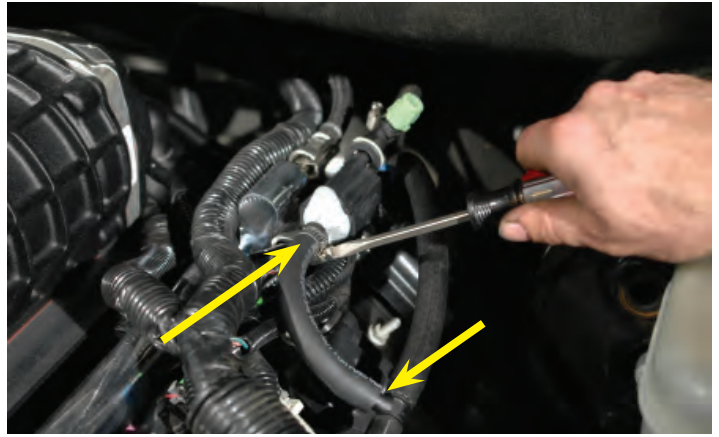

126. At the front of the "T" fitting, connect a 19-1/2" length of 3/8" vapor hose. This hose will form the Positive Crankcase Vent (PCV) line. Connect this other end to the middle barb of the inlet manifold.

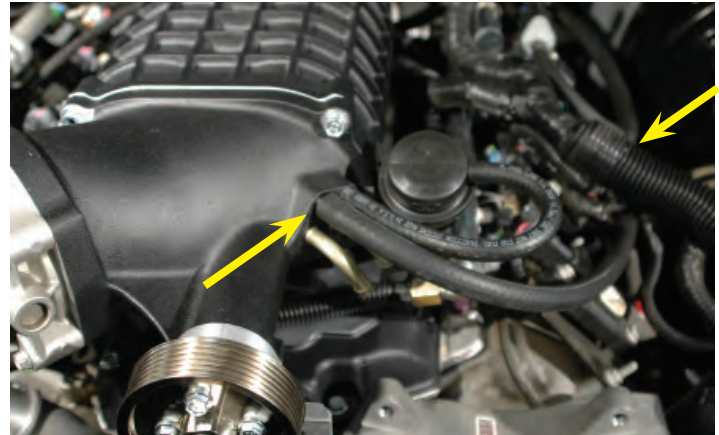

127. To the remaining (rear) barb of the "T" fitting, connect the PCV line installed in step 47 from the rear of the driver (left) side valve cover.

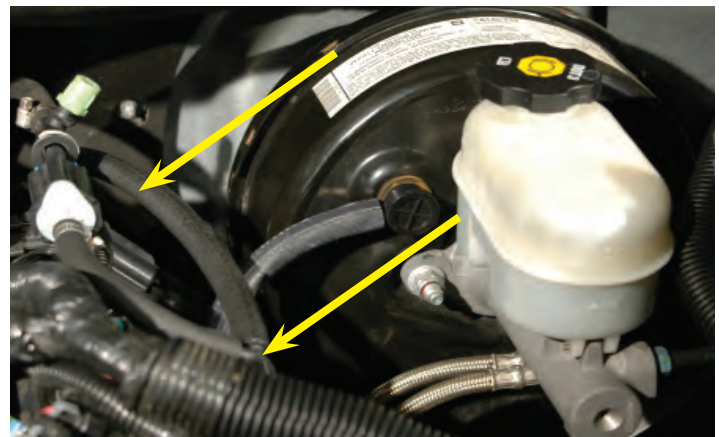

128. Insert the new vacuum check valve into the end of the new 11/32" vacuum hose.



129. Install the new check valve and vacuum hose onto the brake booster.

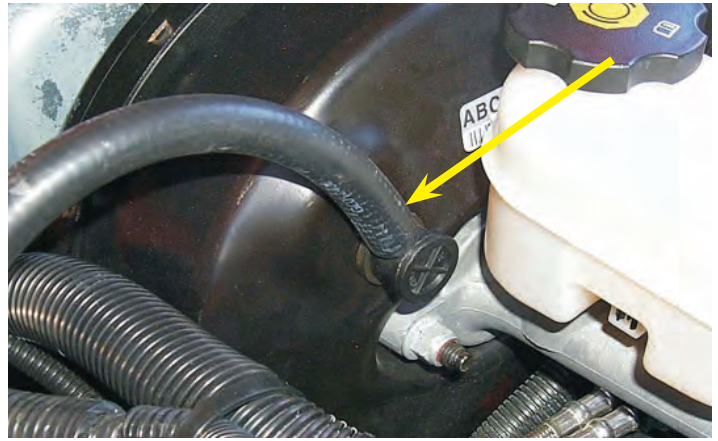

130. Connect the other end of the vacuum hose to the remaining barb on the side of the inlet manifold.



131. Connect the 1/4" steam vent to the barb on the steam pipe. Secure this end with the new #6 clamp supplied.

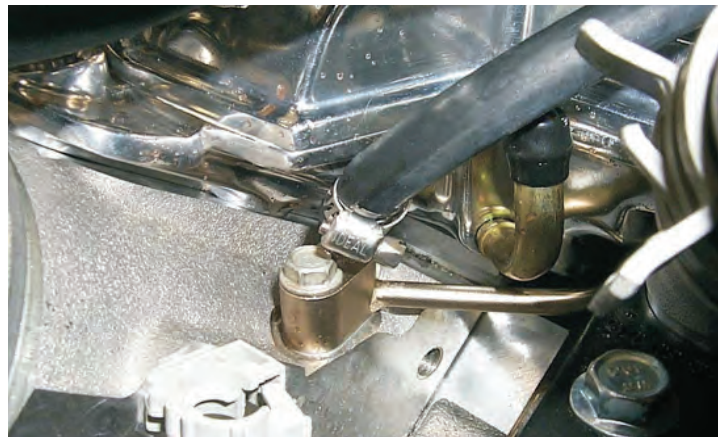

132. Install alternator on the stock bracket and torque the fasteners to 40 ft-lb. Verify your torque wrench settings.



133. Re-attach the battery cable to the alternator terminal and cover it with the rubber boot.

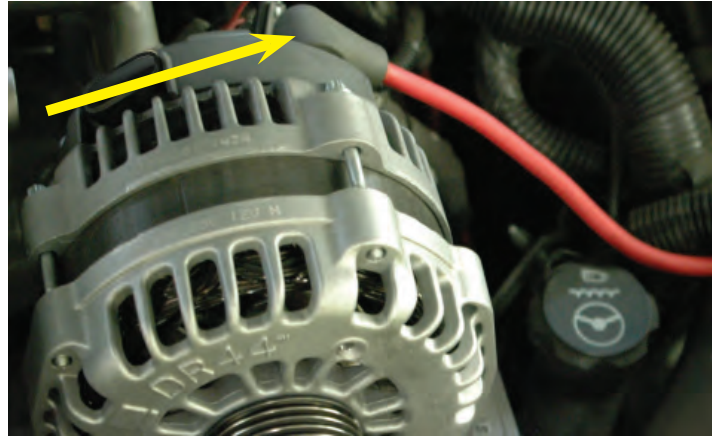

134. Use a 15mm tensioner wrench to compress the tensioner and then install the new drive belt using the diagram shown.

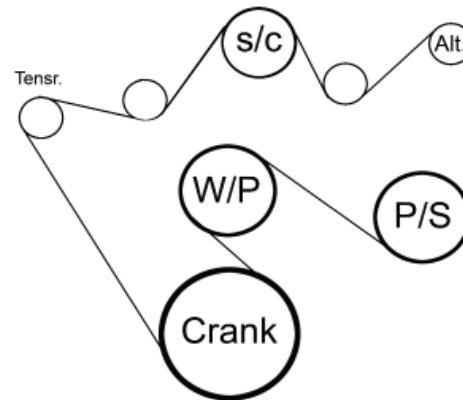

Gates Belt P/N K061098

135. Remove the five fasteners that secure the plastic radiator shroud. Two of the fasteners can be removed with a 7mm wrench. The remaining three are push rivets and can be removed as shown in the following step.

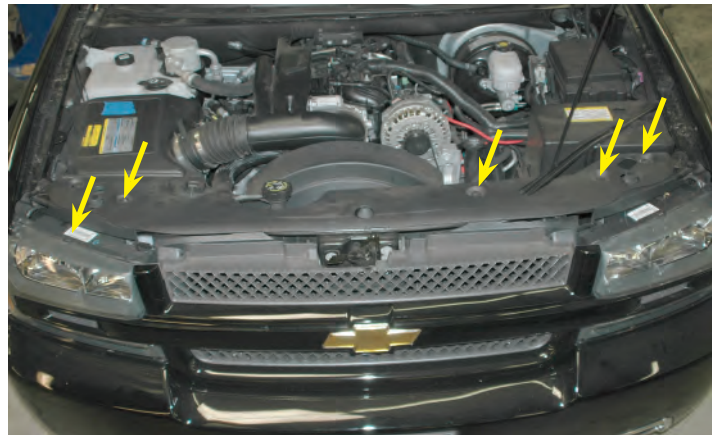

136. Remove the two plastic push-lock rivets from the air filter apron. Do this by gently prying the center of the rivet up with a straight blade screwdriver and then removing the rivets completely.



137. Remove the front grille assembly by CAREFULLY pulling out on it in the locations shown.



138. Remove the grille from the vehicle and set it aside.



139. Remove the headlamp assemblies by pulling up on the release latches in the locations shown. Note: The outer most latch on each side is just under the “eyebrow” of the fender



140. Pull up on the inner headlamp release latch as shown.

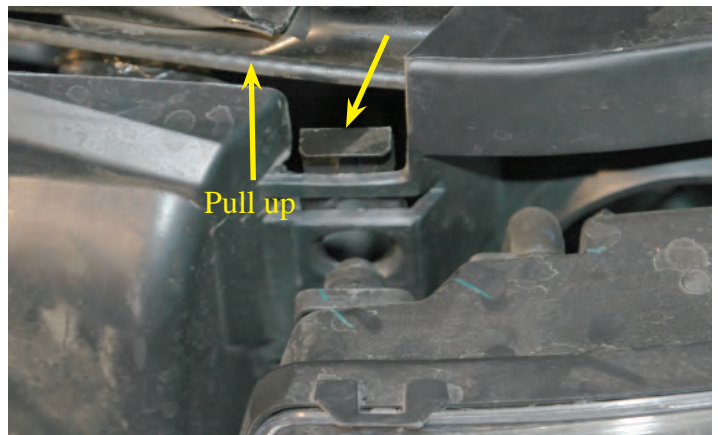

141. Located just under the “eyebrow” of the fender is the outer headlamp release latch. Pull up on the outer release latch with a large flat blade screwdriver.

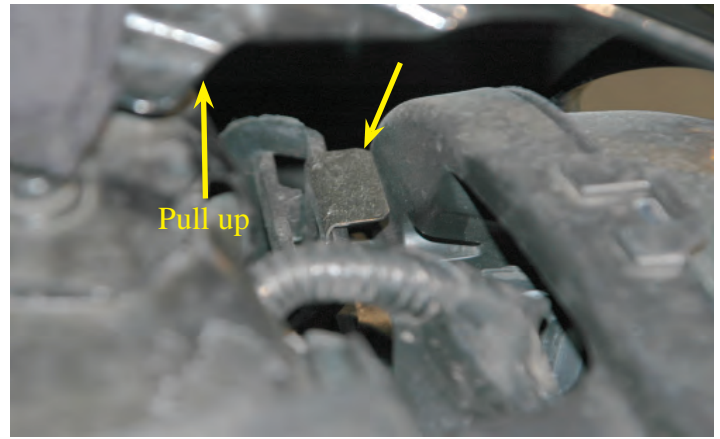

142. Remove the three electrical connections from the back of the headlamp units and then remove the headlamp assemblies.



143. Start to remove the front fascia by removing the ten fascia fasteners with a 10mm socket wrench.



144. Remove the plastic push-lock rivet in the center of the front fascia. Do this by gently prying the center of the rivet up with a straight blade screwdriver and then removing the rivets completely.



145. Remove the four plastic push-lock rivets from the front license plate mount. Do this by gently prying the center of the rivets up with a straight blade screwdriver and then removing the rivets completely.



146. There are four large push rivets that secure the top edge of the air inlet opening in the front fascia. These four rivets have no center "core" like the others, but are difficult to remove. Their locations are shown here from the inside of the front fascia for clarity.

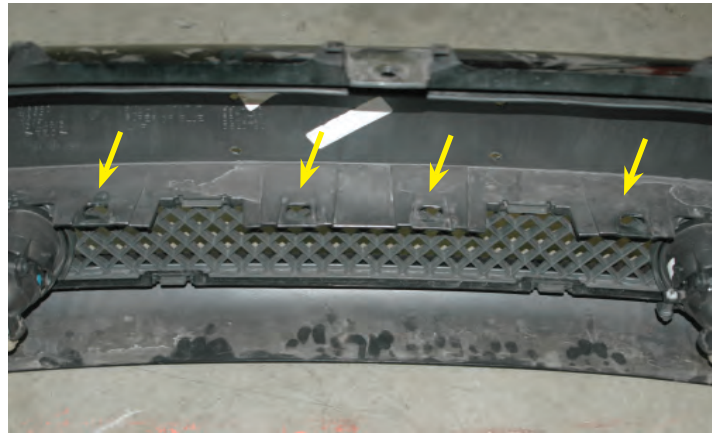

147. To remove the four large push rivets from the top edge of the air inlet opening in the front fascia, pass a large straight blade screwdriver through the grille and pry the rivets free.

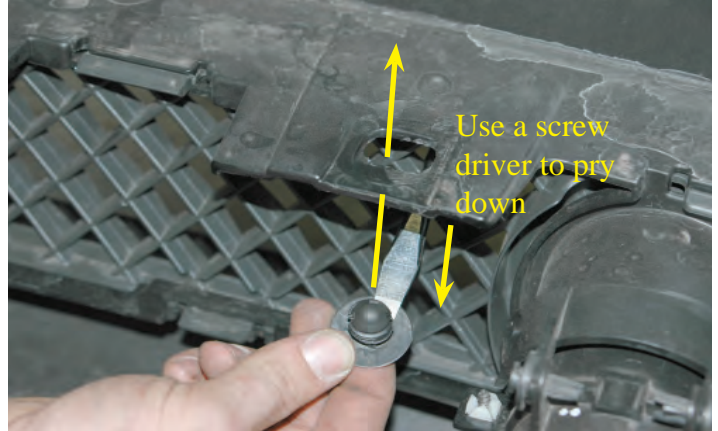

148. Remove the push rivet securing the fascia located at the bottom, front edge of the wheel opening.

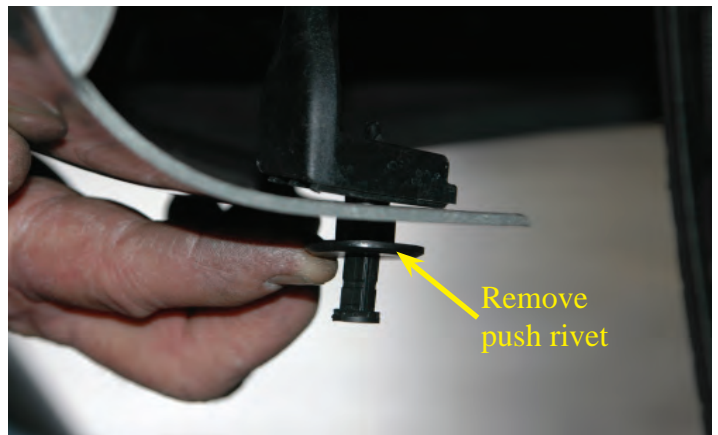

149. At the top edge of the fascia near the headlamp opening, pull firmly to unclip the fascia from the vehicle.

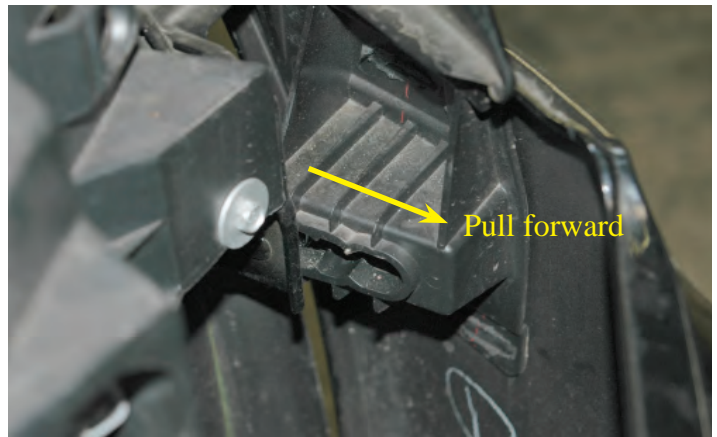

150. Once the fascia is loose, disconnect the two front fog light electrical connectors.



151. Remove the fascia and set it aside.



152. With the front fascia removed, you can now remove the plastic headlight frame from the vehicle.



153. Remove the battery bar that passes over the top of the battery, by removing the three fasteners with a 10mm wrench.

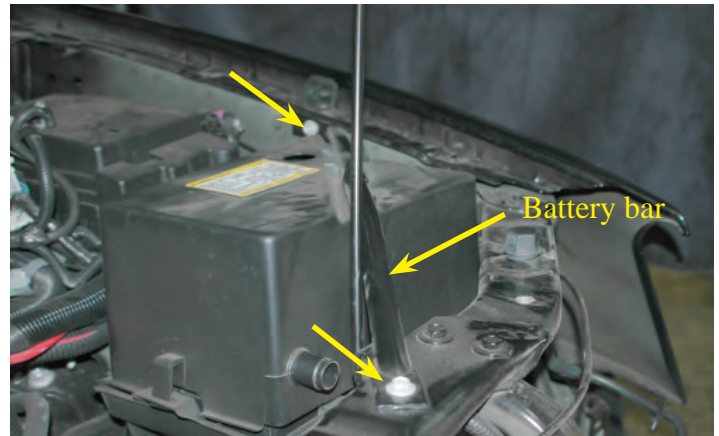

154. Remove the fastener that secures the battery bar strut where it attaches at the bottom of the battery platform with a 10mm wrench.



155. Remove the tubular front cross member that mounts the hood latch assembly. Remove the four fasteners and spacers that secure it with a 13mm wrench.



156. The lower "legs" of the cross member are secured by a single bolt in the middle at the bottom. Remove this bolt with a 12mm wrench. This bolt will be replaced with a provided shorter bolt at re-installation.

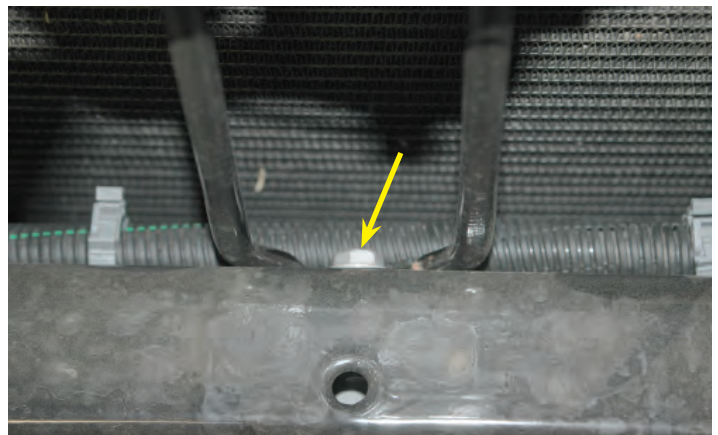

157. Remove the cross member and latch assembly. Note: The hood release cable is still attached! Place the cross member on the left (driver) side of the vehicle with the cable intact.

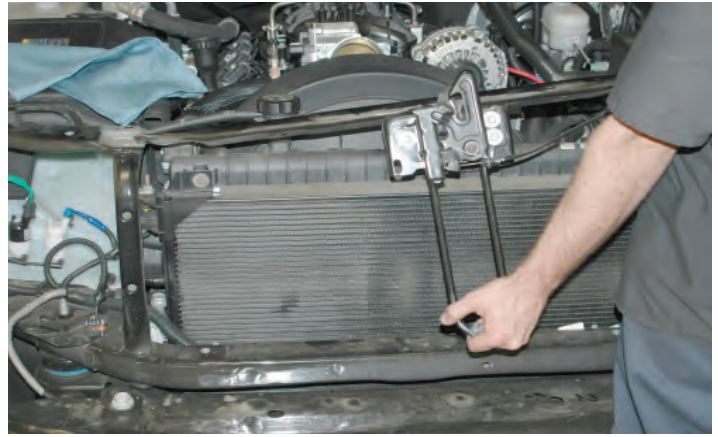

158. Locate the four gray clips that secure the wiring harness to the back edge of the lower cross member.

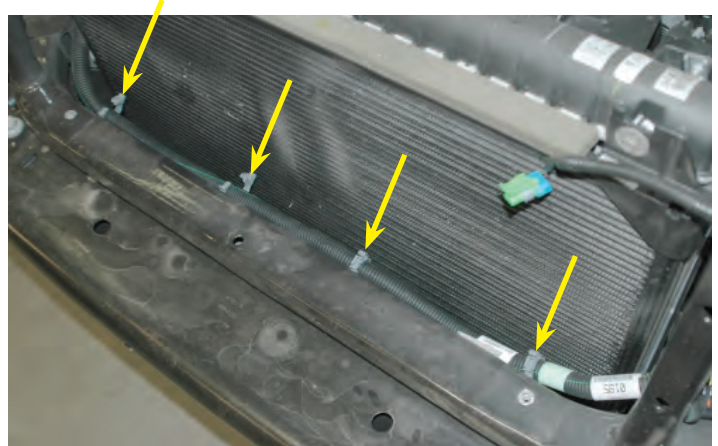

159. Use a small straight blade screw driver to open the clips to free the harness, then remove the four clips from the cross member. Allow the wiring harness to hang down and secure it with the tie straps supplied to the wiring harness directly below the cross member.



160. Remove the two upper bolts that secure the A/C condenser to the radiator with a 10mm wrench.

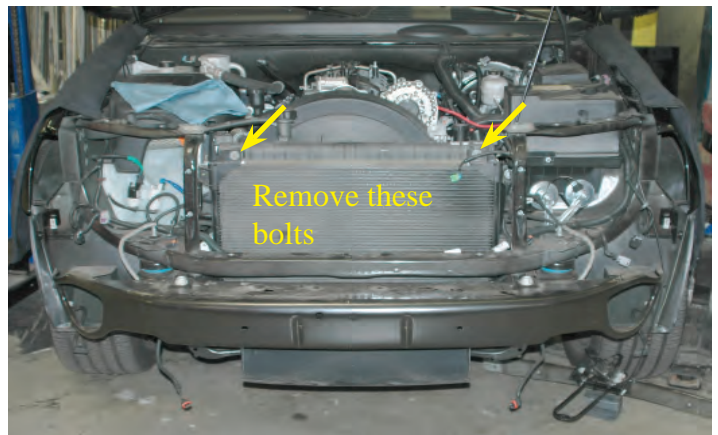

161. Apply the adhesive backed rubber strip to the back of the lower tank of the intercooler heat exchanger by removing the paper backing. The lower tank of the heat exchanger is the one with the two hose connection barbs. Apply the strip to the side of the lower tank without the barbs.

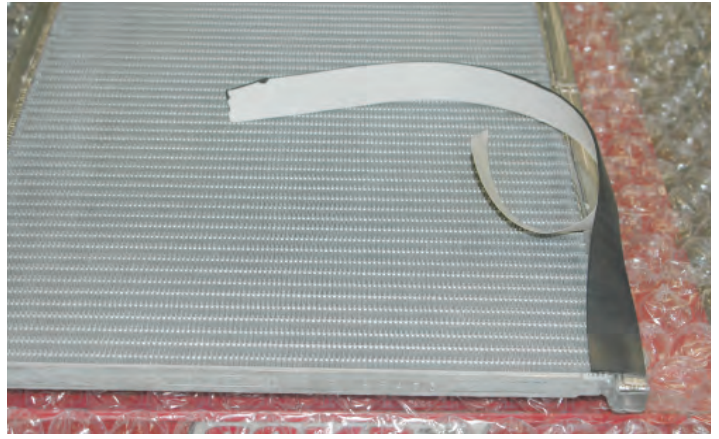

162. Install the heat exchanger on the front of the A/C condenser. The two mounting brackets will align with the two bolts previously removed. Note: The location of the vent fitting on the top tank of the heat exchanger.

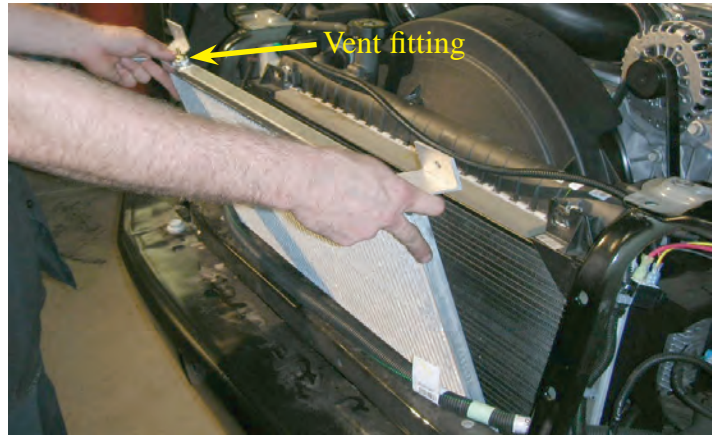

163. Attach the heat exchanger to the front of the A/C condenser with the two new bolts supplied. Tighten these bolts securely with a 10mm wrench.



164. Connect one end of the vent hose supplied to the vent fitting on the top of the heat exchanger. Route the hose over the top of the radiator and into the engine compartment. The remaining end of the hose will be connected in a later step.

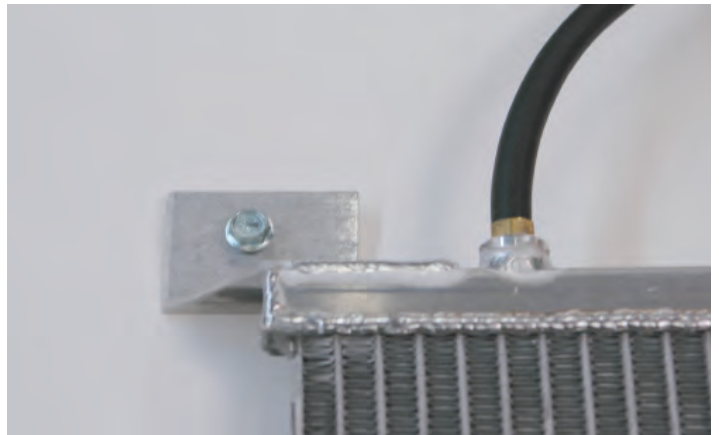

165. Replace the front cross member and latch assembly with its five fasteners. Do not forget to install the spacers under the top four bolts. Tighten all fasteners securely.

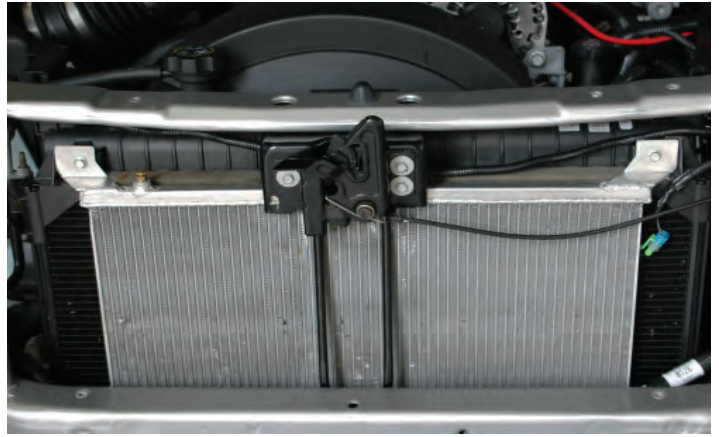

166. Replace the battery bar with its three fasteners. Tighten all fasteners securely.



167. Locate the head light frame. At the top of the center section vertical legs, measure 3/8" from the back edge and draw a line across the top surface as shown.

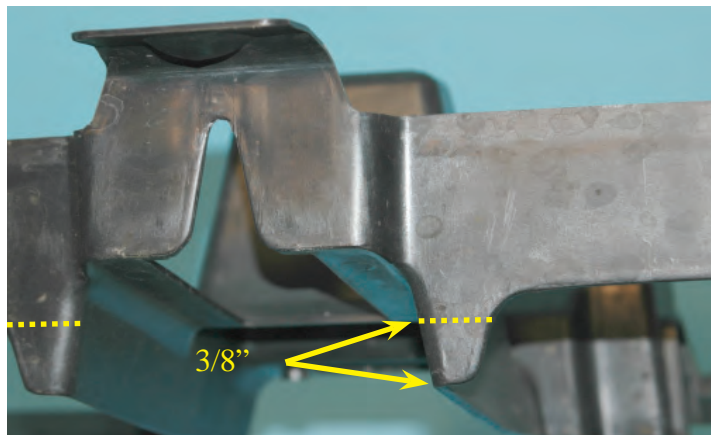

168. Next, make a diagonal line from the top surface to the bottom surface as shown. Using a file or small grinder, remove the material below the line drawn.

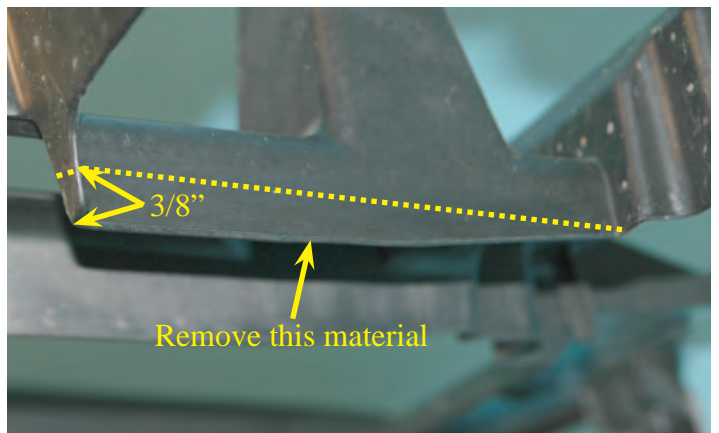

169. Temporarily set the head light frame back into place and check that there is at least 1/8" clearance between the headlight frame and the heat exchanger. Additional trimming may be necessary.

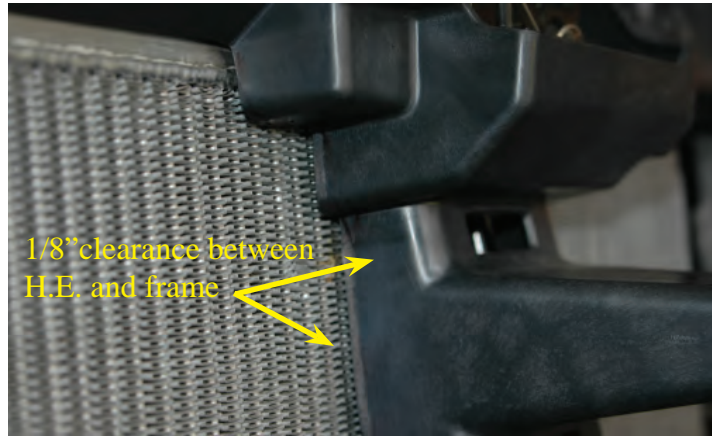

170. Once there is clearance between the headlight frame and the heat exchanger, replace the headlight frame and re-install its ten fasteners.



171. Route the small black electrical plug for each head light over the top corners of the frame.

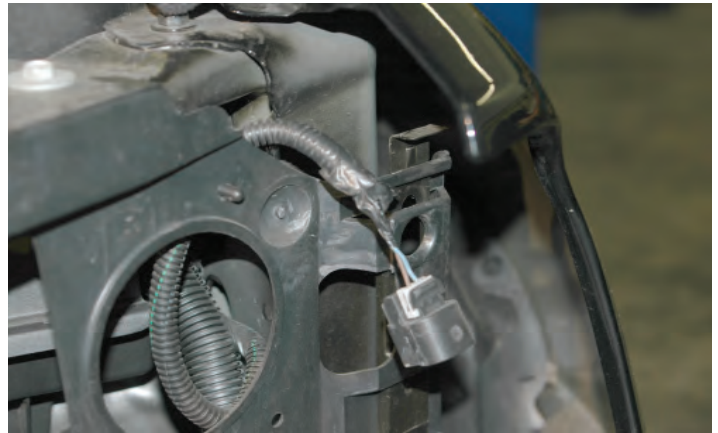

172. Here is the intercooler pump with its mounting and wiring hardware.



173. On the outside of the passenger side front frame rail, just ahead of the front wheel, drill two 3/16" holes to mount the intercooler pump. Measure 3-5/8" from the backside of the body mount and draw a vertical line. Measure 1-1/2" and 3-5/8" down from the top of the frame rail drill a 3/16" hole at these points on the vertical line.

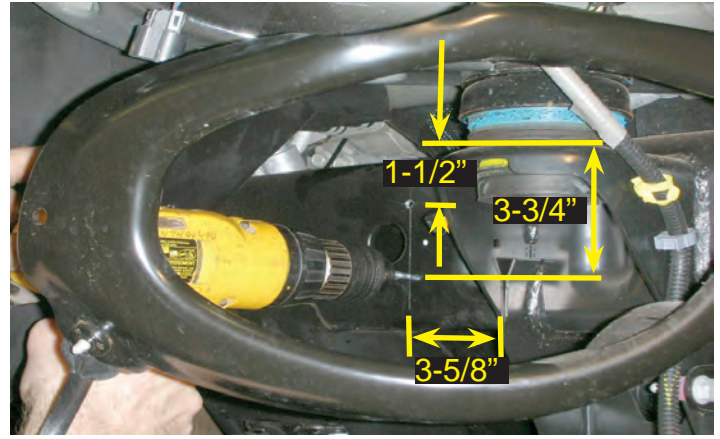

174. Install the mounting clamps around the body of the intercooler pump and pass the self-tapping bolts supplied through the holes in the clamps and into the holes in the frame rail.



175. The intercooler pump will mount in this position with the pump outlet barb pointing towards the front of the vehicle. Tighten the self-tapping mounting bolts with a 10mm wrench securely.

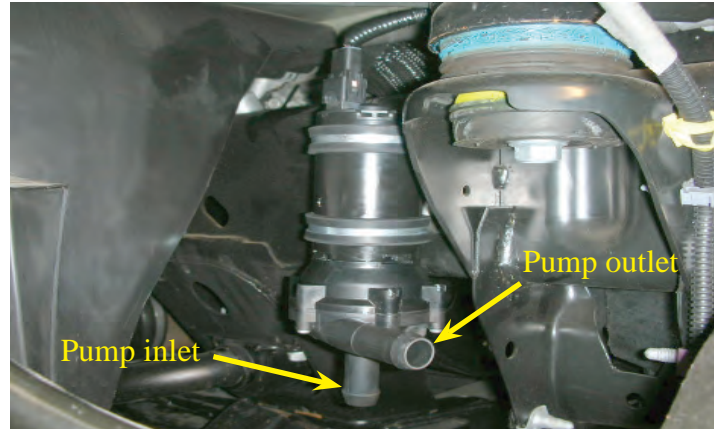

176. This is the intercooler reservoir bottle with its mounting hardware.



177. On the passenger (right) side of the engine compartment locate the large A/C line next to the engine. Place the two-intercooler reservoir bottle mounting clamps around the line as shown.



178. Install the intercooler reservoir bottle on the A/C line by passing the two mounting bolts through the mounting clamps and into the two holes in the bottle.

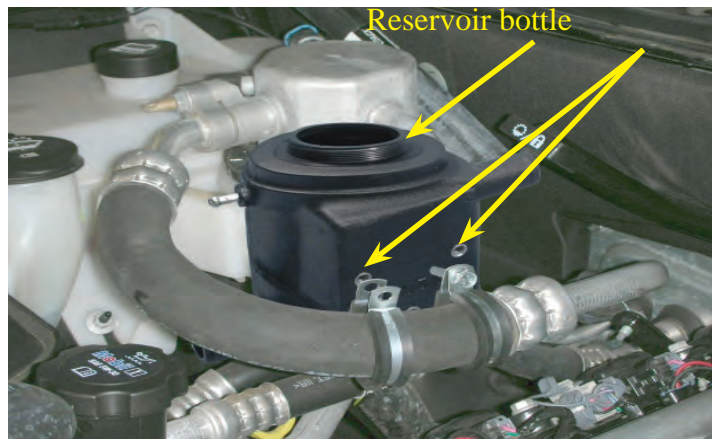

179. Locate one of the two 60"x 4" "Elbow" hoses supplied with the system and cut 18" from the long, 60" length. Connect the short 4" end to the intercooler pump inlet. Route the free end of the hose into the engine compartment by passing it beside the radiator on the passenger (right) side.



180. Connect the remaining end of the elbow hose to the front barb of the reservoir bottle. Secure the reservoir end using a provided worm gear clamp. Secure the other end of the hose with a clamp supplied (this clamp may be spring or worm gear type).



181. Locate the 36"x 4" "Elbow" hose and the remaining 60"x4" elbow hose supplied with the system. Trim 3" from the short 4" ends as shown.

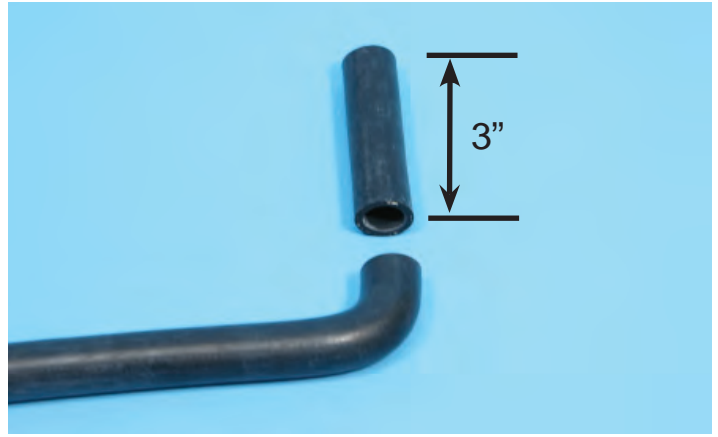

182. Connect the shortened end of the 36" elbow hose to the driver side barb of the heat exchanger. Connect the remaining end to the pump outlet barb. Secure both ends of the hose with the spring clamps provided.



183. Cut 15" off of the 60" x 3/4" x 90° elbow hose. Install the short end of the "Elbow" hose onto the passenger barb of the heat exchanger using the provided clamp. Route the free end of the hose into the engine compartment by passing it beside the radiator on the passenger (right) side.



184. Use the provided clamps to connect the other end of the elbow hose to the provided hose coupling (hose mender). Cut a piece of the provided 3/4" hose to 23" in length. Use a provided clamp to connect one end to the remaining barb on the hose coupling (mender).



185. Use the provided clamps to connect the other end of the extended hose to the driver side barb of the water manifold. Secure all ends of the hoses with the spring clamps supplied.

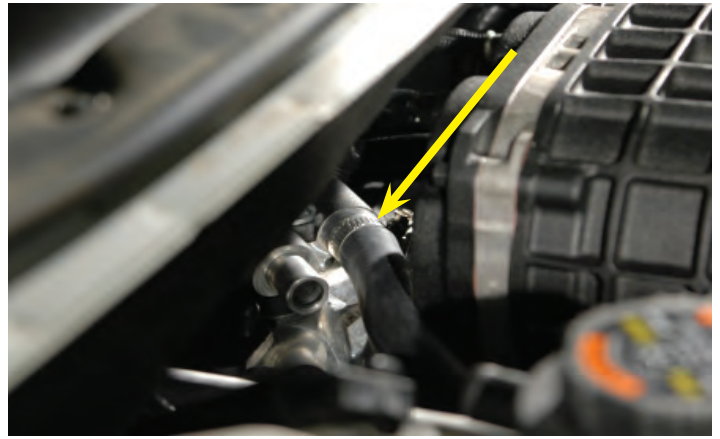

186. Cut a section of hose to 14" in length. Connect one end to the remaining (passenger side) hose barb of the supercharger water manifold.



187. Connect the other end of the hose to the supercharger reservoir using the supplied #10 worm gear clamp.



188. Connect the remaining end of the heat exchanger vent hose to the front barb on the reservoir bottle.



189. Plug the harness connector into the end of the intercooler pump.

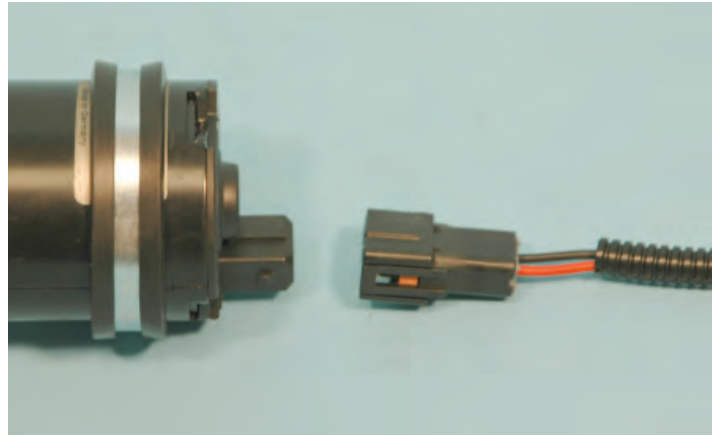

190. Remove battery positive (+) cable connection at the fuse/Relay center with a 7mm wrench. Place the ring connector of Red wire from the I/C relay under the cable and re-install it. Tighten the connection securely.

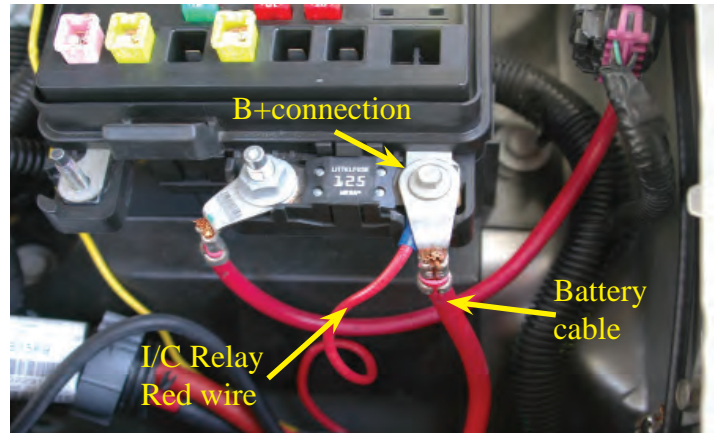

191. Remove ground connection on the inner fender well behind the battery with a 10mm wrench. Place the ring connector of Black wire from the I/C relay under the cable and re-install it. Tighten the connection securely.

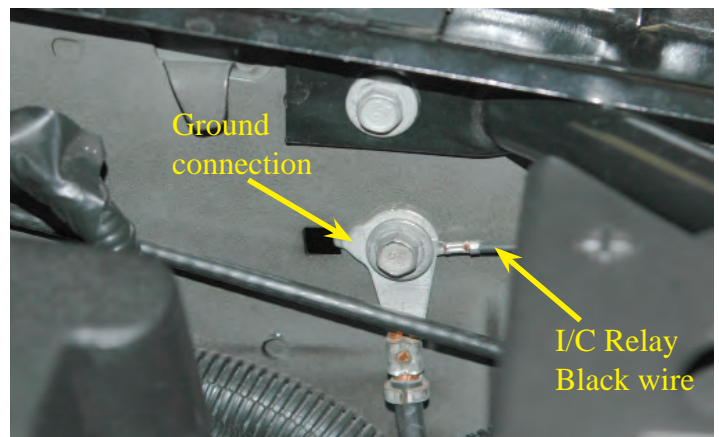

192. Remove the outer and inner covers of the fuse/relay center. Locate the #22 "IGN E" 10 Amp fuse and remove it.

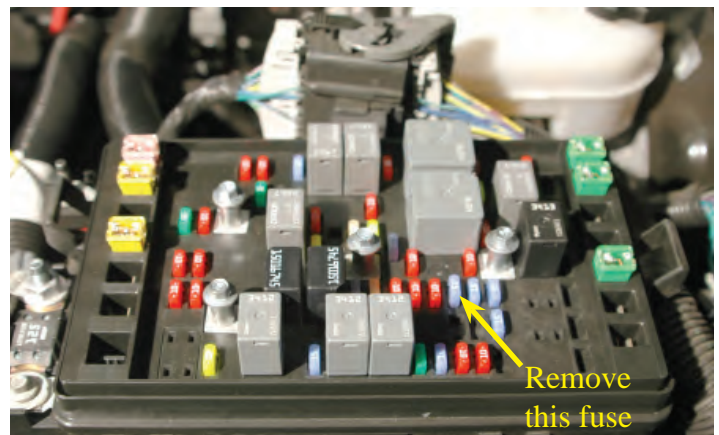

193. Locate the 15 Amp fuse and “fuse-tap” supplied. Install the fuse-tap onto the fuse as shown by passing one of the legs of the fuse through the slot in the fuse-tap.

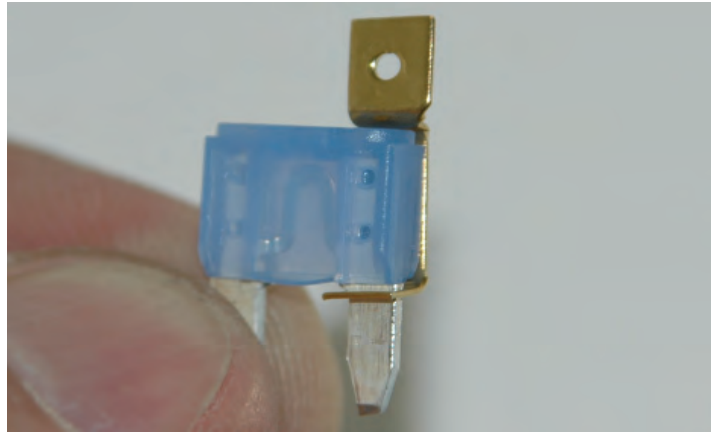

194. Install the new 15 Amp fuse and fuse-tap into the #22 IGN E slot as shown.

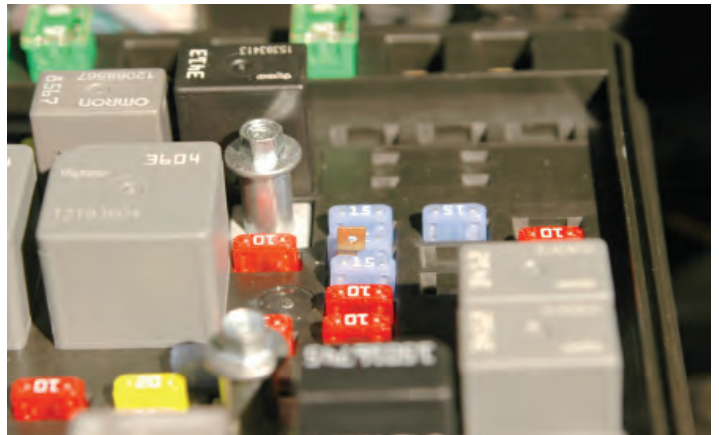

195. Route the Yellow wire from the I/C relay to the fuse/relay center. Remove the insulation from the end of the wire and install the small female spade connector supplied onto it.

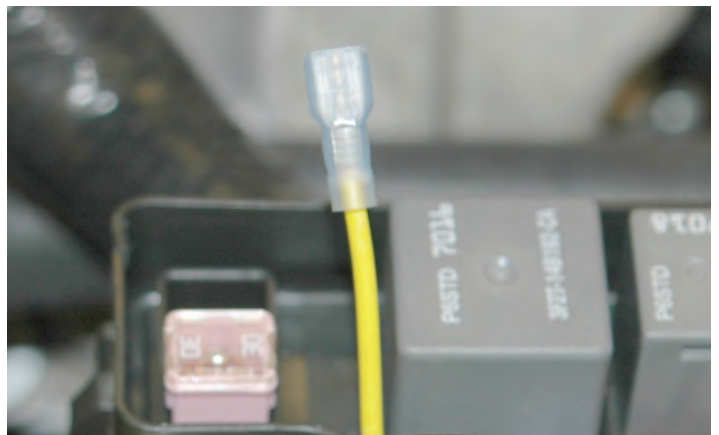

196. Route the Yellow wire so the wire passes over the battery positive (+) terminal as it exits the fuse/relay center.

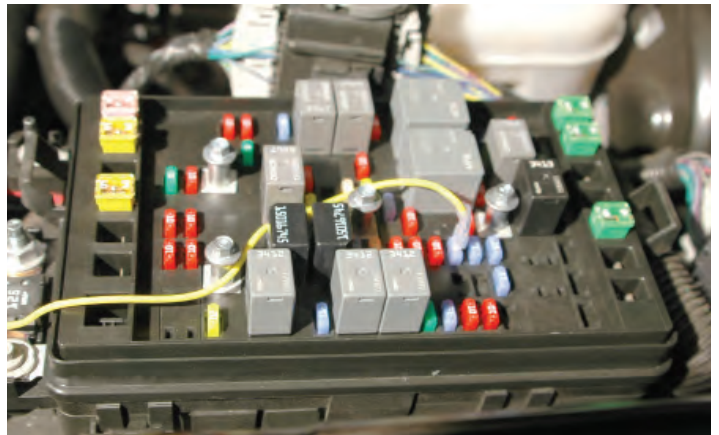

197. If your vehicle has one, re-install the inner cover of the fuse/relay center. Note the position of the yellow wire.



198. On the under-side of the fuse/relay center outer cover, use a small grinder or a sharp knife to create a notch for the Yellow wire to pass the inner seal in the area of the B+ terminal.

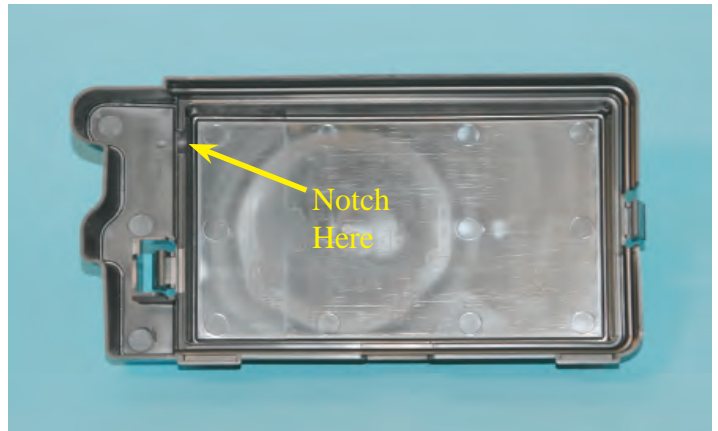

199. Replace the outer cover on the fuse/Relay center. Ensure that the Yellow wire from the I/C relay is not crimped or damaged with the cover installed.

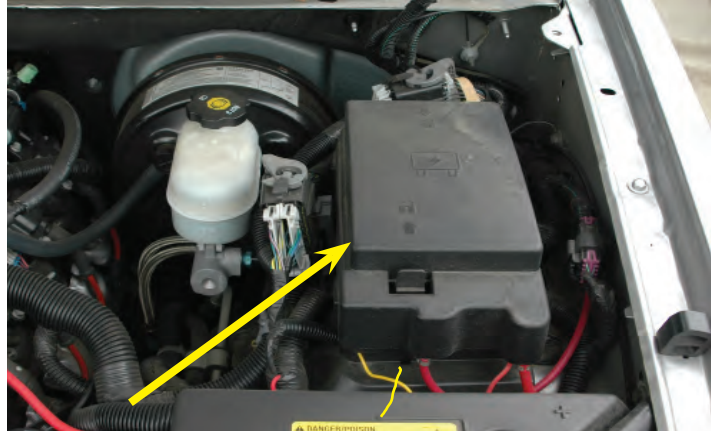

200. **The following steps describe modifications to the wiring harness necessary to install the super-charger. Additional diagrams are located in the back of this instruction manual showing these modifications.**

201. Remove the wiring harness mounting bracket from the harness.



202. Locate the MAF connector on the wiring harness. The MAF connector is located at the front of the passenger (right) side branch that supplies the fuel injectors and ETC and AC. Remove the black tape and split loom from the MAF connector and wires.

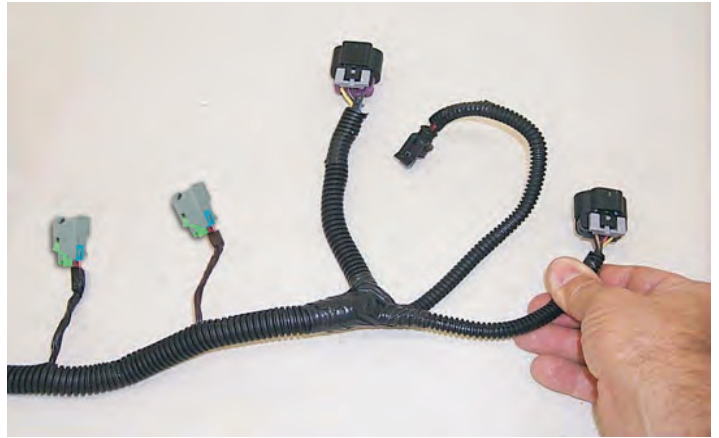

203. Locate the Tan and the Black wires that are next to each other on the connector, these are the Intake Air Temperature (IAT) circuit. Approximately 1" back from the MAF connector cut these wires.

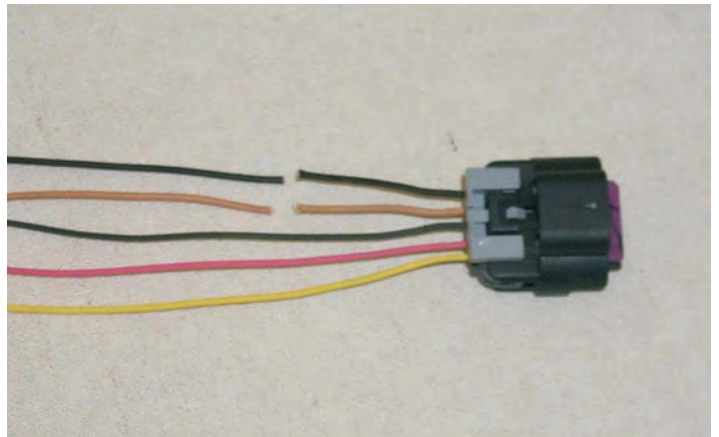

204. Cut the supplied white wire in half. Using the new IAT harness and crimp/shrink connectors supplied, connect the white wires to the tan wire and the black wire that run to the vehicles computer. The wires to the MAF connector will no longer be used. Strip about 1/4" of insulation from the ends of the black and tan wires to the computer and the IAT harness, when done, crimp the connectors on.

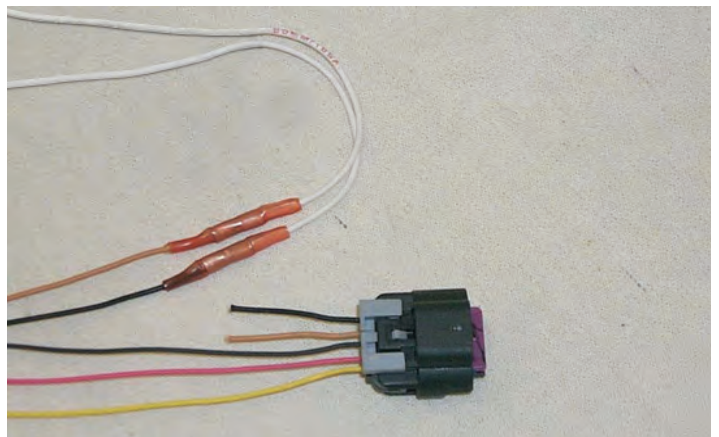

205. Using a heat gun or blow dryer set on HIGH; shrink the insulation on the connectors so that it contracts around the wires completely. You must shrink the insulation, as crimping the connectors alone is not enough to secure them! Re-cover the remaining MAF wires with the 1/4" split loom and tape.



206. If your vehicle had one, re-secure the harness to the mounting clamp near the drivers-side coil pack.



207. At the rear of the supercharger on the driver side, plug in the new MAP and IAT connections.



208. On the driver (left) side of the engine, reconnect the alternator, injector #1, coil pack, injector #3, #5, #7, and EVAP connectors.



209. On the passenger (right) side of the engine, re-connect the coil pack, injectors #2, #4, #6, #8 and MAF connectors. Remove the previously installed tape on the Air Conditioning (A/C) pressure switch and re-install connector.



210. Reconnect the Electric Throttle Control (ETC) on the throttle body.



211. Here is the new air tube and mounting components.



212. Assemble the air tube as shown. **Note: The PCV barb located on the side of the air tube.**

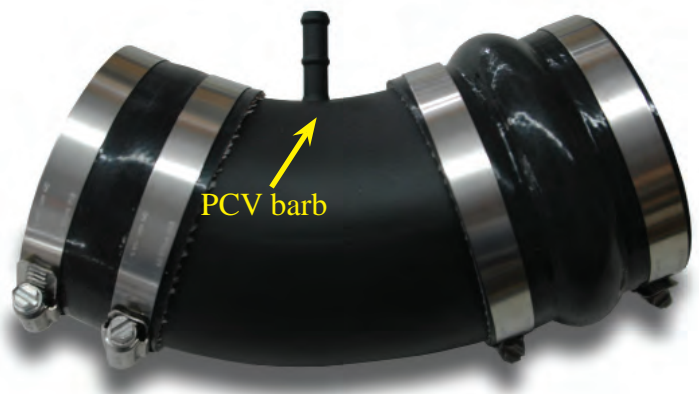

213. Install the air tube between the throttle body and the MAF unit. **Note: Place the hump hose coupling on the Throttle Body side.**



214. Tighten all the clamps at this time.



215. Remove the four screws and one push-rivet that secure the air filter cover with a crosshead screwdriver.



216. Remove the air filter cover.



217. Use an 8mm nut driver to remove the stock air filter and replace it with the K&N filter supplied. Replace the cover and push rivet, tighten the cover screws securely.

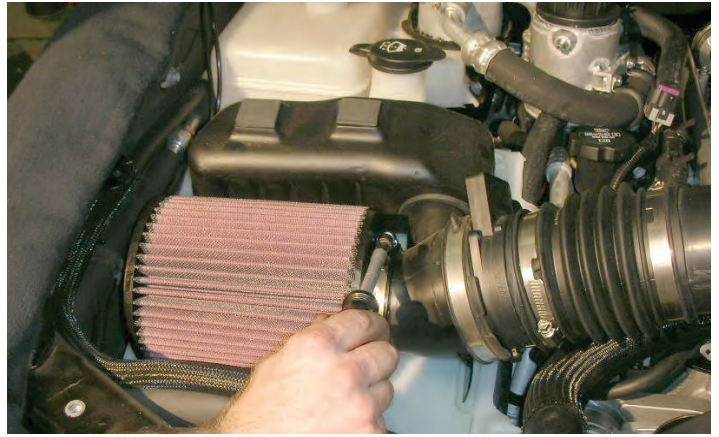

218. Connect one end of the 12" length of 3/8" hose to the barb on the passenger (right) side valve cover.

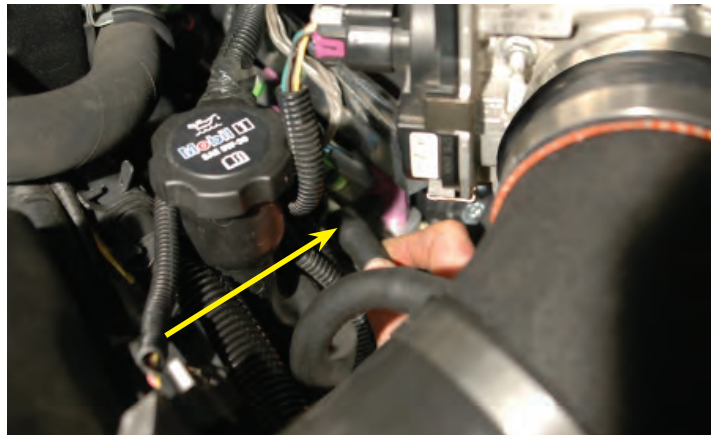

219. Connect the remaining end of the 3/8" hose to the PCV barb on the air tube.



220. Replace the battery negative (-) cable on to the battery. Tighten the clamp with a 8mm wrench.



221. Replace the front fascia with its original fasteners. **Note: That access to replace the four push rivets that secure the top edge of the air inlet can be gained by pulling the bottom edge of the fascia forward to create a gap so you can reach them.**



222. Re-install the headlight assemblies by re-attaching the three electrical connectors, and then pushing the assemblies into position. Be sure to lock the assemblies into position by pushing the latches down.

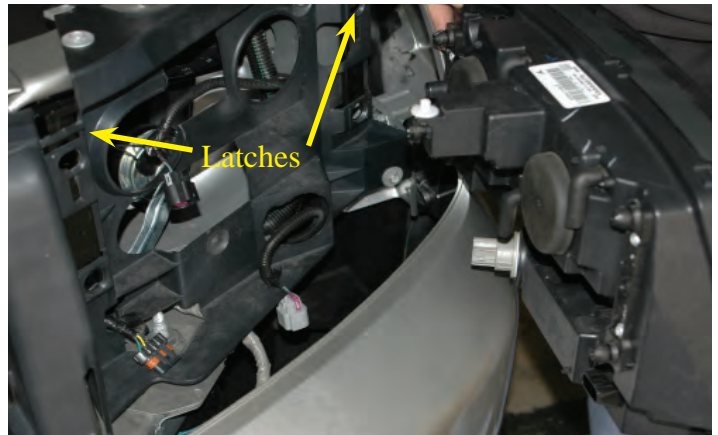

223. Carefully snap the front grille assembly into its original position.



224. Replace the front license plate mount with its four plastic push-lock rivets.



225. Replace the radiator shroud. Secure it with the original push-rivets and bolts.

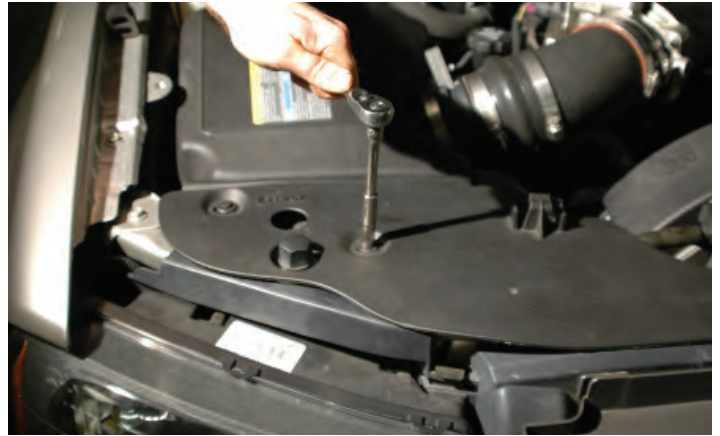

226. Install the RADIX SS Vacuum Routing Diagram, Intercooler/Belt routing information and Premium Fuel stickers on the radiator shroud.

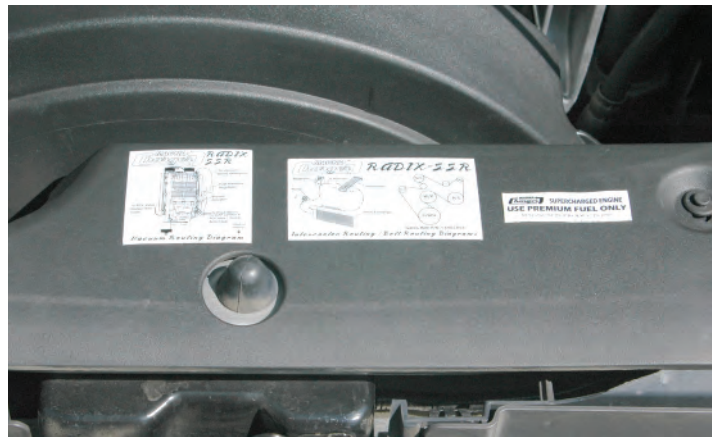

227. Re-fill the radiator reservoir and then fill the intercooler system with a 50/50 mixture of coolant and water. Check system periodically for fluid level.



228. Start the vehicle for 5 seconds and shut off, once again check for fuel leaks and fan-supercharger belt alignment. Check radiator and intercooler reservoir levels.



229. Test-drive the vehicle for the first few miles under normal driving conditions, listen for any noises, vibrations, engine misfire or anything that does not seem normal. The supercharger does have a slight whining noise under boost conditions, which is normal.



230. Re-check the intercooler reservoir coolant level regularly over the first 1000 miles.



231. After the initial test drive gradually work the vehicle to wide open throttle runs, listen for any engine detonation (pinging). If engine detonation is present let up on the throttle immediately. **Most detonation causes are low octane gasoline still in the tank.**



If you have questions about your vehicles performance, please check with your installation facility or call Magnuson Products at (805) 289-0044, Monday through Friday, 8am to 5pm.

*** PREMIUM GASOLINE FUEL REQUIRED ***

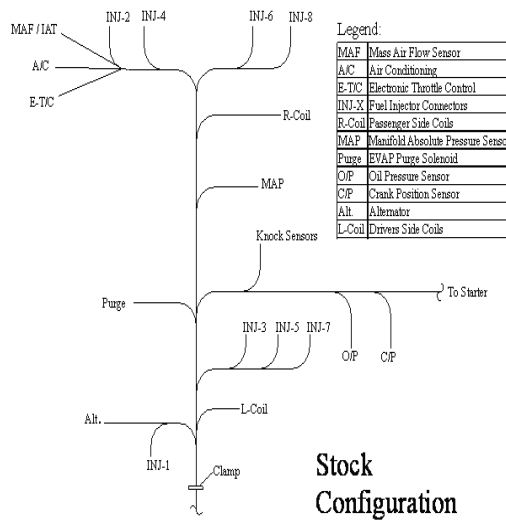
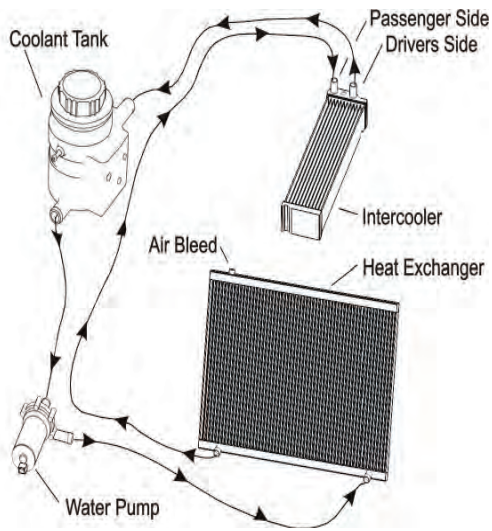

Stock Configuration

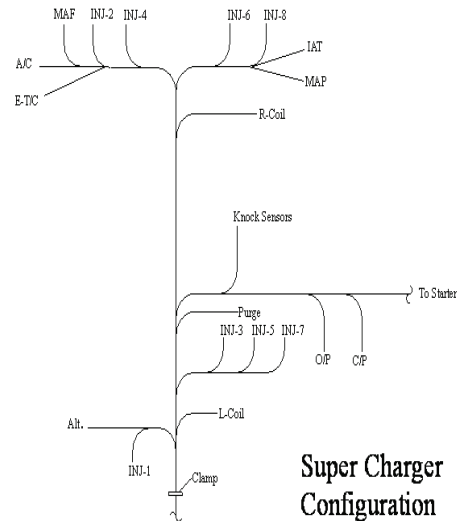

Super Charger Configuration



Please enjoy your "Magna Charged" performance responsibly.

MAGNUSON
SUPERCHARGERS