

# MAGNUSON

## SUPERCHARGERS

### Installation Instructions for: HEARTBEAT SUPERCHARGER SYSTEM 2006-2013 C6 LS7 Z06 CORVETTE



Step-by-step instructions for installing the  
**HeartBeat** of supercharger systems.

**\* PREMIUM FUEL REQUIRED \***



**ATTENTION!**  
Your **MAGNUSON SUPERCHARGER** kit  
is sensitive to corrosion!  
Take care of it by using **50/50**  
anti-freeze with distilled water.

Magnuson Products LLC  
1990 Knoll Drive, Bldg A, Ventura, CA 93003  
(805) 642-8833 phone \* (805) 677-4897 fax  
[magnusonsuperchargers.com](http://magnusonsuperchargers.com)

# INSTALLATION MANUAL

## Magnuson Supercharger Kit GM 7.0 Liter Engine Chevrolet Z06 Corvette 2006-2013 C6 LS7 HeartBeat

Please take a few moments to review this manual thoroughly before you begin work: Make a quick parts check to make certain your kit is complete (see shipper parts list in this package). If you discover shipping damage or shortage, please call our office immediately. Take a look at exactly what you are going to need in terms of tools, time, and experience. Review our limited warranty with care. When unpacking the supercharger kit DO NOT lift the supercharger assembly by the black plastic bypass actuator. This is pre-set from the factory and can be altered if used as a lifting point!

Caution: Relieve the fuel system pressure before servicing fuel system components in order to reduce the risk of fire and personal injury. After relieving the system pressure, a small amount of fuel may be released when servicing the fuel lines or connections. In order to reduce the risk of personal injury, cover the regulator and fuel line fittings with a shop towel before disconnecting. This will catch any fuel that may leak out. Place the towel in an approved container when the job is complete.

**Use only premium gasoline fuel, 91 octane or better.**

Magnuson Products recommend that you run a minimum of one (1) tank of premium fuel through your vehicle prior to installation of the system to prevent any possible damage that may occur due to running the supercharged engine on lower octane fuel.

Magnuson Products Supercharger systems are designed for engines and vehicles in "GOOD" mechanical condition. Magnuson Products recommend that a basic engine system "Health Check" be performed prior to the installation of this supercharger system. Be sure to check for any pending or actual OBDII codes and fix/repair any of the stock systems/components causing these codes. If there are codes prior to the installation they will be there after the installation.

Magnuson Products also recommend the following services to be performed on your vehicle before starting and running the vehicle post supercharger system installation:

- Fuel Filter change
- Engine oil and filter change using brand name oil (organic or synthetic) and filter
  - o Note\*: It is VERY IMPORTANT to use the factory specified oil viscosity. The original equipment manufacturer has selected this grade of oil to work with your other engine systems such as hydraulic chain tensioners and variable cam controls. Deviation from this specification may cause these systems to fail or not function properly. Please refer to your owner's manual for the recommended oil viscosity for your engine and application.
- On newer vehicles not requiring new spark plugs it is important to verify the spark plug air gap.

On older vehicles Magnuson Products recommend these additional services to be performed:

- New spark plugs with the air gap set at the factory specifications OR new specifications if required by the installation manual.
- Coolant system pressure test and flush. **NOTE: YOU MUST USE GM SPECIFIED COOLANT, AND REVERSE OSMOSIS DEIONIZED WATER (RO/DI)!**

Non "Magnuson Approved" calibrations or "tuning" will Void ALL warranties and CARB certification.

After you finish your installation and road test your vehicle, please fill out and mail in the limited warranty card, so we can add you to our files (this is important for your protection).

**Drives belt = Gates #K061005 (2006-08) or #K060980 (2009-13)**  
**Air Filter = TKO 1001-99T**

## Tools Required

**Metric wrench set**  
**1/4" - 3/8" and 1/2" drive metric socket set (standard & deep)**  
**3/8" and 1/2" drive Ft-lbs and in-lbs torque wrenches**  
**Phillips and flat head screwdrivers**  
**1/2" breaker bar**  
**Fuel line quick disconnect tools (included in kit)**  
**Small or angle 3/8 drill motor**  
**Drain pan**  
**Hose cutters**  
**Hose clamp pliers**  
**Safety glasses**  
**Torque angle meter**  
**1/2" impact gun**  
**Small drift punch**  
**Hammer**  
**Harmonic balancer modification kit (included in kit)**  
**Compressed air**  
**Blow gun**  
**Metric Allen socket set 3/8 drive**  
**Torx socket set 3/8 drive**  
**Power steering oil suction tool or turkey baster.**

## Contact Information:

**Magnuson Products LLC**  
**Magna Charger Division**  
**1990 Knoll Drive, Bldg A**  
**Ventura, CA 93003**

<b>Sales/Technical Support Line</b>	<b>(805) 289-0044</b>
<b>Fax</b>	<b>(805) 677-4897</b>
<b>Websites</b>	<b><a href="http://www.magnusonproducts.com">www.magnusonproducts.com</a></b> <b><a href="http://www.magnacharger.com">www.magnacharger.com</a></b>
<b>Email</b>	<b><a href="mailto:sales@magnusonproducts.com">sales@magnusonproducts.com</a></b>

## TABLE OF CONTENTS

Section 1: Tuning Your Vehicle Computer and Initial Steps	Steps 1 - 6 (Pages 5 - 6)
Section 2: Removal of Factory Intake Manifold and Accessories	Steps 7 - 41 (Pages 6 - 15)
Section 3: Frame/Engine/Fan Accessory Preparation for Pinning the Crank	Steps 42 - 51 (Pages 15 - 17)
Section 4: Pinning the Crank	Steps 52 - 81 (Pages 17 - 25)
Section 5: <b>Vent Pipe Replace and Modifications, Tensioner and Power Steering Pump Modification</b>	Steps 82 - 119 (Pages 25 - 34)
Section 6: Coil Pack Removal and Modification	Steps 120 - 142 (Pages 34 - 40)
Section 7: Preparing the Supercharger and Installation	Steps 143 - 153 (Pages 40 - 43)
Section 8: Re-assembly of Frame and Sub-frame, Sway Bar Re-Install	Steps 154 - 157 (Page 43 - 44)
Section 9: Coolant Manifold, EVAP Hoses, Accessory Belt, and Throttle Body Install	Steps 158 - 166 (Pages 44 - 46)
Section 10: Injectors, Fuel Manifold, Coil Packs, Fuel Line and Brake Booster Install	Steps 167 - 195 (Pages 46 - 53)
Section 11: Prep and Exposing Areas Behind Body Panels	Steps 196 - 202 (Page 53 - 55)
Section 12: Preparation and Install of Intercooler Pump and Plumbing	Steps 203 - 236 (Pages 55 - 63)
Section 13: Intercooler Wiring.	Steps 237 - 246 (Pages 64 - 66)
Section 14: Fuel Pump Booster Installation	Steps 247 - 262 (Pages 66 - 70)
Section 15: Air Box Installation	Steps 263 - 273 (Pages 70 - 73)
Section 16: <b>Fascia Reinstallation, Coolant Fill and Testing</b>	Steps 274 - 297 (Pages 73 - 79)
Appendices: Diagram A-E	(Pages 79-83)

NOTE: This instruction manual follows the process we used to complete this installation on our test vehicle. This does not imply there aren't alternate approaches. If you find a procedure or process that improves the installation, please let us know! We'll be happy to give credit where credit is due. We strive to create the most comprehensive and complete instruction manuals available.

## Section 1: Tuning Your Vehicle Computer and Initial Steps

**Any reference to left or right side of vehicle is given from driver's seat perspective.**

1. The first step is to use the provided SCT hand-held tuner to setup the calibration for your new supercharger system. Follow the instructions in the supplied SCT tuner manual. Locate your EO sticker and follow the instructions for placing the sticker on the supercharger.



2. With a 10mm wrench disconnect the (-) negative battery cable. Make sure the cable is far enough away from the battery that it does not accidentally touch the battery and make connection during the installation. NOTE: Dry sump battery is over the rear right tire.

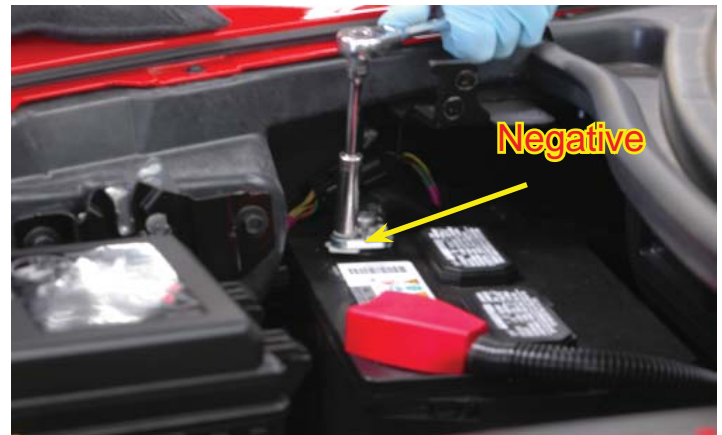

3. Raise the vehicle on an automotive hoist using the factory recommended lift points. Refer to the owners' manual or shop guide for these locations.

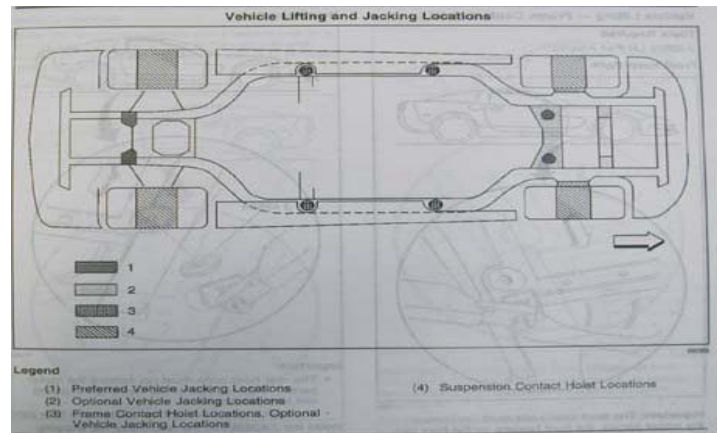

4. Remove the front right wheel (right side) with a 19mm wrench.



5. Relieve the pressure in the fuel tank by removing and then replacing the fuel filler cap.



6. NOTE: Due to vehicle manufacturing tolerances, condition of your motor mounts, age of your hood insulator, etc. we recommend removing your felt hood insulator. The insulator may contact the supercharger if left in place. Remove the stock hood by removing the four bolts with a 13mm socket wrench. Set the hood aside carefully where it won't be damaged for re-install at a later step.



## Section 2: Removal of Factory Intake Manifold and Accessories

7. With a cool engine, open the petcock drain on the right side of the radiator and release the coolant into a clean drain pan for reuse later. Be careful if the engine is still hot.



8. To facilitate drainage, remove the radiator cap to vent the system.



9. Remove the engine/coil covers by pulling up firmly on them. The covers will not be reused.



10. Unplug the Mass Air Flow meter (MAF) connector from the airbox by pulling up on the grey release trigger and squeezing the connector.



11. Remove the PCV inlet hose from the air filter bellows by pushing up on the release lever.



12. Remove the other end of the PCV hose from the sump tank. This hose will not be reused.



13. Use an 8mm nut driver or flathead screwdriver to loosen the clamp on the bellows to the throttle body.



14. Pull up firmly on the air box assembly to separate from the three mounting grommet pins and remove from the vehicle.



15. Disconnect the EVAP intake tube on intake manifold by pushing in on the white release trigger and pulling the connector free.



16. Release the other end of the tube at the bottom of the EVAP solenoid by pushing in on the release trigger.





17. Release the vent tube at the top of the EVAP solenoid by pushing in on the release trigger.



18. Disconnect the other end of the vent tube at the left side fire wall connection, this will not be reused.

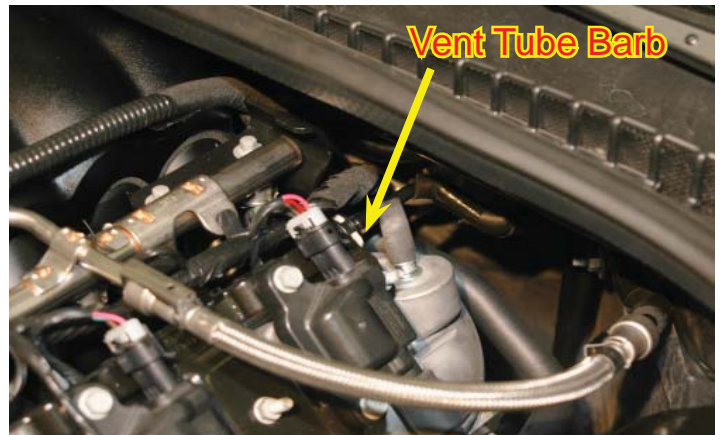

19. Remove the fitting in the location shown at the rear of the left valve cover.



20. Disconnect the other end of the PCV tube which connects to the hose barb at the front of the right side valve cover. You may need to use a small screwdriver to release the clip lock which could be on the bottom.



21. Disconnect the third fitting, and then remove the hose assembly. **This assembly can only be removed if the hardline does not tee off to the lower sump tank. Do not remove if it connects to the lower tank as this will cause an oil leak.**



22. If you have a hose assembly with the "T" intersection shown you will need to slit the plastic line at the location shown with the yellow dashed line to separate the hose from the barb. Discard the plastic section of hose you have just slit after removing it from the barb. This will be replaced later with a new branch of hoses.



23. Disconnect the EVAP solenoid electrical connection.



24. Disconnect the Electric Throttle Control (ETC) connector at the throttle body by squeezing the trigger connector and pulling to remove it.



25. Disconnect the Manifold Absolute Pressure (MAP) sensor connector.



26. Squeeze the back side of the electrical harness "tree" anchors to release the clips that secure the wiring harness to the fuel rails in four locations. Pull the "tree" anchors from the mounting holes.



27. Disconnect the eight fuel injector connectors by pressing in on the release triggers and pulling the connectors free.



28. Use a 13mm socket wrench to remove the nut that secures the battery cable on the back of the alternator.



29. Pull up on the anchors that secure the battery cable to the intake manifold and fuel rail (three locations).



30. Free the alternator cable from the intake manifold and lay it aside.



31. Remove the power brake check valve and hose from the brake booster grommet by pulling it out firmly. This will not be reused.



32. On the right side of the intake manifold behind the throttle body, remove the "U" shaped PCV hose by pressing the release clip and pulling free. Repeat on other end of the hose. If your hose does not have clip connections simply pull the hose off. Save the PCV hose for re-install at a later step.



33. Release the fuel line safety clip by prying up on the braided side of the clip. After removing the clip place some shop rags or towels under the fuel line in preparation for removal.



34. Use the fuel line removal tool to remove the fuel line from the fuel rail. To do this, first push the fuel line onto the barb firmly, hold in place while you insert the supplied fuel line removal tool into the fuel line. Push the tool into the fuel line releasing the spring clip and pull the fuel line off of the fuel line hose barb.



35. If you have caps and plugs for the fuel line, or can improvise, we recommend that you plug both the fuel line and the fuel line barb on the fuel rail to contain fuel seepage. Use shop towels to catch any dripping fuel and dispose of properly.

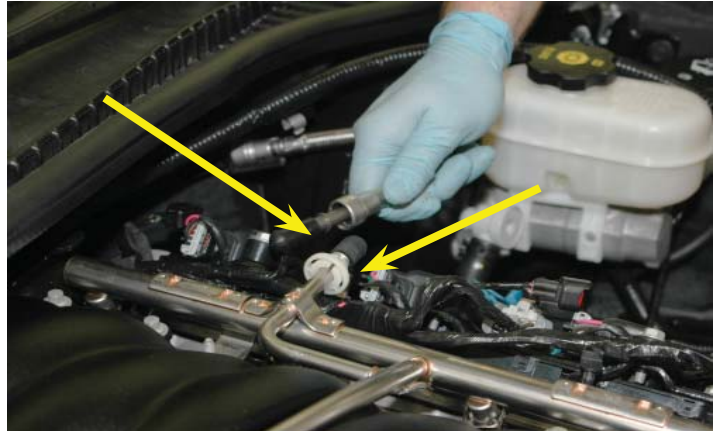

36. With an 8mm socket wrench remove the ten intake manifold bolts.

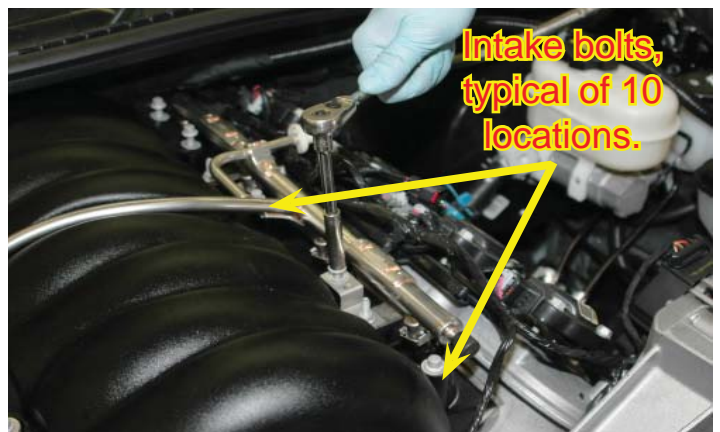

37. With the help of an assistant, feed the brake booster check valve and hose as you carefully remove the intake manifold and set it aside. Be careful to not damage the Oil Pressure Sensor harness. **If equipped with vacuum actuated exhaust you will have a second hose connected at the back of the manifold.**

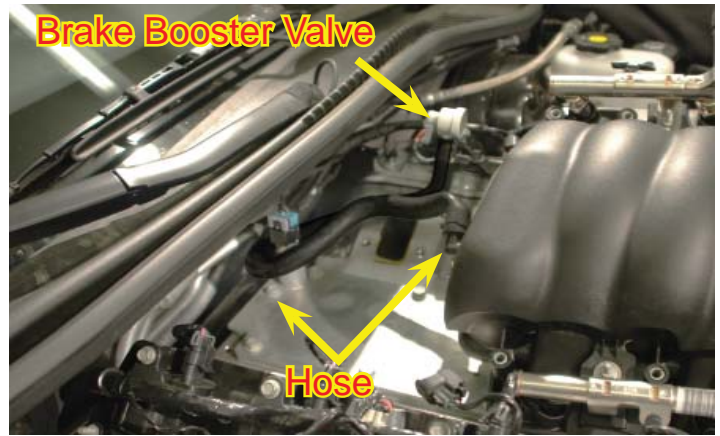

38. Using a vacuum cleaner, remove any dirt or debris from the intake port area. (Be careful not to get any debris in the intake ports).



39. Use alcohol or a suitable non-petroleum based solvent to wipe off the heads to remove any residue.



40. Cover the intake manifold ports with tape or clean rags to keep dirt and objects from entering the engine.

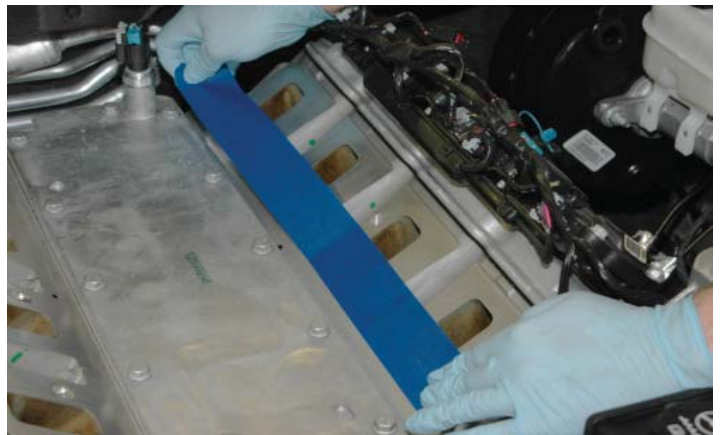

41. Unplug the oil pressure sensor electrical connection at the rear of the valley cover



### Section 3: Frame/Engine/Fan Acc. Preparation for Pinning the Crank

42. Remove the overflow hose from the clips on the radiator cowl.



43. Using a 10mm socket wrench, remove the two bolts on each side of the radiator cover.

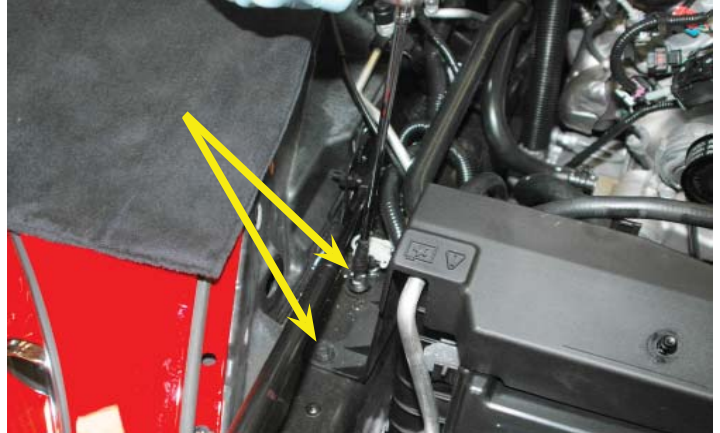

44. Remove the radiator cover and set it aside for a modification in a later step.



45. Un-clip the coolant hoses from the three clips on the fan shroud.



46. Use a small straight blade screwdriver to open the three harness clamps and release the wiring harness on the fan shroud.



47. Locate the cooling fans electrical connector under the wiring harness located on the fan shroud. Squeeze the connector firmly and pull the connector free as shown.



48. The fan shroud is held to the radiator by two bolts. The right side bolt is located near the top of the fan shroud. Use a 10mm wrench to remove this bolt.

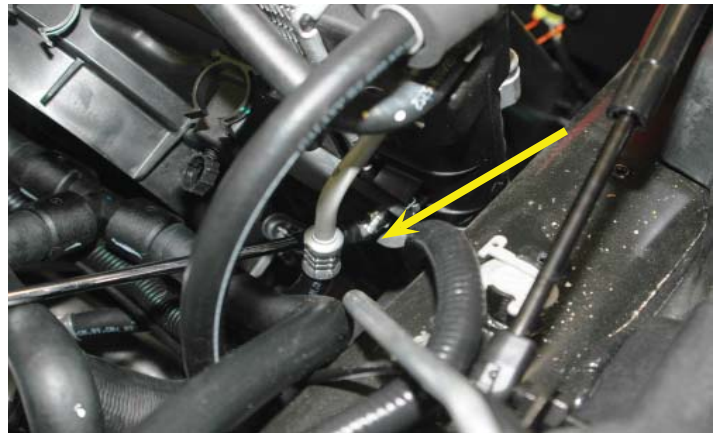



49. The left side bolt is located low on the fan shroud. This is easiest to access from below the vehicle. If you haven't done so already, use the lift point guide diagram in your owners manual to raise your vehicle for the next steps. Remove the left side fan shroud mounting bolt with a 10mm socket wrench. The fan shroud should now be free to remove.

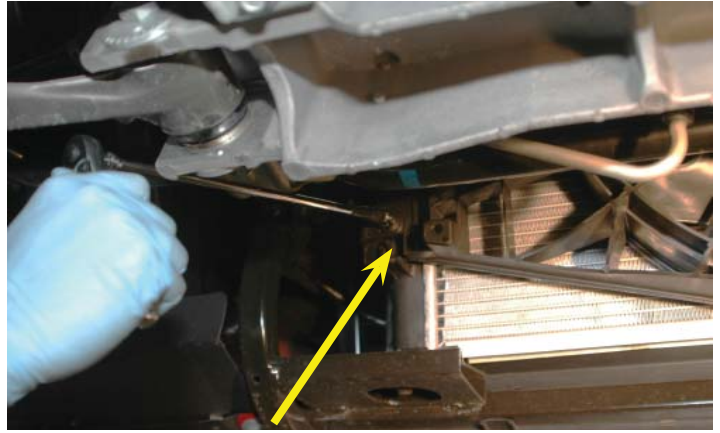

50. Unhook oil cooler hoses from the shroud.



51. Remove the fan assembly by pushing up on the fan shroud to un-clip it from the radiator and then carefully pull the assembly down and out from the vehicle completely.



## Section 4: Pinning the Crank

52. Remove the nuts that secure the sway bar end links to the lower A-arms on both sides of the vehicle. Use an 18mm socket on the outside and an 18mm open-end wrench on the inside. **NOTE:** When working with any suspension components, ensure the suspension is NOT loaded.



53. From under the vehicle, remove the four bolts that secure the sway bar brackets to the chassis with a 13mm socket wrench

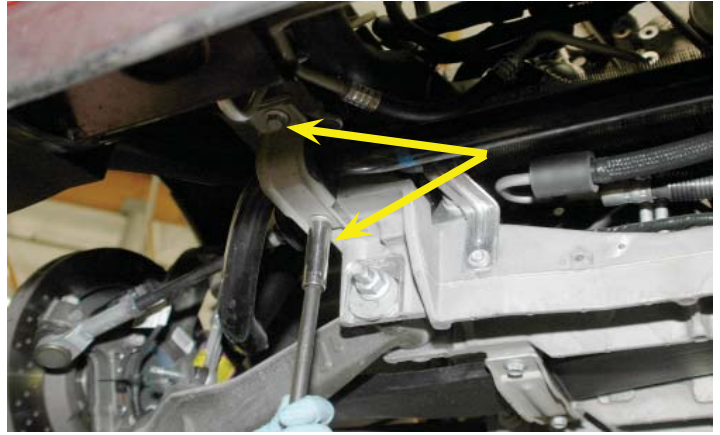

54. After removing the sway bar brackets and end link nuts, remove the sway bar and set it aside.



55. Using a 21mm socket wrench, loosen the four front sub-frame nuts shown.

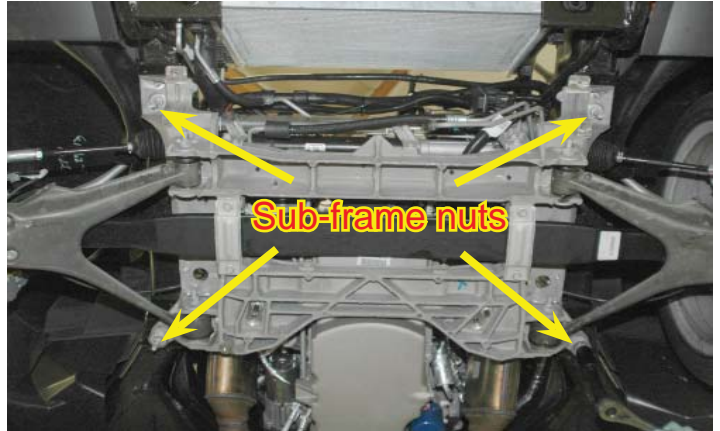

56. Loosen the four front sub-frame nuts until the bottom of the nut is even with the end of the threads on the bolt. The gap between the washer and the sub-frame should be approximately 3/4". NOTE: Loosen the nuts roughly 3/4", use a prybar and wedges to keep the sub-frame in a dropped position. The suspension will naturally pull the sub-frame upward.

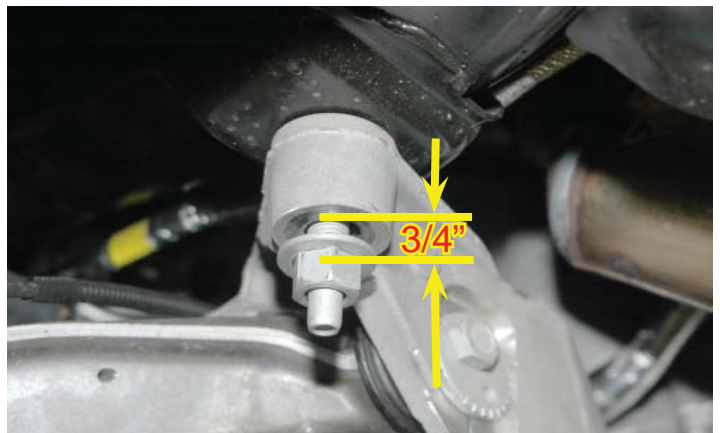

57. Remove the two motor mount nuts with an 18mm socket wrench.



58. Using a suitable pry bar, pry down the sub-frame at the front two mounting points. Temporarily push a metal or wooden wedge approximately 3/4" thick between the frame and sub frame at these points.

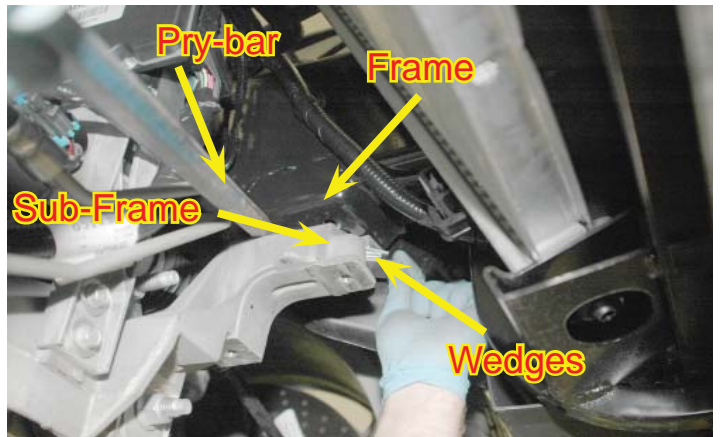

59. Use a 10 mm wrench to remove the bolt holding the transmission cooler lines to the right side of the engine.



60. Use a 10 mm wrench to remove the second bolt holding the transmission cooler lines (shown with yellow arrow). Use a 13 mm wrench to remove the bolt holding the oil sump lines (shown with a red arrow).

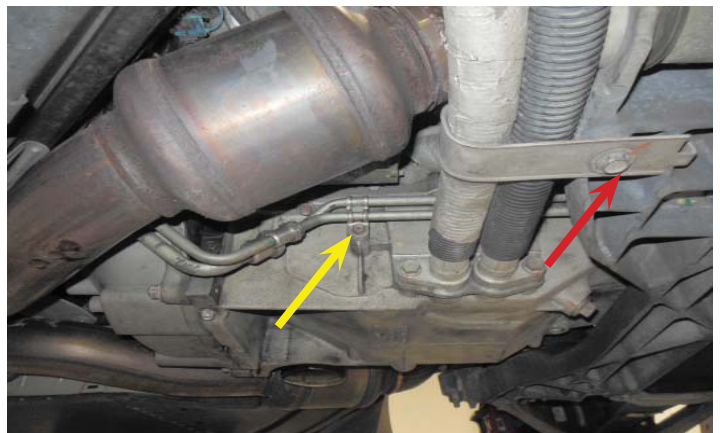

61. Using a floor jack (shown; we used a transmission jack with the car on the lift) and a sturdy piece of wood between the jack and the bottom of the oil pan, gently raise the engine. NOTE: Make sure the wood spans across the oil pan getting support from the edge bends.



62. When raising the engine with the jack, take care to watch the clearance between the back of the engine and the fire wall, so as not to damage any of the components on the fire wall.



63. Remove the two bolts mounting the power steering cooler to the frame using a 10mm wrench.



64. Swing the power steering cooler out of the way to gain access to the center of the crank pulley. You will need to unclip power steering hose directly underneath the cooler (shown with an arrow).



65. It will help to disconnect the upper power steering cooler hose. Catch the fluid in a container, plug the hose; cap the cooler.



66. Using a 16mm wrench, remove the power steering line attached to the top of the steering rack. Use a shop towel to catch any fluid lost.



67. Plug the hole at the power steering rack and cap the line as shown in the photo. Have some rags ready to catch the power steering fluid.



68. The following steps may be performed from above or below on the vehicle. For clarity some are shown from below. Remove the front harmonic balancer bolt using a 24mm impact socket and a 1/2" impact wrench. NOTE: We recommend safety glasses during all steps. Please be sure to wear them during these steps. You may need to use MAP gas (or another heat source) to heat the pulley bolt. Make sure to use caution whenever using a flame in the engine compartment and around combustible material.



69. Install the drill guide using the supplied 140 mm length bolt and tighten to 30 ft-lbs with a 24mm socket and torque wrench. Orient the holes to give you access with your drill. We found that clocking to 2:30 and 8:30 positions worked good for us.

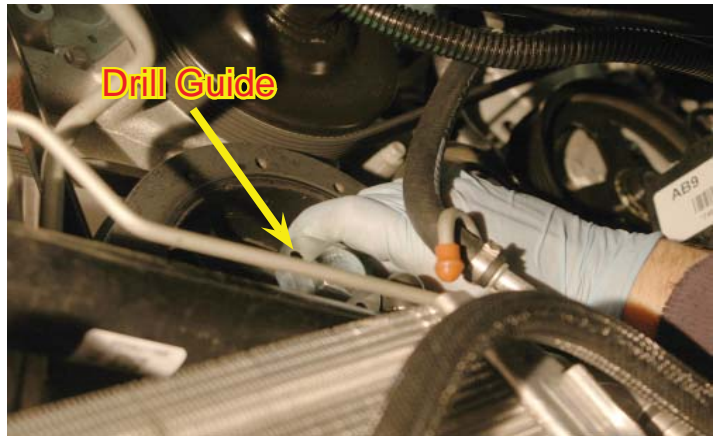

70. Using a compact 3/8" drill and the supplied drill bit, insert the drill into the guide holes and drill to the second step of the drill bit. (Make sure that you drill all the way to the second step).



71. Using compressed air, blow the drill shavings out of the holes.



72. Install the supplied reamer into drill. Using a small amount of oil, ream holes until reamer bottoms out in the holes. Try to ream each hole in one pass. This will ensure that the holes provide a tight fit for the pins.



73. Using a 24mm socket, remove the bolt and the drill guide from the engine.



74. Once again, use compressed air to blow out the holes.



75. Place beads of Green Loctite 680 on the two supplied hardened roll pins, and then insert them into the drilled holes. The use of a small hammer and punch may be necessary to tap the pins in. (Make sure that the pins are in far enough that they do not touch the balancer bolt.)



76. Install the new supplied factory GM M16 x 123 mm harmonic balancer bolt. **NOTE: DO NOT reuse the old bolt.**



77. Using a 24mm socket tighten the new harmonic balancer bolt according to General Motors specifications. Tighten to 50 Nm (37 ft-lbs) then tighten an additional 230° using a torque angle meter. The engine can now be dropped back onto the sub frame. Hand tighten the mounting bolts at this time, we will torque them down later.



78. With the crankshaft modifications complete, replace the power steering line previously removed and tighten the fitting securely using a 16mm wrench.

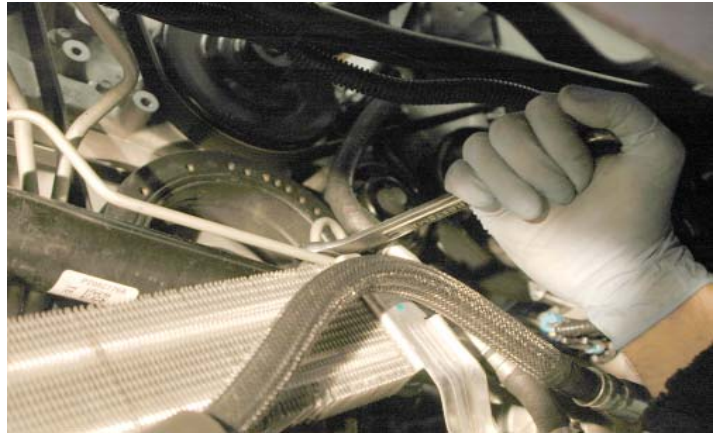

79. Remount the power steering cooler assembly to the original location and fasten using the original hardware. Reconnect the line to the power steering piston using the original snap on clamp. Torque the bolts to 106 in-lbs. The upper cooler hose will be attached in a later step.



80. Reinstall the fan assembly. Use care to not damage the radiator core, and clip the fan assembly back into place. Install the two bolts that held it into place and reconnect the fan electrical connection. Clip the wiring harness and coolant lines back into their original locations on the fan shroud. (This is a reverse of steps 40-48)





81. Connect the oil pressure sensor plug back on the oil pressure sensor.



## Section 5: Vent Pipe Replace and Modifications, Tensioner and Power Steering Pump Modification

82. Remove the accessory serpentine belt by rotating the tensioner bolt with a 15mm wrench. Once the belt has become slack, pull the belt off an idler pulley and then remove the belt, this will not be reused.



83. Remove the stock tensioner assembly by removing the two mounting bolts with a 15mm wrench. Save the tensioner and two bolts for reinstallation at a later step.



84. Remove the coolant hose from the vent pipe.



85. Remove the vent pipe with a 10mm socket wrench. Ensure that the O-ring gaskets under the vent pipe blocks do not stick to the cylinder heads. If so, remove them as new gaskets are supplied.

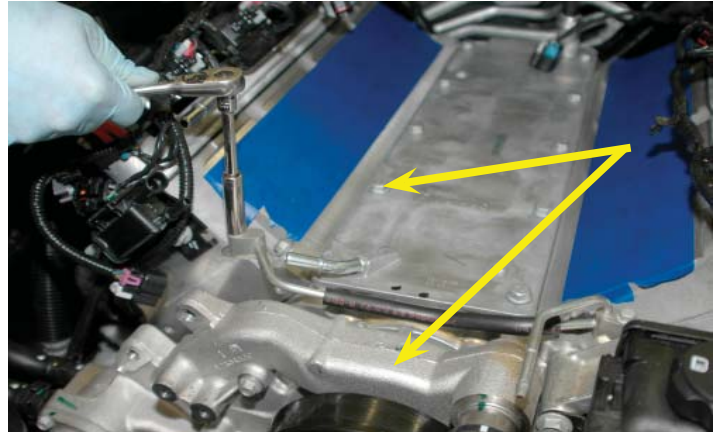

86. Rotate the barb on the front of the valley cover down by using a Phillips head screwdriver inserted into the pipe, and gently rotate downward approximately  $\frac{1}{4}$ ". Ensure the screwdriver is snug in the pipe so that the screwdriver does not damage the tube.



87. If not already installed, place the new O-ring gaskets on the vent pipe blocks using some of the supplied Lubriplate grease to hold them in place.



88. Install the new vent pipe with the original bolts and torque them with a torque wrench and 10mm socket to 106 in-lbs. Verify your torque wrench settings. Install the  $\frac{1}{4}$ " hose with the black clamp on the cross over before installing.



89. Remove the factory EVAP Solenoid and bracket on the front of the right side head using a 15mm socket. Set aside for use later.

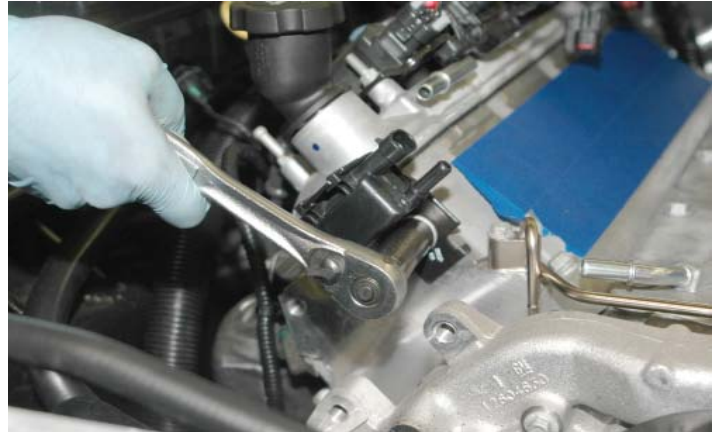

90. Remove the "T" fitting from the coolant hose that ran to the OE steam pipe.



91. Replace the removed fitting with the provided hose mender (coupling) and secure in place with the OEM clamps.



92. Move the "T" fitting so that it is in line with the right side coolant hose below, to the right of the factory tensioner mount. Be careful not to place too close to the clip on the plastic radiator cap. Secure the "T" fitting with the supplied red hose clamps.



93. Connect the "T" fitting to the barb on the coolant vent pipe. Using the supplied 1/4" coolant hose secure the hose with the two black spring clamps provided. Zip-tie the new coolant hose to the larger OEM hose.



94. Use a provided green spring clamp to attach the provided 3/8" power steering hose to the upper barb on the power steering cooler. Route this hose up and over to the right side toward the belt tensioner location.

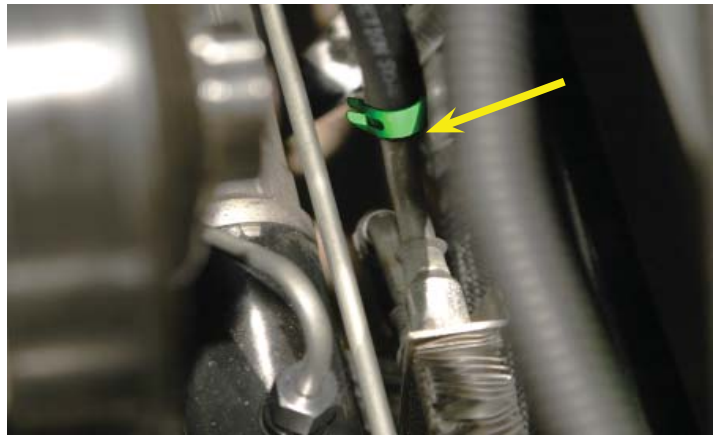

95. Using a power steering oil suction tool, turkey baste bulb, hand soap pump, or whatever you can improvise with to remove any remaining fluid from the power steering reservoir and put into a disposable container. (Old fluid can be disposed of at an oil recycling center).



96. Using a 15mm wrench, remove the two bolts that secure the power steering fluid reservoir to the alternator bracket. These bolts will be reinstalled in a later step.



97. Remove the mounting bracket from the reservoir then remove the large hose from the hose barb on the left side of the block by squeezing the clamp with a pair of pliers. We found a remote cable hose clamp plier worked best, along with a long flathead screwdriver to pry the hose off the barb. Use a shop towel to catch any residual fluid. You may need to use a hook point to separate the hose from the barb as it may stick firmly in place.

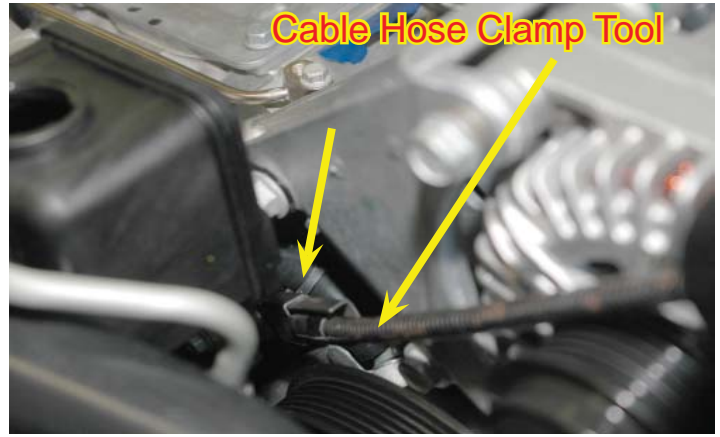

98. Remove both hoses from the bottom of the reservoir. Be careful of dripping fluid, use a shop towel and dispose of properly. It's a good idea to cover the pulleys below to avoid fluid contamination.



99. Remove the wiring harness anchor from the front of the right side cylinder head. This hole will be used to mount the relocated power steering reservoir bracket. Be careful to not damage the clip, as it will be reused.



100. Install the new power steering reservoir bracket using the new bolts supplied. Torque the bolts to 25 ft-lbs using a 15mm wrench. Ensure that the wiring harness just removed is inside the angle of the mounting bracket, not behind the bracket. Press the wiring harness anchor removed previously into the hole of the power steering mounting bracket. You may need to slide the anchor up the harness slightly to reach the hole.



101. First observe your water pump. If it looks like the one pictured continue with this step. If not skip ahead two steps to for different instructions. Remove the bolt at the yellow arrow location. This location will be used for mounting the idler bracket. The two threaded holes shown with red arrows will also be used for mounting the idler bracket in the next step.

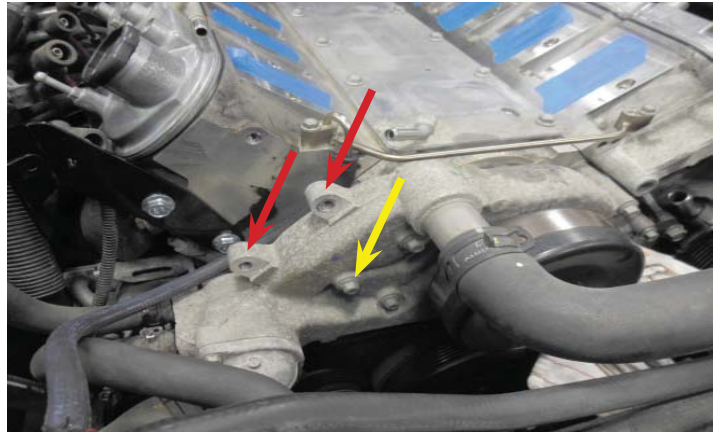

102. Install the bracket shown with the provided bolts. Torque the M10 bolts to 25 ft-lbs, and the M8 bolt to 18 ft-lbs.



103. If your water pump is of this style you use a different supplied idler bracket which is shown in the next step.

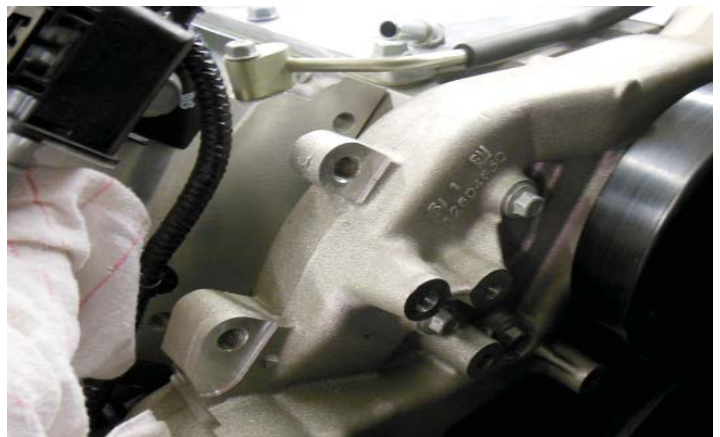

104. Install the new tensioner mounting bracket in the original location of the OEM unit with the supplied M8 and M10 hardware. The socket head cap screw goes in the pocketed hole. Torque the M10 bolts to 25 ft-lbs, and the M8 bolts to 18 ft-lbs...be sure to verify your torque wrench settings.



105. Install the OEM tensioner with the provided long two M10 bolts in the tensioner package. Torque the bolt to 25 ft-lbs. Again, verify your torque wrench settings. Model year 2008 has a different water pump.



106. Install the provided idler with the provided M10 x 25mm bolt. Torque the bolt to 25 ft-lbs. Verify your torque wrench settings.



107. Connect the length of 3/8" power steering hose from the upper barb of the power steering cooler to the smaller barb on the bottom of the power steering reservoir. Secure the hose with the green spring clamp supplied.



108. Slide the power steering reservoir into place on the new mounting bracket. **Do not fully engage the retaining clip.**



109. Install the provided 5/8" hose onto the large barb on the top of the power steering pump by the upper radiator hose on the engine. Secure the hose with the original spring clamp.



110. Install the new EVAP Solenoid mounting bracket at the OEM power steering bracket location. Use the OEM power steering bracket bolts to secure the mounting bracket in position, torque to 35 ft-lbs. Verify your torque wrench settings.

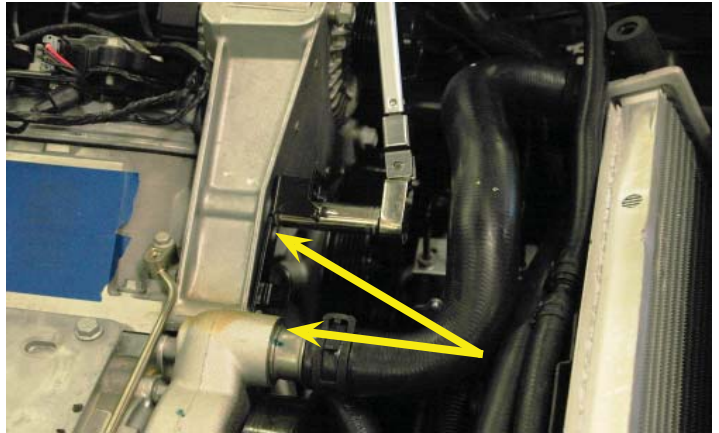

111. Use the provided "tree" zip-tie to loosely secure the 5/8" hose to the hole in the EVAP Solenoid mounting bracket just installed.

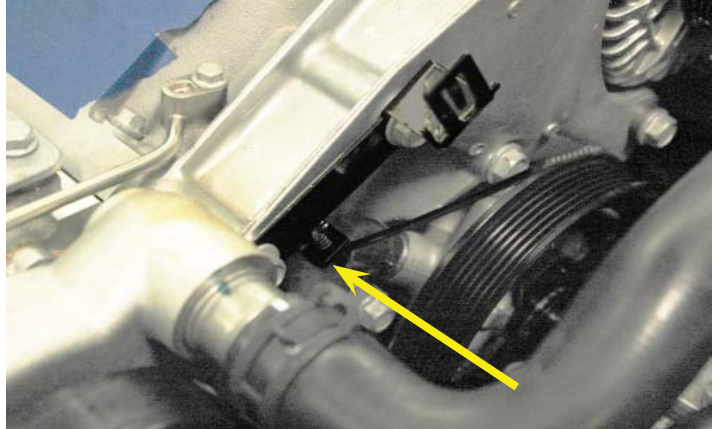

112. Route the 5/8" power steering hose forward along the fan shroud, following the same path as the coolant lines toward the right side of the vehicle, cut to fit if needed, and connect to the large barb on the power steering reservoir using the provided clamp.

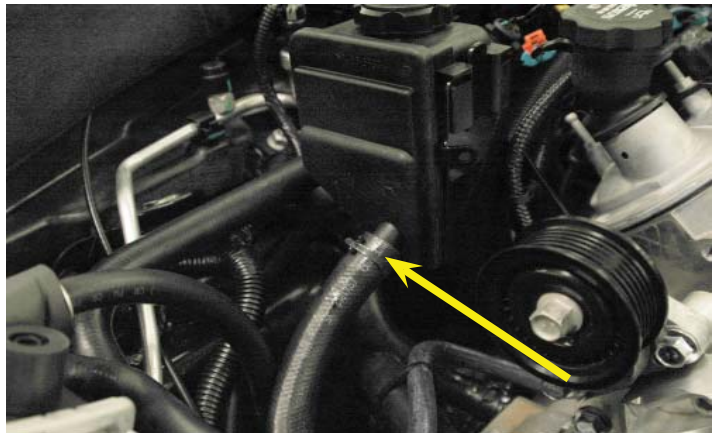



113. Route the 3/8" power steering hose below and parallel to the 5/8" hose you just ran, secure hoses with available mounting clamps and/or zip ties. Once the routing is correct, you can fully engage the P/S reservoir on the bracket.

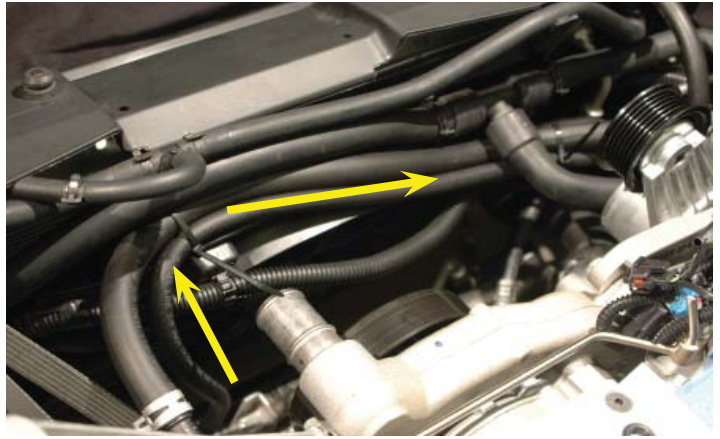

114. Slide the EVAP Solenoid onto the bracket you installed earlier. Ensure that the bracket "clips" into place.

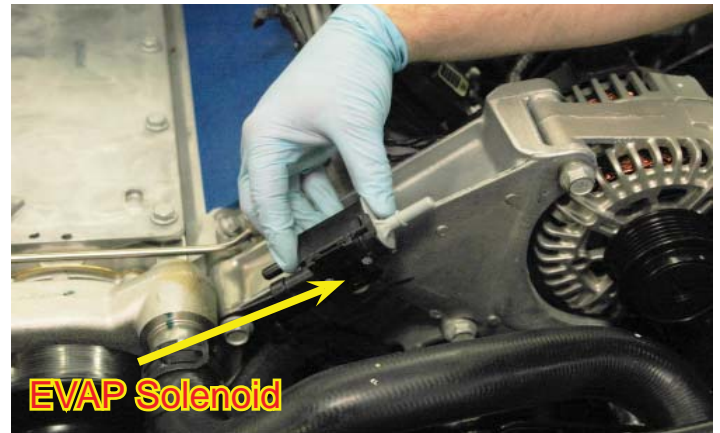

115. Connect the throttle body extension harness to the throttle body plug. Route this extension harness under the steam pipe and over toward the left side of the vehicle.

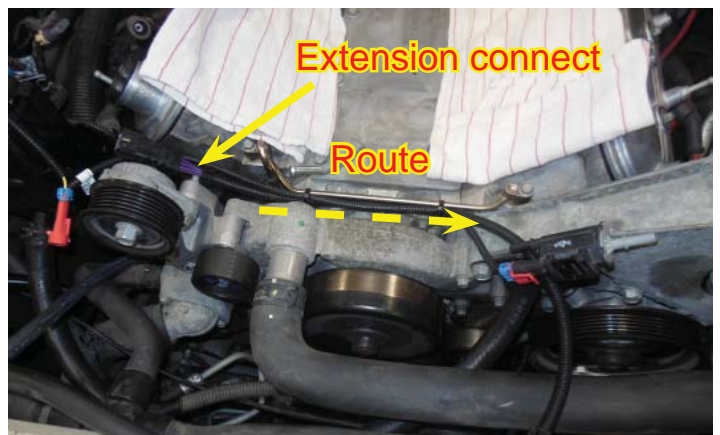

116. Connect the EVAP Solenoid extension harness to the existing EVAP plug. Route the EVAP Solenoid harness along the steam pipe and throttle body extension harness and secure both in place with zip ties. Harness should sit along-side or below the steam pipe, not above. Connect the EVAP Solenoid plug to the new Solenoid location. NOTE: The additional single wire (yellow) should be routed to the right side for connection at a later time.

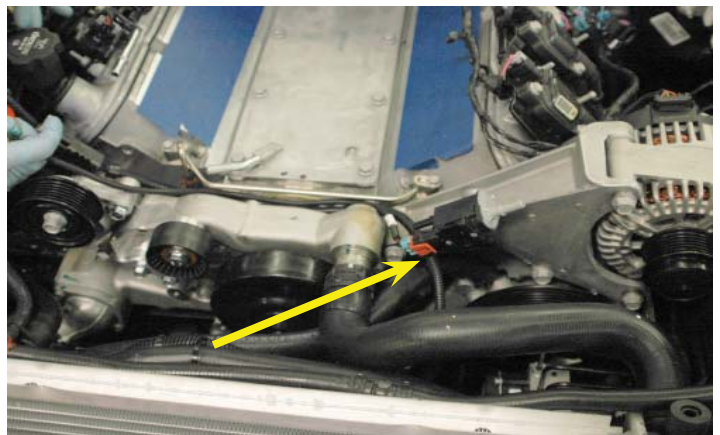

117. Gather the PCV hose. Mark the hose at the location shown with the silver line.



118. Cut the PCV hose at the lined location.



119. Install the hose back at the valley cover barb shown. Secure with a spring clamp.



## Section 6: Coil Pack Removal and Modification

120. If equipped with oxygen sensor then unplug the oxygen sensor plug from the connection on the coil bracket.



121. If equipped with the pictured connection then unclip the receiving (female) end of the oxygen sensor plug from the mounting slot on the coil bracket.



122. Disconnect the coil plug control connections from both sides of the engine.



123. Disconnect the spark plug wires from the coils.



124. Unbolt the five bolts holding the coil brackets to the valve covers using a 10mm wrench.



125. Remove the coil brackets for replacement.



126. This image shows the OEM coil pack and the new provided coil pack mounting bracket with nuts and spacers.



127. Start by disconnecting each harness wire from the coils on both OEM coil pack assemblies.



128. Use a 10 mm socket to remove the mounting bolts holding the coils to the OEM mounting brackets.



129. This is a separated coil pack set, mounting bolts, and remaining bracket.



130. Use a flathead screwdriver to release the tab holding the harness female plug terminal to the mounting brackets.



131. Pull the plug terminals away from the brackets.



132. This shows the plastic cover over the wiring harness attached to the coil pack mounting brackets.



133. Use a small flathead screwdriver to release the tabs locking these covers over the harnesses on the mounting brackets.



134. Remove the covers completely from the wiring harnesses, and separate harnesses from the mounting brackets.



135. Orient the OEM wiring harnesses with the plugs at the top, lay the bracket down over the wiring harness tongue that goes to the main female plug. The studs should be pointing up as shown in this picture.



136. Slide the metal mounting tab on the back of the plug into the slot on the new coil pack mounting brackets completely as shown. The "Teeth" of the metal tab will lock the plug in position. You can place a block, shown with an arrow, under the plug face and press the brackets down onto the plug as shown in this picture.

**Make sure the "teeth" of the metal mounting tab bite into the bracket, locking it in place.**



137. Place a provided spacer on each of the studs on the new coil pack mounting brackets.



138. Use a 10mm nut driver or wrench to secure the OEM coils to the new coil pack mounting brackets with the provided nuts. The harness female plug should be oriented to the flat "top" of the mounting brackets, the receptacle for the plug wires will be pointed in the "down" direction, same as the "tongues" of the new mounting brackets. Torque the nuts to 108 in-lb. Verify your torque wrench settings.

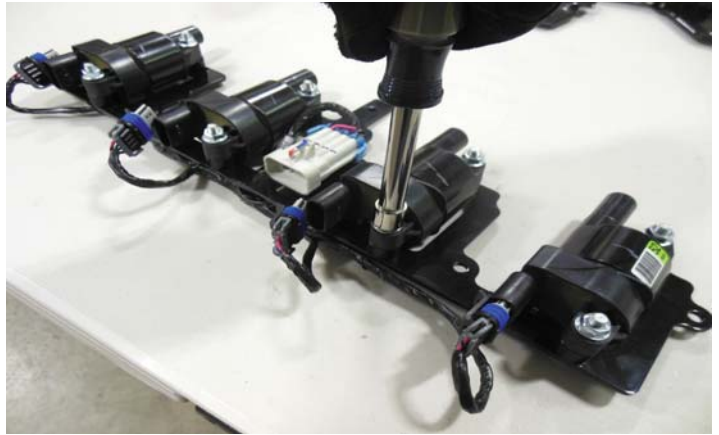

139. Connect the plugs to each of the coils on the mounting brackets.



140. This shows the completed assembly with the OEM parts that will not be reused above. Set aside the completed assembly for install after supercharger is installed on the system. We suggest that you keep your OEM parts separate in case you want to return your vehicle to "stock" and mount the supercharger system on your next Corvette.



141. Place a small amount of RTV on the intake gaskets to secure the gasket in place prior to supercharger installation.

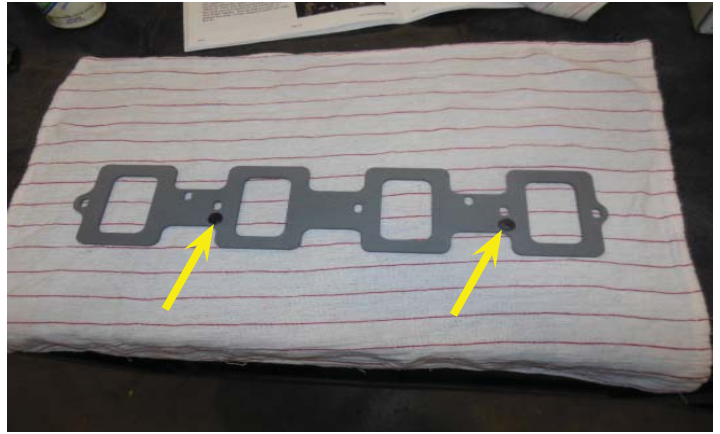

142. Remove the tape from the intake ports. Install gaskets in place with the RTV. Make sure the holes line up with the ports, and the bolt holes by threading two provided 20 mm long socket head cap screws into the holes while the RTV is drying (shown with red arrows). Repeat to opposite intake ports. On the right side of the engine there is a tube that must be rotated to the rear (shown with a yellow arrow). Place a rag over the gasket to protect the ports.

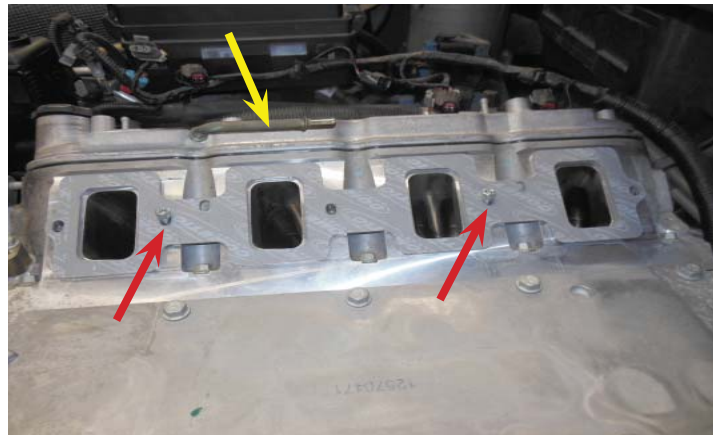

## Section 7: Preparation The Supercharger and Installation

143. The supercharger "Lid" is attached to the "Base (or Tub)" at delivery, we need to separate the two for installation. Remove the five 10mm fuel rail bolts, and pull the fuel rails carefully up and out. The injectors may come out with the fuel rails, if not, remove them as well.



144. Remove the two 3mm Allen bolts holding the two coolant manifolds to the supercharger lid. Set all the parts aside for re-assembly later. NOTE: Be careful to NOT remove the three bolts anchoring the intercooler itself to the lid of the supercharger. See arrows in second photo with coolant manifold removed: Red= Do NOT Remove, Green= Remove. Green circles show the mounting location of the bolts to remove on the lid.

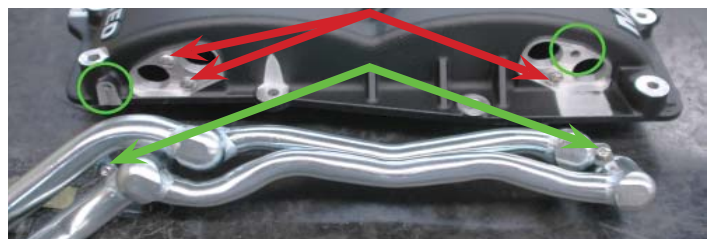



145. Remove the 10mm bolts holding the supercharger lid to the housing and pull the lid off the supercharger. The intercoolers will be attached directly to the lid. Set aside carefully for reinstall in a later step. **Take note of the locations of the different lengths of the bolts so they may be replaced in the same position.**



146. Remove the Manifold Absolute Pressure (MAP) sensor from the stock intake manifold using a Torx T-25 inverted socket. Ensure that the O-ring seal is not missing or damaged as it and the sensor will be re-used. If your sensor is clipped onto the manifold, unclip it.



147. Remove the socket head cap screws that are holding the intake gaskets to the heads while the RTV was drying. You can discard these four screws. Make sure the RTV is holding the gaskets securely to the heads. Check down in the ports and make sure they are free of any debris.



148. Ensure that the engine has been dropped back down on the sub frame and carefully, making sure you don't hit the gaskets, set the Base (Tub) on the engine. Line up the bolt holes with the holes in the cylinder heads. Make sure the supercharger is not hitting anything around the perimeter. Check the PCV hose at the front of the valley cover.



149. Apply Loctite 242 to the ends of the ten M6 x 40 mm bolts prior to installing them in the supercharger.



150. Secure the “Base (or Tub)” section in place using the provided 40mm long bolts and gradually torque down to 106 in-lbs using the order shown in the back of this manual (Diagram D) with a 10mm wrench. After completing the torque sequence make a second pass following the same order and torque a second time.



151. Apply Loctite 242 to the ends of all the fasteners for the lid.



152. Inspect the O-ring gasket from between the “Base (or Tub)” and the “Lid” for damage. Make sure orange silicone seals are properly seated in their grooves. Carefully place the upper “Lid” section onto the “Base (or Tub)” that you just installed. Replace the bolts you removed from the assembly earlier and finger tighten. Ensure that you have replaced the bolts in their original location.



153. Gradually torque down using the sequence shown in the back of this manual (Diagram E) until you reach 106 in-lbs. Verify your torque wrench settings. Remember that the two rear lid bolts are bolted "UP", not "DOWN" like the remaining bolts. It is easiest to access these two bolts from the rear-right side of the vehicle. The two bagged fasteners that were attached to the coolant cross overs should be installed in the front two holes.



## Section 8: Re-assembly of Frame and Sub-Frame, Sway Bar Re-install

154. Remove the wedges from between the frame and sub frame. Tighten the sub frame and motor mount nuts securely. See torque specs three steps ahead..If you wish to install sub frame spacers now is the time. We recommend Lingenfelter's kit #LS10050197.



155. Replace the sway bar by installing it in its original position and reconnect the end links. See torque specs two steps ahead.



156. Replace the sway bar brackets and torque to specs in the following step. NOTE: To prevent any new squeaks, you can add some chassis/suspension lube to the rubber isolators.

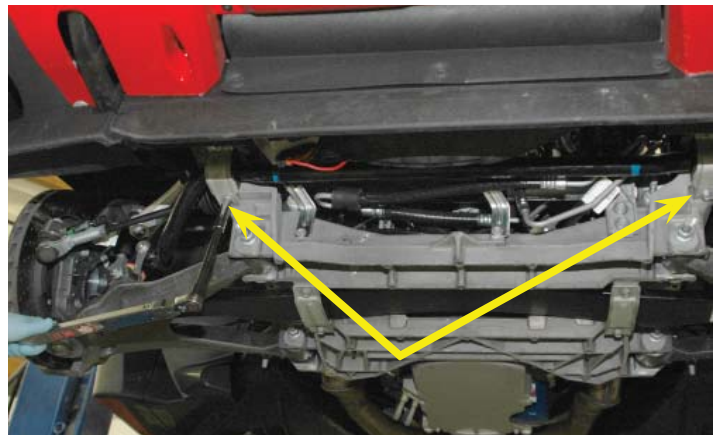

157. Torque the sub-frame, the sway-bar connections and motor mounts to the torque values below. Torque Specifications:

Engine sub-frame nuts	80 ft-lbs
Motor mount nuts	60 ft-lbs
Sway bar to frame	45 ft-lbs
Sway bar link nuts	55 ft-lbs
Wheel lug nuts	110 ft-lbs



## Section 9: Coolant Manifold, EVAP Hoses, Accessory Belt and Throttle Body Install

158. Re-install the coolant manifold hard lines, ensure the tabs are lined up so that the spigots will sit flush. The upper tube tab should be the one to sit against the lid. Use the removed hardware to install. NOTE: Use some of the supplied Lubriplate lubricant on the spigots of the hard lines before assembly.



159. Connect the blue EVAP connector to the lower barb remaining on the EVAP solenoid. NOTE: Ensure the hose runs along-side the supercharger by the injector cups.



160. Connect the yellow connector end of the provided EVAP hose to the barb on the left side of the engine compartment by the fire wall.



161. Connect the provided upper EVAP hose onto the gray EVAP solenoid barb and route the remaining end to the forward supercharger inlet hose barb, no clamp is necessary.

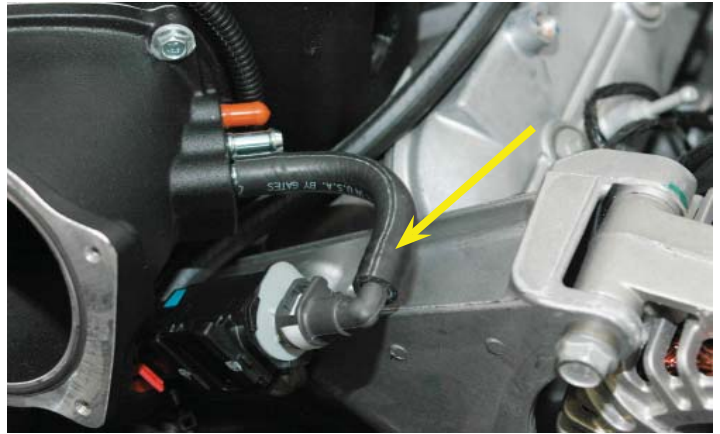

162. Install the new supplied supercharger accessory belt with a 15mm socket and wrench, using the new supplied belt routing diagram located at the end of this manual. Depending on which water pump you refer to diagram A or B, using the correct belt length mentioned.



163. Place a piece of the provided 1.5" split loom over the upper radiator hose where it will pass under the throttle body to prevent chaffing of the hose as shown. Secure with two provided 14" zip ties. **Do NOT overtighten and pinch the hose.**



164. Remove the throttle body from the OEM plastic intake manifold with a 10mm socket wrench.



165. Install the provided throttle body gasket into the groove on the supercharger inlet manifold (if not already installed), and install the throttle body onto the inlet manifold using the original bolts. Tighten the bolts with a 10mm socket and torque to 106 In-Lbs (12Nm). Verify your torque wrench settings.



166. Connect the remaining end of the throttle body extension harness to the throttle body control plug.



## Section 10: Injectors, Fuel Manifold, Coil Packs, Fuel Line, Brake Booster Install

167. Remove fuel injector clips from the OEM fuel rails and install on the new injector/fuel rail.



168. Install the fuel rails and injectors onto the supercharger manifold. Ensure that the O-rings of the injectors have been lubricated with Lubriplate lubricant. Start with the left side row and install the right side starting with the front injector and "rock" backwards to seat all injectors.



169. Start with the single front "button head" bolt loosely installed, and then install the remaining four fuel rail bolts (2 per side). Torque all 5 bolts to 106 in-lbs, verify your torque wrench settings.



170. Here are the components needed to install the MAP sensor. Apply a light layer of Lubriplate grease to the red sealing surface of the MAP sensor prior to installation (shown with a yellow arrow). Apply Loctite 680 to the outside of the bushing (shown with a green arrow).



171. Insert the bushing that had Loctite 680 applied to it in the last step into the location shown with the yellow arrow.



172. Install the MAP sensor into the location shown in the last step. Place the clip, and bolt in the threaded hole and tighten in place.



173. Identify the following fitting. This is located at the rear left side of the engine.



174. Route the supplied dry sump hose assembly behind the supercharger. Connect the 90° fitting at the location shown. Make sure the hose is not kinked.



175. Route the hose shown to the barb that was rotated 180°. Place a provided green spring clamp over the metal barb here shown with the green arrow.



176. Connect the hose from the last step to the barb and place the green clamp over the connection where shown with the green arrow. Route the wiring harness over the hose as shown.





177. Connect the opposite side of the hose from the last step to the sump barb where shown. If your vehicle has a hose assembly with a "T" to the lower sump tank, then you will have to trim the supplied hose to match up with the barb on the "T".



178. Connect the eight fuel injector plugs.

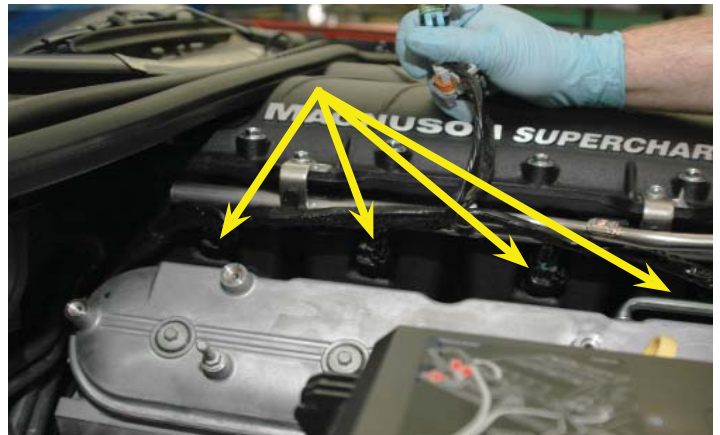

179. Press the OEM injector harness mounting "tree" anchors into the holes of the new fuel rail mounting bracket.

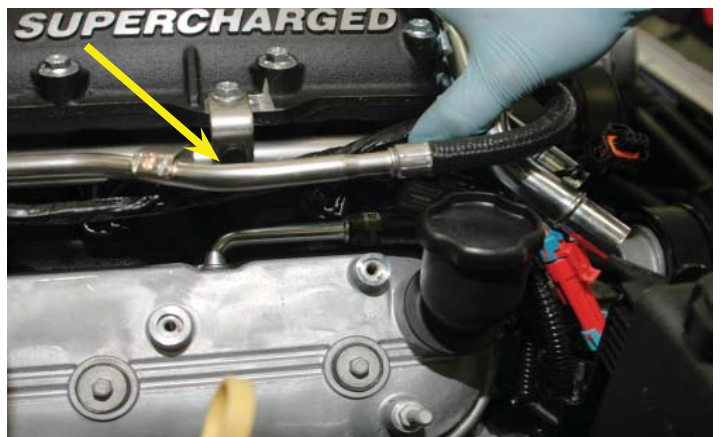

180. Remove the rear coil cover stud on the right side of the engine.



181. Mount the modified coil pack assemblies with the supplied hardware back on the engine. Reuse one of the OEM coil pack bolts with the mounting stud on the front most left side fastener location (closest to the alternator). Mount the right side coil pack mounting bracket incorporating the intercooler reservoir mounting bracket. Torque the mounting bolts down to 106 in-lbs. Verify your torque wrench settings.

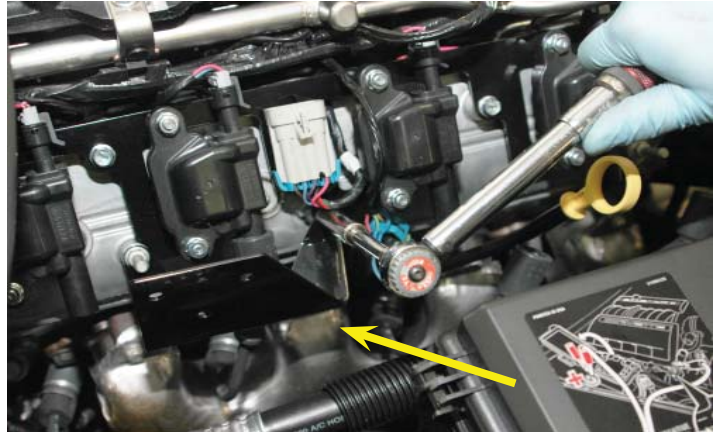

182. If equipped connect the oxygen sensor and coil pack plugs in their original location. Engage the mounting clip in place at the bottom center of the coil pack.



183. Connect all spark plug wires to the coils.

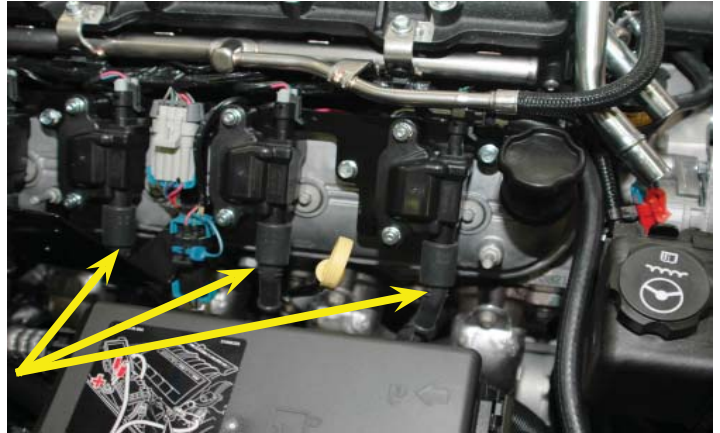

184. Connect the OEM MAP sensor harness to the MAP sensor located on the right side of the supercharger, behind the bypass actuator.



185. On the alternator cable, remove the two rear most harness anchors. There should be one anchor remaining toward the front of the harness.



186. Route the split-loom covered alternator harness back forward toward the alternator. Attach the eye terminal to the alternator using a 13mm wrench. Replace the cover on the terminal. Secure the harness to the sides of the fuel rail, right below the two mounting points with the provided zip-tie "trees". Attach the remaining alternator harness anchor to the front most coil pack bolt (the OEM bolt that you reused in a previous step).



187. Ensure your alternator cable is running below the fuel line. Connect the fuel line to the supercharger fuel rail manifold barb. Test the line by pulling firmly. You should not be able to remove the fuel line without using the fuel line removal tool.



188. Install the OEM fuel line safety clip.



189. Remove the fuel line pressure test cap from the OEM fuel lines and install on the left side fuel rail test port.



190. Plug the supplied brake booster check valve into the stock location on the brake booster canister.



191. Route the brake booster hose forward along the coil pack, connect to the middle barb on the supercharger inlet.



192. NOTE: If your vehicle is equipped with a Vacuum Controlled Exhaust Baffle, connect the free end of the hose to the capped-off hose barb on the left side of the supercharger.

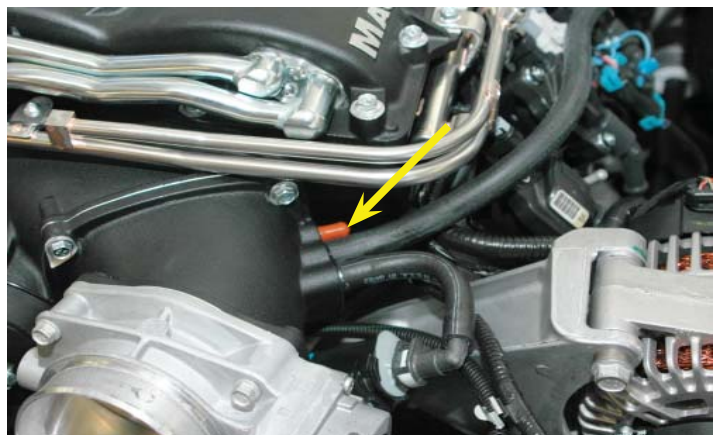

193. Install the short OEM PCV loop hose between the valley cover barb and the adjacent right side lower barb on the supercharger inlet (shown with an arrow). Secure hose with a spring clamp.



194. Use the provided clip to secure the brake booster hose to the fuel line as shown.



195. If the throttle body is contacting the radiator hose loosen the upper radiator hose clamp and twist the hose (clock) to rotate the hose a bit downward. This will add some clearance between the throttle body and the radiator hose. Make sure not to kink the hose anywhere.



## Section 11: Prep and Exposing Areas Behind Body Panels

196. NOTE: If your vehicle has the brake cooling duct exiting toward the rear of the vehicle just after passing through the front splash panel (as shown in this picture), follow this and the next two steps. If your brake cooling duct flattens and turns toward the inside of the wheel well where it is bolted, and points out toward the brake disk, skip to step #168. Remove the eight Push-lock fasteners that secure the front splash panel as shown.



197. Remove the two 7mm bolts and one 10mm bolt that secure the right side end of the spoiler to the splash panel and frame with a socket wrench.



198. Remove the front right side splash panel assembly from the vehicle. You will need to separate the pieces for re-assembly later. Repeat this process to the left side of the vehicle.



199. NOTE: For vehicles with brake cooling ducts bolted to the inside of the fender well (as shown in this picture) follow the next two steps. Remove the two 7mm bolts and one 10mm bolt that secure the right side end of the spoiler to the splash panel and frame with a socket wrench.



200. To remove the fender well splash panel, there are three 7mm bolts on the bottom surface, five T15 Torx screws on the vertical edge to the body connection, and three push rivets at the top of the splash panel that all need to be removed.



201. Remove the front wheel well splash panel from the vehicle and set aside to reinstall in a later step.



202. Use a 10mm wrench to remove the bolt at the inside surface of the fender well by the duct exiting port. Remove the push pin rivet on the front surface of the duct that connects the duct to the air inlet, and pull the brake cooling duct from the vehicle, set aside for later reinstallation.



## Section 12: Preparation and Install of Intercooler Pump and Plumbing.

203. NOTE: All vehicles continue from here. Squeeze the electrical connector to unplug the horn assembly on the right side forward of the wheel well.



204. Use a 10mm wrench to remove the horn assembly from the diagonal fascia sub-frame mounting location.



205. Remove the five 7mm bolts at the tail end of the nose fascia and set aside for later re-installation.



206. NOTE: If your vehicle has the soft rubber air deflector between the nose fascia and the front frame cross member; there will be three 10mm bolts attaching the rear edge of the air deflector to the frame cross member that need to be removed as well (as shown in this picture). Temporarily remove the soft rubber air deflector from the vehicle and set aside for later reinstallation.

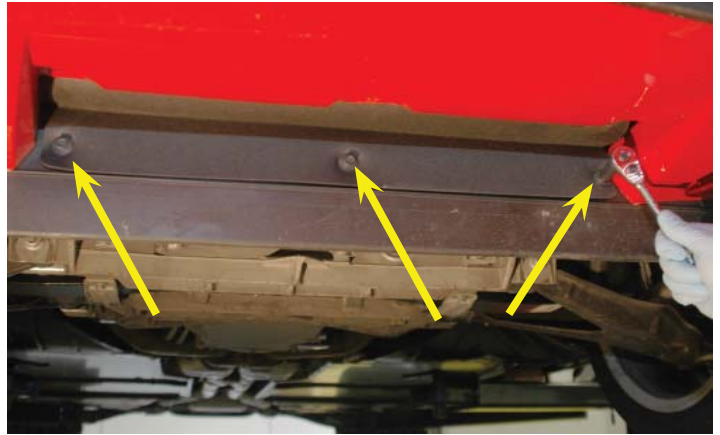

207. The oil cooler will need to be relocated forward 1 inch to make room for the new LTR. You will have to drill new 3/8" hole for four mounts (2 each side) and create 1 1/4" diameter slots for the hardlines to slide forward.



208. Make sure the slots and hose are forward and 1" perpendicular to the radiator. For now leave the cooler loose.





209. Using a 1-1/4" hole saw, create two holes in the right side splash panel one above the other. **The lower hole will use the lower push rivet hole as a center point.** Remove the rivet and create the first 1-1/4" hole. Place the second hole 1" above the first hole, and 3/4" forward away from the heat exchanger (LTR). The hole locations are shown in the next step. Clean up the edges to avoid sharp surfaces.

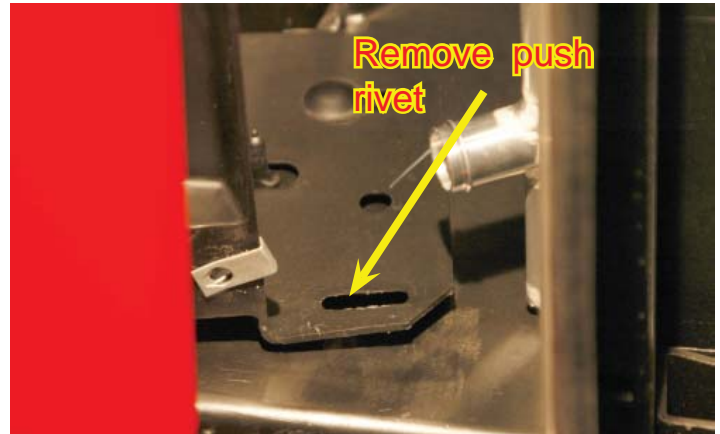

210. Use some sheet metal shears or sharp blade (carefully) to remove the flap of the deflector without disturbing the upper push pin mount. We need some clearance for the next step.

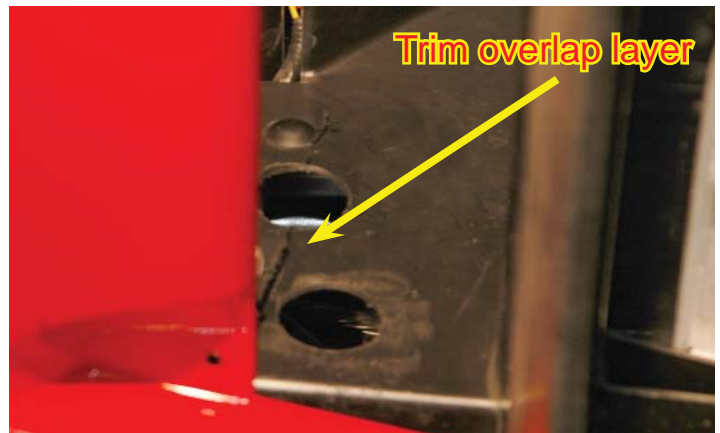

211. Start the Heat exchanger installation by applying the adhesive backed foam strip to the back side of the heat exchanger top and bottom tanks. The back side of the heat exchanger is the side without the two hose connections.



212. Apply a small piece of the foam strip to the Heat Exchanger Retaining Bracket. Trim the foam tape to match the curved section shown. Remove the section marked with the "X".

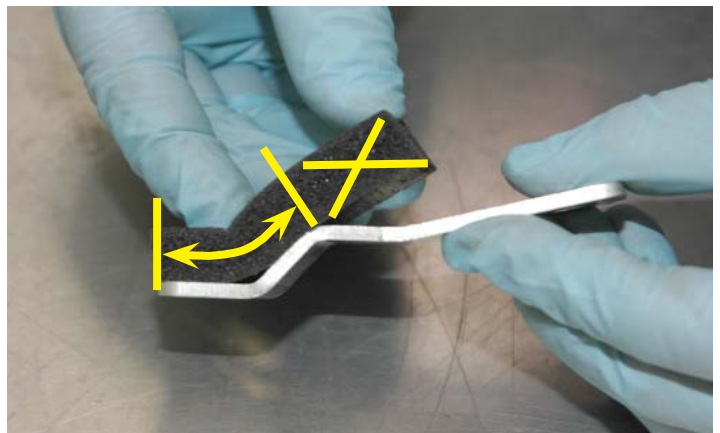

213. Using a 1" hole saw, make a hole in the top of the radiator shroud on the right side. This will create an access hole for the coolant air-bleed valve. The radiator cover is removed in this picture for clarity. Dimensions are to the hole centerline. When drilling the hole, pull plastic away from the A/C condenser to avoid drilling into the condenser.

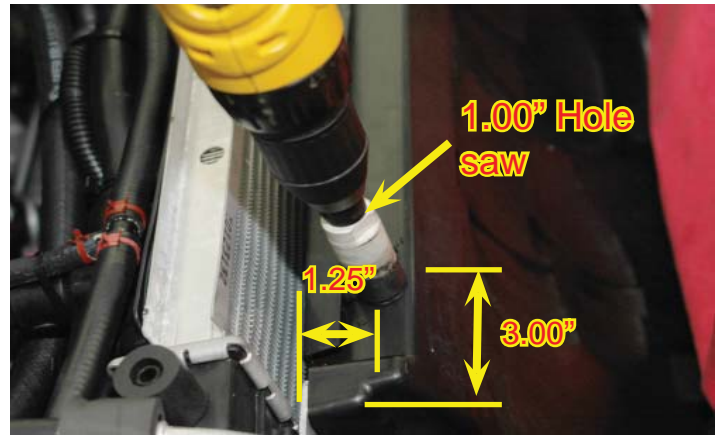

214. Install the heat exchanger by sliding it in front of the radiator. The heat exchanger will sit on the flat area immediately in front of radiator. The foam strips will be on the back side with the hose barbs on the bottom pointing forward. Drill LTR hose holes prior to installing the LTR. You will have to make sure the oil cooler moves forward enough for the LTR to fit behind it. Adjust your relocation holes as necessary.



215. Move the heat exchanger around until the air-bleed valve appears in the newly created hole in the radiator shroud.



216. Secure the oil cooler in place using the factory bolts and supplied washers.

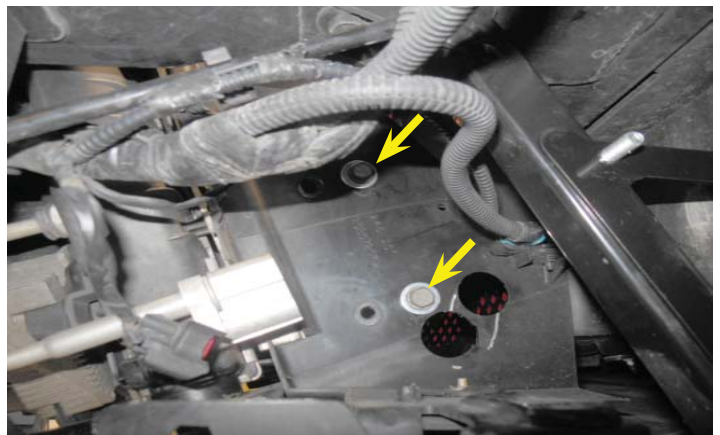

217. **NOTE:** If your vehicle had the soft rubber air deflector removed earlier, this will already be done. If not, then now remove just the center bolt in the spoiler with a 10mm socket wrench as shown.



218. **NOTE:** If your vehicle had the soft rubber air deflector removed earlier, this will be done at a later moment. If not, install the Heat Exchanger retaining bracket with the bolt removed in the previous step. Ensure that the foam pad is contacting the lower tank of the heat exchanger and tighten the bolt securely.

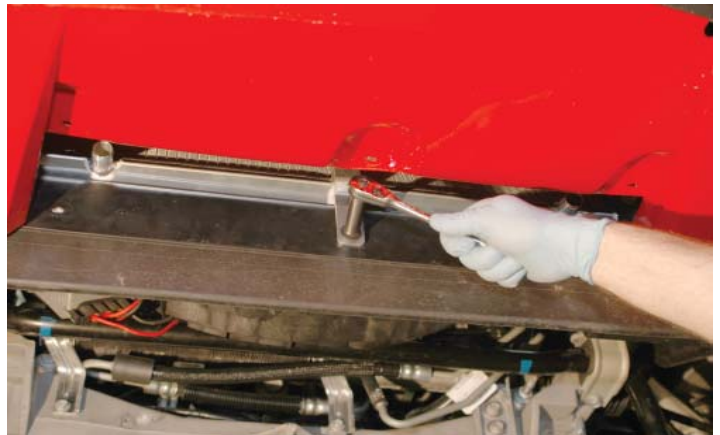

219. Remove the horns from the OEM mounting bracket using a 10mm wrench.



220. Mount the OEM horns to the provided horn mounting bracket using the stock orientation. **NOTE:** There is an "F" stamped in the new bracket indicating the "Front" horn.



221. Slide the provided intercooler pump mounting bracket studs through the lower fascia frame bracing. Secure with the provided nuts on the back-side.

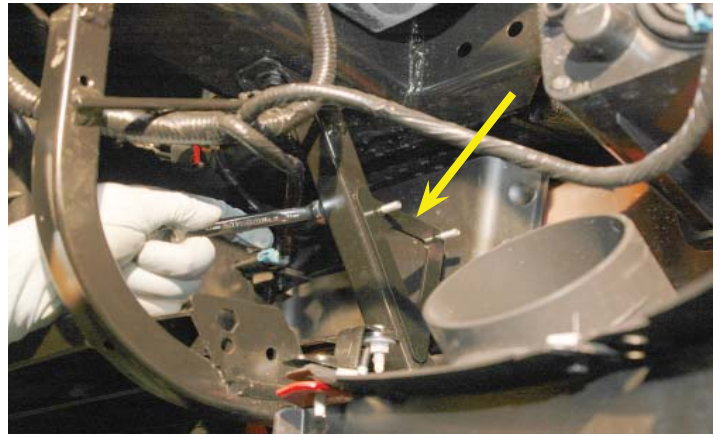

222. Reinstall the horn assembly in the OEM mounting location using the OEM hardware. Tighten firmly. Reconnect the harness wiring to the horns.



223. Mount the two provided Adel clamps to the mounting bracket studs very loosely...just to start the nuts.

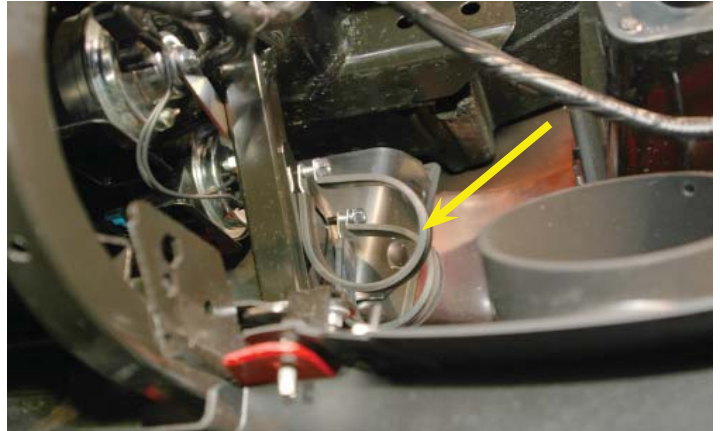

224. Slide pump into Adel clamps.

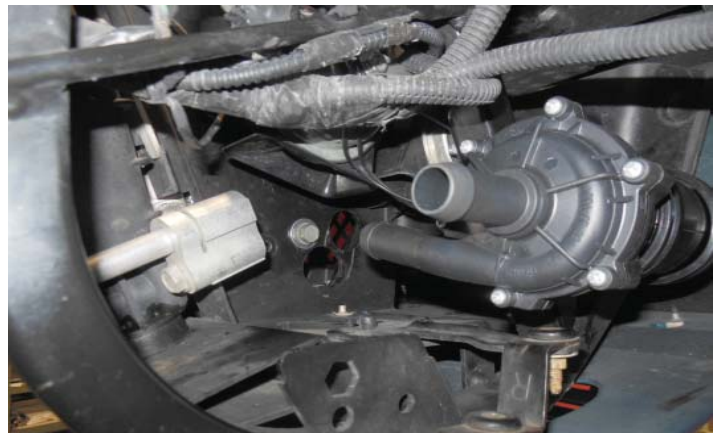

225. Gather the hose shown. This will go from the LTR to the pump. Add steps for pump to LTR hose



226. Run the short section of hose with two bends in it from the last step through upper hole made near the oil cooler on the right side of the vehicle.



227. Attach the section of hose that was routed through the upper hole in the last step to the outlet side of the LTR pump (shown with a yellow arrow) and clamp into place.



228. Connect the short end of the hose you just installed to the left side hose barb on the heat exchanger, secure with a provided spring clamp. Aim clamp tabs downwards.



229. Push the short leg of the provided 3" x 60"x 3/4" 90° elbow hose with the quick disconnect end through the remaining (lower) hole by the pump. Feed the hose from the horn side toward the heat exchanger in the front of the vehicle. Connect the short leg to the right side hose barb on the heat exchanger with a provided clamp.



230. Route this hose below the pump, behind the radiator and into the engine compartment.



231. Route the "Y" hose up (with the two hose split going up) and into the engine compartment. Connect the free end with the 90° elbow to the intercooler pump inlet hose barb with a provided clamp. Make sure the hose is not kinked near the frame.

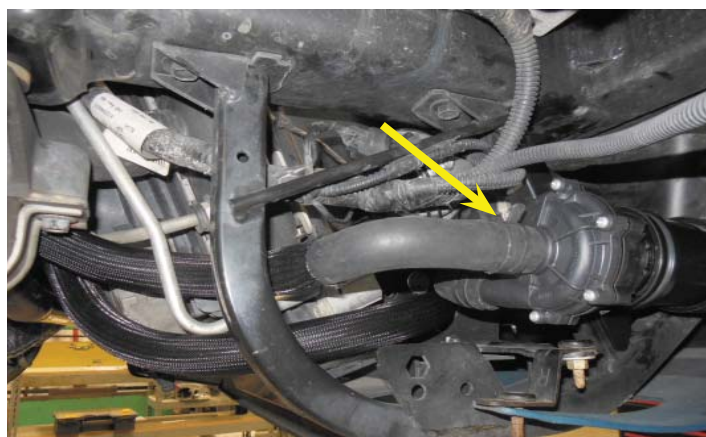

232. Connect the right side heat exchanger hose barb quick disconnect to the inside barb of the intercooler hard line. It will "click" into place.



233. Connect the quick disconnect section of the “Y” hose just installed to the right side intercooler hard line hose barb. It will “click” into place. Route the remaining hose from the “Y” as shown under the P/S reservoir.



234. Attach the intercooler reservoir to the mounted bracket using the supplied 10mm bolts, tighten firmly.



235. Install the supplied “cap” on the upper spigot with a provided worm gear clamp.



236. Connect the free end of the “Y” hose to the lower hose barb on the intercooler reservoir with a worm gear clamp. It’s important to use only worm gear clamps on the intercooler reservoir.

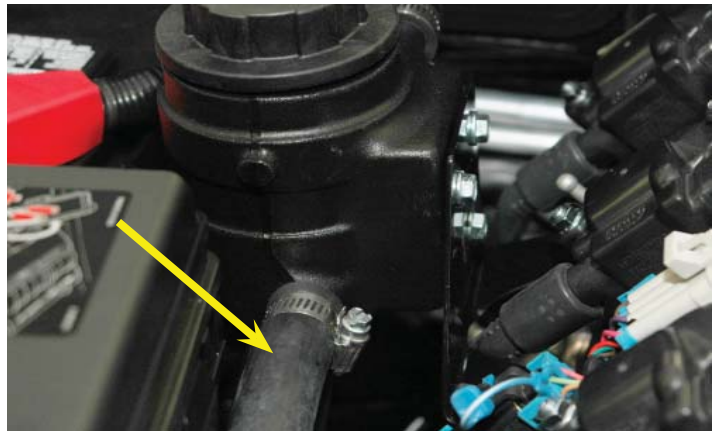

## Section 13: Intercooler Wiring

237. Remove the forward upper hood latch bracket bolt on the right side adjacent to the fuse center. Replace the bolt incorporating the supplied intercooler relay mounting bracket.



238. Here is the intercooler pump wiring harness components. Install the supplied fuse into the fuse holder and replace the cover.



239. Remove the yellow wire from the relay of the intercooler pump harness.

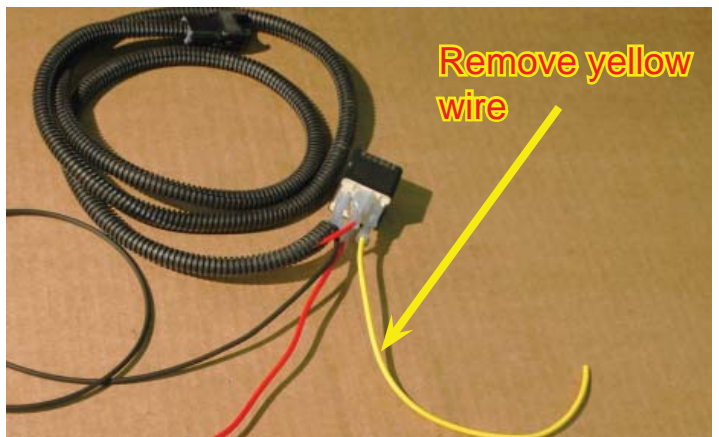

240. Route the remaining wire from the EVAP Solenoid harness installed near the alternator bracket, under the fuse box over and up to connect to the post of the relay vacated by the yellow wire.





241. Mount the relay to the rear mounting stud of the relay bracket using the supplied nut. Mount the fuse holder to the remaining stud on the relay bracket with the provided nut.

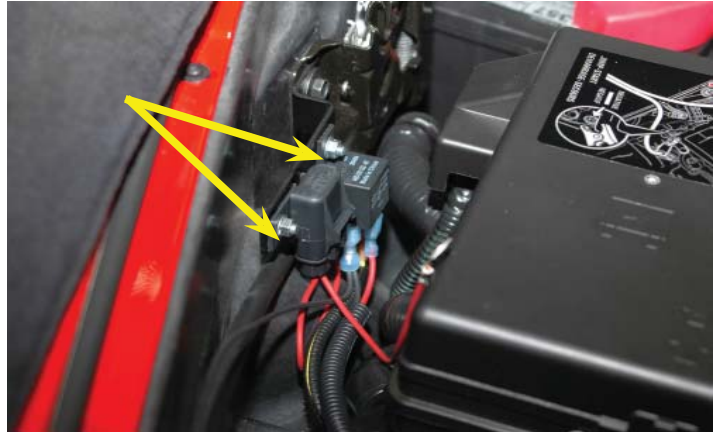

242. Use a 13mm wrench to remove the nut on the positive terminal and replace the nut incorporating the large "eye" terminal of the red wire from the fuse holder of the intercooler wiring harness and secure using the 13mm wrench. Cover the wire with the supplied split loom.



243. Route the black ground wire from the intercooler pump harness forward along the frame rail. Remove the nut from the ground post by the right side hood shock mount near the radiator using a 10mm wrench, replace the nut incorporating the black ground wire and tighten with a 10mm wrench.



244. Route the plug end of the intercooler pump harness forward and down to the intercooler pump and connect to the terminal near the clamp on the forward end of the pump as shown. Secure the harness with provided zip ties along the way.



245. Add zip tie and make sure hoses are not kinked.

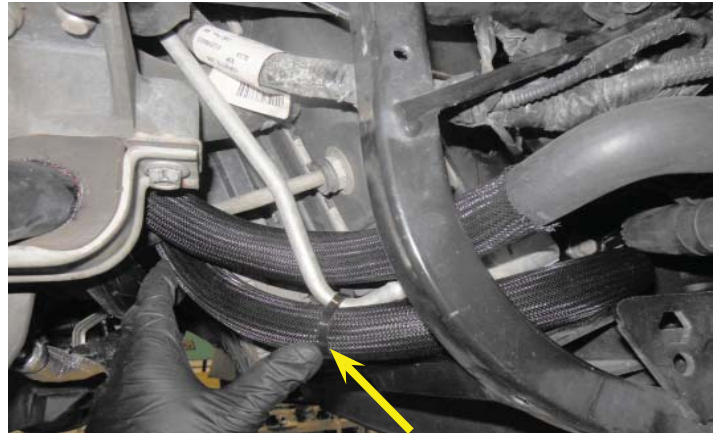

246. Use a provided zip-tie "tree" and insert in the power steering bracket tab. Loop around both intercooler hoses. Do not over-tighten, you do NOT want to pinch the hoses, just secure them from movement. Wrap barbed tie around the closest hose then wrap a second tie around both.



## Section 14: Fuel Pump Booster Installation

247. Install the Fuel Pump Booster bracket shown near the oil sump tank using a 10 mm socket using the bolt locations shown.



248. Here are the Fuel Pump Booster components.



249. Open the Fuse/Relay center cover. Remove the positive (+) battery cable connection using a 13mm socket wrench. Use a 7mm socket to release the four bolts in the top of the Fuse/Relay center. These bolts cannot be removed; you will feel when the bolts no longer engage their threads. Now press the bolts down to disconnect the four wiring blocks from the bottom of the Fuse/Relay center. Detach the Fuse/Relay center from its base by gently prying open the four retaining clips shown here. Pull up firmly on the Fuse/Relay center to expose the four wiring blocks located in the base.

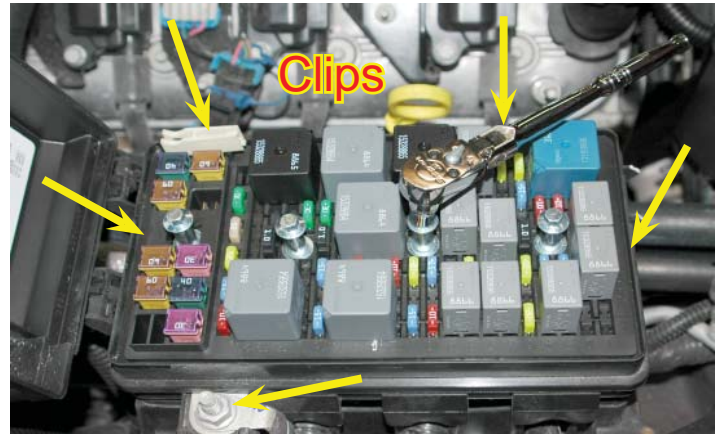

250. The four wiring blocks are different colors, light-gray, white, dark-gray, and black. Lift the DARK-GRAY block from the base.

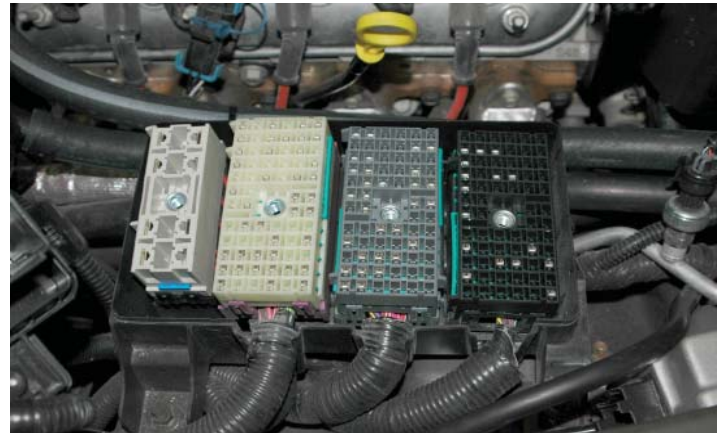

251. Gently remove the wire cover from the bottom of the DARK-GRAY wiring block by prying up on the clips that retain the cover on each end. This will expose the wire connections on the bottom of the block.

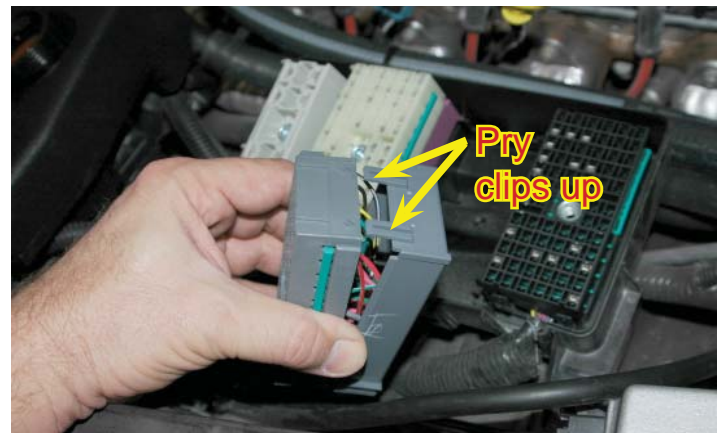

252. Here is the DARK-GRAY wiring block with the bottom cover removed showing the wiring. Note: The wire connections are lettered across the top and numbered down the side. Locate the GRAY wire in the A7 location. This is the wire we will be making connections to.

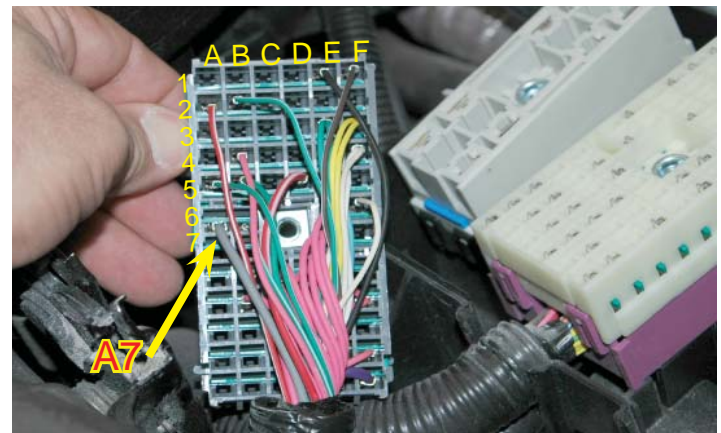

253. Locate the GRAY wire in the A7 location. Cut the wire approximately 1-1/2" from the block and strip the insulation back 1/4" from both ends. Locate the RED WIRE WITH THE FUSE HOLDER from the Fuel Pump Booster and connect it to the end of the GRAY wire on the DARK-GRAY wiring block with a crimp-shrink connector.

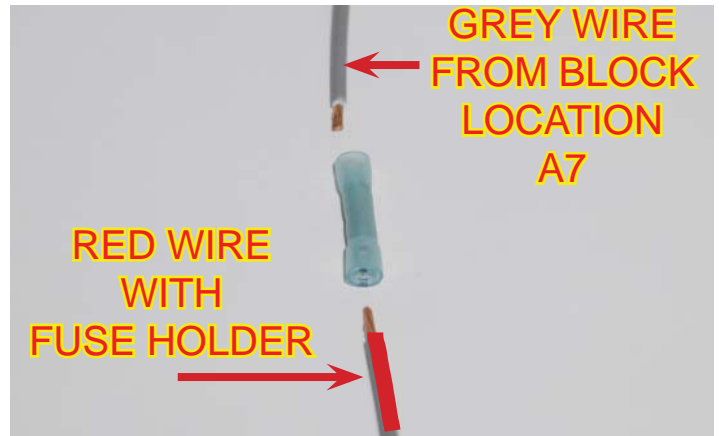

254. Install the crimp-shrink connector by inserting the stripped ends into the connector and crimp them securely. Using a heat gun or blow-dryer set on high, shrink the plastic covering of the connector until the plastic covering has shrunk tightly around the wires. **Crimping the connector alone is not enough; you must shrink the plastic covering!**

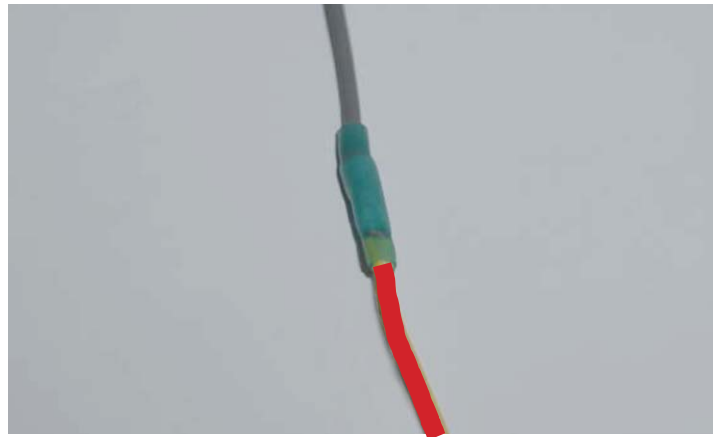

255. Use the same process to connect the RED WIRE WITHOUT THE FUSE HOLDER from the Fuel Pump Booster to the remaining end of the GRAY wire going into the wiring harness with a crimp-shrink connector.

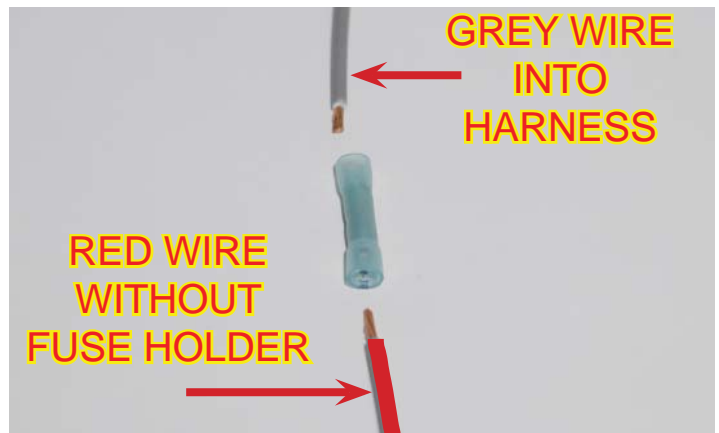

256. Locate the BLACK WIRE from the Fuel Pump Booster and strip the insulation back 1/4" from the end. Install the crimp-shrink "EYE" connector to the end of the Black Wire, crimp and shrink securely using a heat gun or hair dryer set on high.



257. Route the BLACK wire with the “eye” connectors from the Fuel Pump Booster down to the ground terminal located directly below the Fuse/Relay center base on the frame rail. Remove the nut of the ground terminal using a 10mm wrench, place the “eye” connector on the ground terminal and re-install the nut securely.

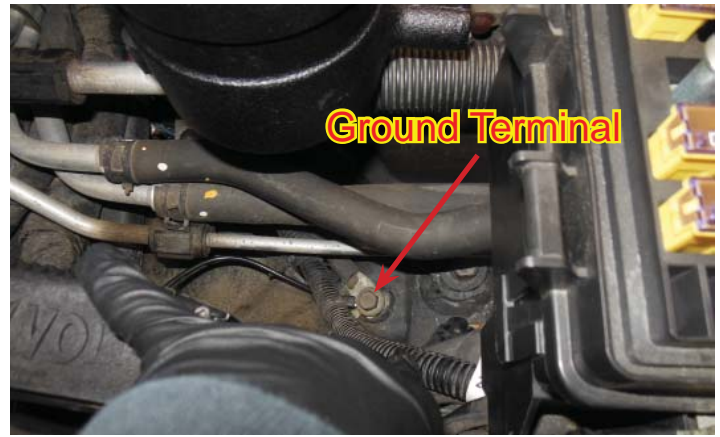

258. Once the electrical connections are made, re-connect the wiring blocks to the bottom of the Fuse/Relay center by carefully tightening the four bolts with a 7mm socket. Pass the new wires out of the base along the harness from the DARK GRAY wiring block. Snap the Fuse/Relay center back into its original location on the base.



259. Replace the Fuse/Relay center cover.



260. Use supplied lock nuts to attach booster to bracket.



261. Using the hose supplied, connect one end of the hose to the pressure port barb, and route the other end to the Fuel Pump Booster by the Fuse/Relay center. **It is critical that this hose does not kink. Make sure it is routed properly. Double check your work.**



262. Connect the remaining end of the hose to the Fuel Pump Booster pressure switch. Secure the hose out of the way using the tie-wraps supplied. **Do not crush hose.**



## Section 14: Air Box Installation

263. Replace the radiator cover using the OEM hardware.



264. Remove the three grommet-post-push pin rivets from the radiator cover by prying the center "nail" up after pulling the grommets off.



265. Place a strip of light colored tape on the left side of the upper grooves in the splash shield/air deflector in front of the radiator/heat exchanger as shown.



266. Assemble the new air box using the provided “bellows” on the throttle body end, and the provided screws and spacers with the provided air filter on the intake end. The spacers go between the plastic air filter retainer and the air box. Where the bellows attaches to the air box, rotate the clamp so the screw is on the bottom. Tighten the clamp securing the bellows to the air box. NOTE: Trim off the un-necessary tab of the bellows with a sharp knife or pair of dykes.

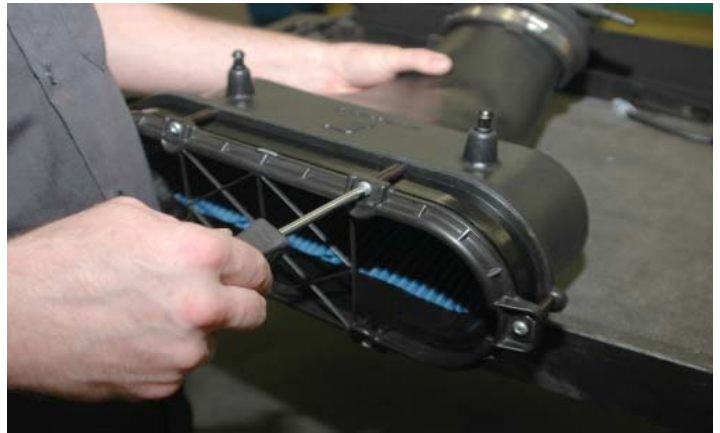

267. Insert two of the push pin rivets into the existing ¼” holes in the bottom of the new air-box stand-off mounts. Push the “nails” back in locking the rivets in place.



268. Push the bellows and air box assembly onto the throttle body and loosely tighten the clamp.



269. Use a sharp pencil or pen to mark around the strike of the push pin rivet mounting posts onto the light tape (you placed on the splash shield/air deflector earlier). Be careful to not move the air box between marking each side of the air box push-pin mounting posts or installation will be difficult.



270. Remove the bellows and air box assembly, use an awl or center punch to mark through the tape onto the splash shield/air deflector.



271. Use a 5/8" drill with an assistant holding a backing board behind the splash shield/air deflector to drill the two holes you just marked. NOTE: You need to be careful, because a standard bit will bite through the plastic and pull the drill motor and bit into the heat exchanger close behind the splash shield. A Forstner bit or hole-saw may work, but in any case, use extreme care to not damage the heat exchanger and radiator.



272. Insert two of the grommets you removed from the OE air box into the 5/8" holes you just drilled. NOTE: Sometimes the grommets will stick to the pin when you pull the air box up.





273. Attach the bellows of the air box assembly back onto the throttle body and tighten using a flathead screwdriver or 8mm nut driver. Tighten firmly in position. Align the pins on the bottom of the air box with the grommets and press the air box down into the grommets anchoring the assembly in position.



## Section 15: Fascia Reinstallation, Coolant Fill and Testing

274. Remove the MAF sensor from the OEM airbox and install in the left side slot of the new airbox. Use the two provided black washers to space the MAF Sensor away from the air box.



275. Install the provided fresh air hose between the sump tank and air duct. The 45° end goes to the sump tank, and the blue clip end goes to the air duct. This hose is highlighted in red. Route as shown.



276. Connect the supplied IAT/MAF extension harness to the factory harness connector. Route the IAT plug over to and connect to the IAT Sensor on the left side of the supercharger assembly.



277. Connect the MAF plug extension to the MAF sensor you installed earlier in the new air tube.



278. NOTE: If your brake cooling duct flattens and turns toward the inside of the wheel well where it is bolted, and points out toward the brake disk, skip this and the next step. For other vehicles, replace the brake duct and splash shield using all the stock hardware.



279. Reattach the spoiler and nose fascia sections using all the original hardware and locations. This includes push pin rivets and bolts.



280. NOTE: If your brake cooling duct flattens and turns toward the inside of the wheel well, re-attach the inlet end using the OEM push rivet, and re-attach the discharge end back in its stock location with the OEM bolt.

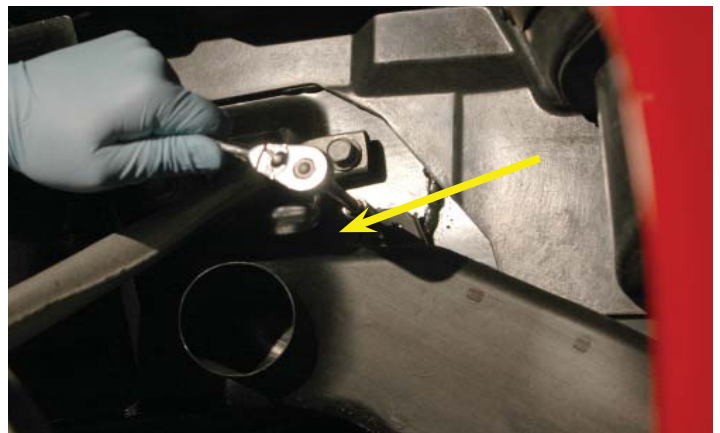

281. Re-attach the nose fascia and spoiler at the bottom using all the stock fasteners, tighten securely.



282. NOTE: For vehicles with the soft rubber air deflector follow the next four steps. If your nose fascia was attached earlier, skip these steps. Use the three stock 7mm bolts to secure the center nose fascia up to the sub-frame mounting locations, incorporating the soft rubber air deflector removed earlier as shown.



283. Re-attach the underside ends of the nose fascia as shown using the two outside 7mm bolts, tighten securely.



284. This shows the center spoiler mounting hole which will be the location of the heat exchanger mounting bracket. We will incorporate this bracket behind of the back side of the soft rubber air deflector. The foam is designed to press against the heat exchanger tank. Rotate the bracket up to the vertical position behind the soft rubber air deflector. Ensure that it remains vertical and engages the bottom of the heat exchanger and then tighten in place with one of the 10mm bolts removed earlier.



285. Use the remaining two 10mm bolts to attach the frame end of the soft rubber air deflector incorporating the heat exchanger mounting bracket in the center hole. Ensure that the foam pad of the bracket is contacting the lower tank of the heat exchanger and tighten the bolt securely.

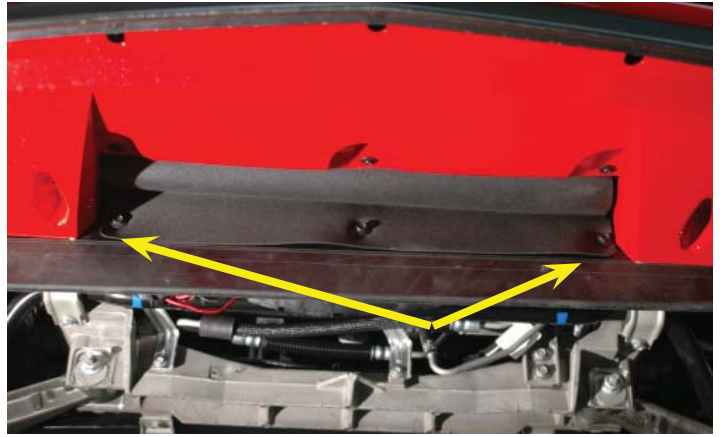

286. Re-install the road wheel and torque the lug nuts to 110 Ft-Lbs.



287. Fill the radiator reservoir with a GM approved coolant mixture. If you saved the fluid you drained from your radiator you can filter it and use it to refill your radiator system.



288. Fill the intercooler reservoir with a GM approved coolant mixture. Fill the reservoir until the fluid level comes to about one and a quarter inch from the top edge of the filler neck.



289. Fill the power steering reservoir with approved power steering fluid.



290. Affix the Premium Fuel Only decal on the inside of the fuel fill door.



291. Affix the OBDII port cover on the OBDII port at the left side below the dash. Clip the cover ring on an adjacent wire to keep it local.



292. Reconnect the battery negative (-) terminal, tighten with 10mm wrench.



293. Have someone turn the ignition switch to the accessory mode to trigger the pump on for 5 -10 seconds. **Do not start the vehicle.** This will circulate the fluid. Check for fuel leaks at this time too. Fill the intercooler reservoir while the pump circulates. Repeat this process until the system is full. When the system is full you can use a straight blade screwdriver to open the bleed valve and let any trapped air escape from the intercooler system. Some coolant will be lost when bleeding the system. Top off system after bleeding. Check for coolant leaks throughout the system.

**Don't forget to follow step #1 to tune your engine prior to starting it.**

294. Start the engine and let it idle for 5-10 seconds. Check for fuel leaks and proper belt alignment. If there are no fuel leaks and belt alignment is good then start the vehicle again. Let idle for 3-5 minutes, bringing the engine to operating temperature. Check the radiator, intercooler, and power steering fluid levels again. Fill as necessary. If the intercooler level has dropped open the LTR bleeder valve again to purge any residual air trapped in the system, and top of the reservoir until stabilized. .

295. Re-install the OEM hood using the original hardware and tighten securely in place. NOTE: You will most likely need to adjust the alignment. To aid in alignment, try to align the washers with their original wear marks on the hood.

296. Carefully remove the factory hood insulation mat using a flat bar or flathead screwdriver to pry the push pins out. If you installed the sub frame spacers earlier on you can leave your liner attached.



297. Test drive vehicle for the first few miles under normal driving conditions, listen for any noises, vibrations, engine miss fire or anything that does not seem normal. The supercharger does have a slight whining noise under boost conditions, which is normal. After the initial test drive gradually work the vehicle to wide open throttle runs, listen for any engine detonation (pinging). If engine detonation is present let up on the throttle immediately. Most detonation is caused by low octane gasoline still in the tank. Premium gasoline fuel (91 octane or better) must be used! Recheck your radiator and intercooler fluid levels. Fill as necessary.

## Diagram A

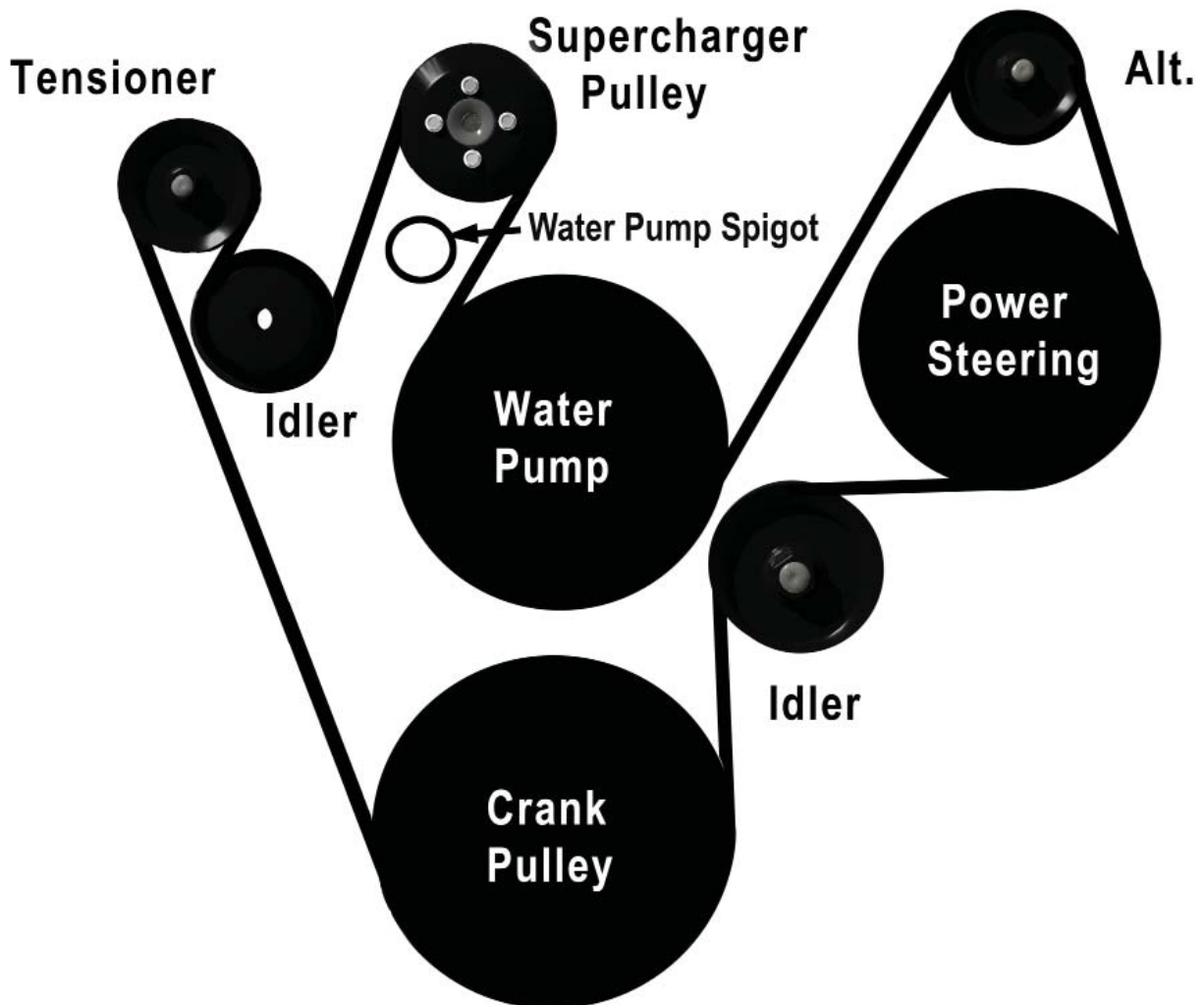

**2006-2008 C6 LS7 Corvette  
Drive Belt Routing Diagram  
(Gates Belt #K061005)**

## Diagram B

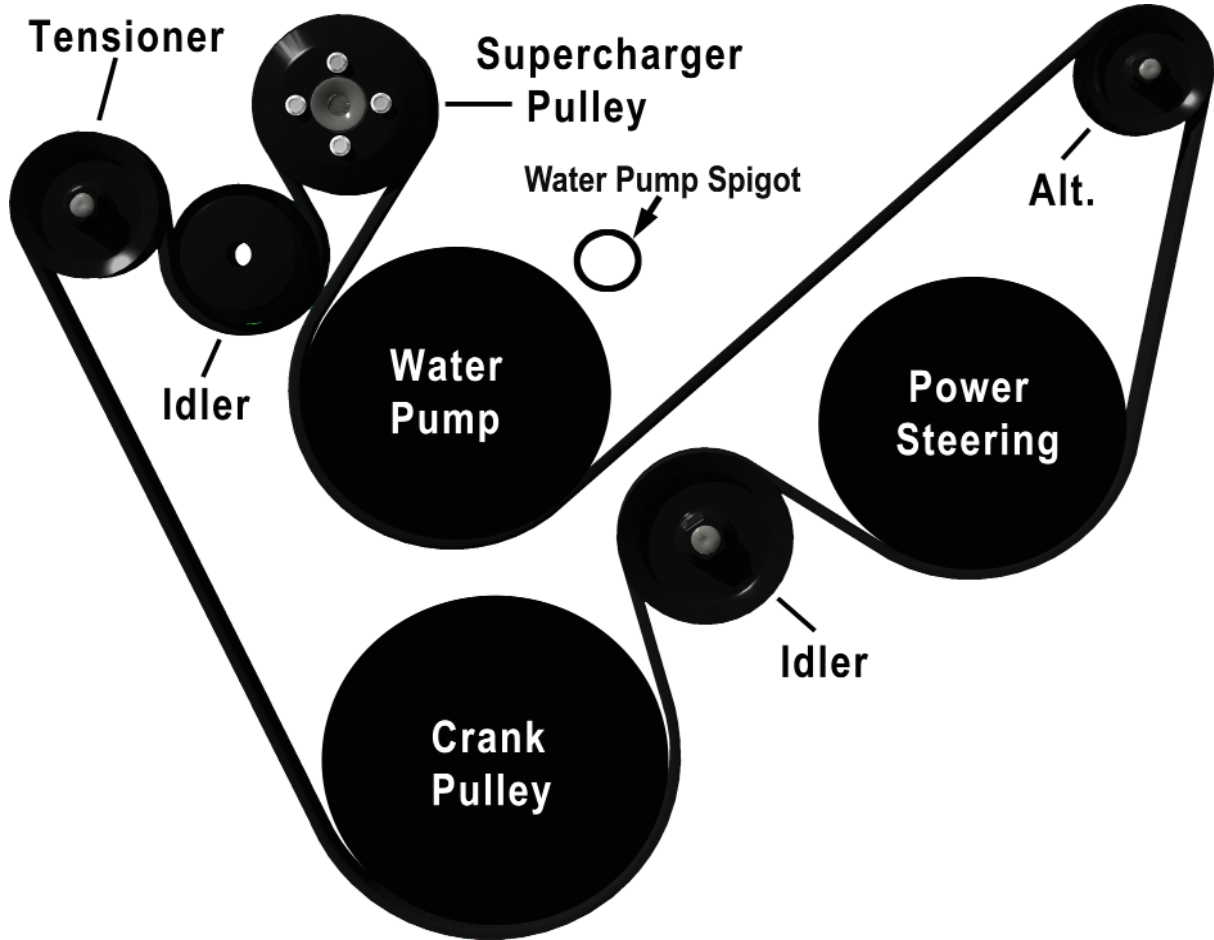

**2009-2013 C6 LS7 Corvette  
Drive Belt Routing Diagram  
(Gates Belt #K060980)**



## Diagram C

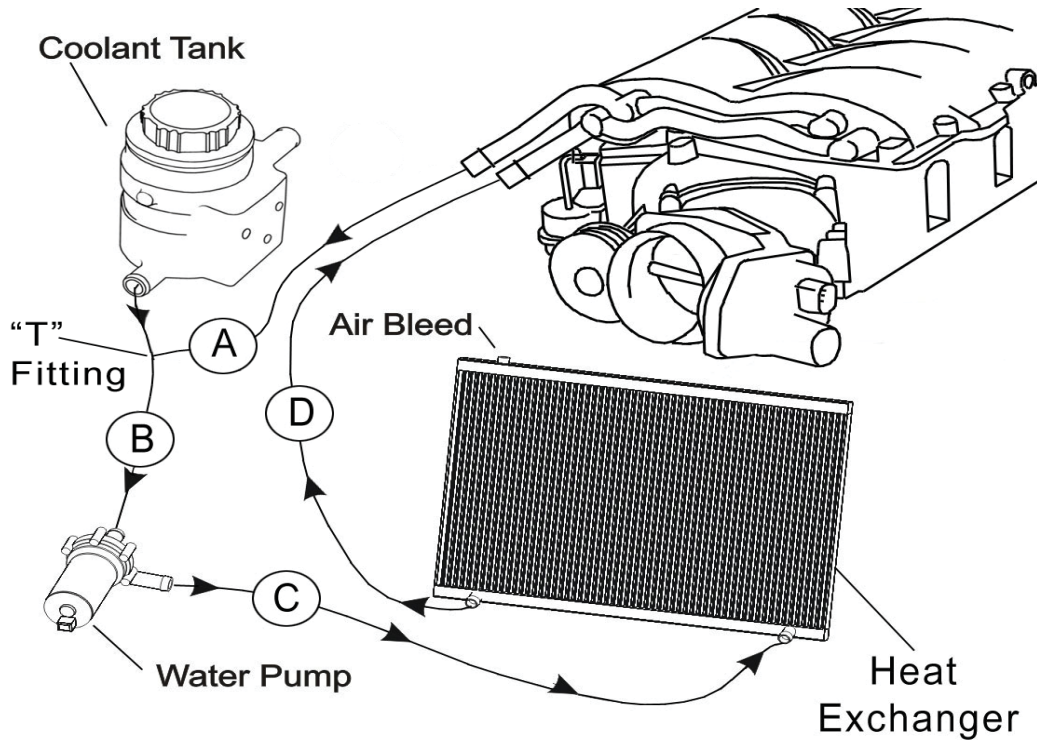

Intercooler Routing Diagram  
C6 Corvette Heartbeat

**NOTE: YOU MUST USE GM SPECIFIED COOLANT,  
AND DISTILLED WATER ONLY!**

## Diagram D

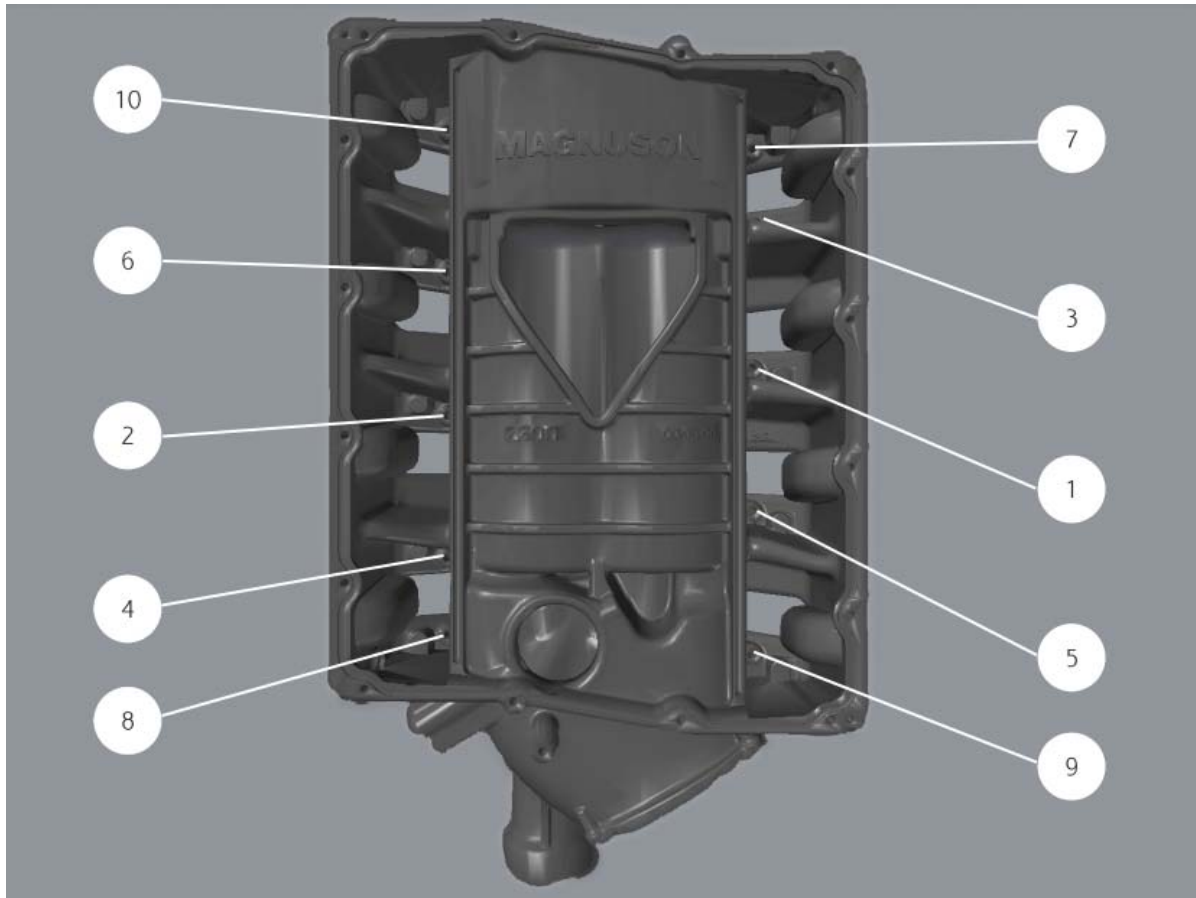

### **Supercharger Torque Sequence**

# Diagram E

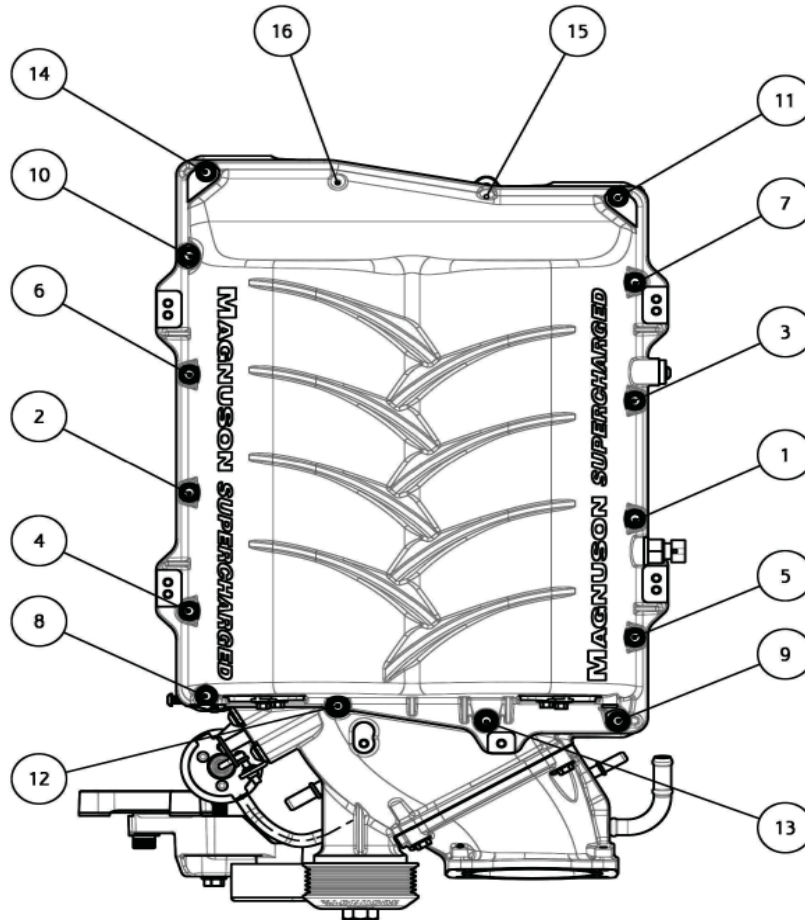

## **Lid Torque Sequence**

Fastener Length

20mm: 9, 10, 11, 12, 13, 14 (9-14)

25mm: 15, 16

50mm: 1, 2, 3, 4, 5, 6, 7 (1-7)

60mm: 8



If you have questions about your vehicles performance, please check with your installation facility.



Please enjoy your "Magnuson Super-Charged" performance responsibly.

**Use only premium gasoline fuel, 91 octane or better.**

**MAGNUSON**  
*SUPERCHARGERS*