

# MAGNUSON

## SUPERCHARGERS

HeartBeat Installation Instructions for:  
**INTERCOOLED SUPERCHARGER SYSTEM**  
2013-2015 LS3/L99 Chevrolet Camaro



Step-by-step instructions for installing the best in supercharger systems.

**\* PREMIUM GASOLINE FUEL REQUIRED \***

**ATTENTION!**

Your **MAGNUSON SUPERCHARGER** kit is sensitive to corrosion!

Use only the vehicle manufacturer recommended coolant for your engine in the intercooler system as well.



Magnuson Products LLC  
1990 Knoll Drive, Bldg A, Ventura, CA. 93003  
(805) 642-8833  
[magnusonsuperchargers.com](http://magnusonsuperchargers.com)

# INSTALLATION MANUAL

## Magnuson SuperCharger GM 6.2L Engine 2013-2015 LS3/L99 Chevrolet Camaro

Please take a few moments to review this manual thoroughly before you begin work. Make a quick parts check to make certain your kit is complete (see shipper parts list in this package). If you discover shipping damage or shortage, please call our office immediately. Take a look at exactly what you are going to need in terms of tools, time, and experience. Review our limited warranty with care. When unpacking the supercharger kit DO NOT lift the supercharger assembly by the black plastic bypass actuator. This is pre-set from the factory and can be altered if used as a lifting point!

Caution: Relieve the fuel system pressure before servicing fuel system components in order to reduce the risk of fire and personal injury. After relieving the system pressure, a small amount of fuel may be released when servicing the fuel lines or connections. In order to reduce the risk of personal injury, cover the regulator and fuel line fittings with a shop towel before disconnecting. This will catch any fuel that may leak out. Place the towel in an approved container when the job is complete.

**Use only premium gasoline fuel, 91 octane or better.**

Magnuson SuperCharger systems are manufactured to produce about 20 RWHP per pound of boost at sea level. High altitudes will produce different numbers.

Our Magnuson SuperCharger kits are designed for engines in good mechanical condition only. Installation on high mileage or damaged engines is not recommended and may result in engine failure, for which we are not responsible. Magnuson Products is not responsible for the engine or consequential damages.

**Magnuson Products supercharger kits are designed for use on stock vehicles. To that end, the alteration or modification of the fuel system, drive train, engine, and/or supercharger outside of stock parameters in any way can result in engine damage or failure for which Magnuson Products is NOT responsible and will void Magnuson Products warranty and CARB certification. Aftermarket engine recalibration devices that modify fuel and spark curve (including, but not limited to programmers) are not recommended and may cause engine damage or failure. Use of non-Magnuson Products approved programming will void all warranties. If you have any questions, call us.**

A new GM fuel filter is recommended at the time of supercharger installation  
Stock spark plugs and stock plug gap are recommended  
Drive belt = Gates# K061005

### Tools Required:

Metric wrench set  
1/4" - 3/8" and 1/2" drive metric socket set with 22mm and 24mm(Standard & Deep)  
3/8" and 1/2" drive Foot pound and inch pound torque wrenches  
1/2" breaker  
Metric Allen socket set with 3/8" drive  
Phillips, flat and Torx head screwdrivers  
Fuel line quick disconnect tools (included in kit)  
Small or angled 3/8" drill motor  
1/2" Impact wrench  
Drain pan and funnel  
Hose cutters and hose clamp pliers  
Safety glasses  
Shop vacuum cleaner  
Pry tool and nut driver

Contact information:  
Magnuson Products LLC  
1990 Knoll Drive, Bldg A  
Ventura, CA 93003  
Sales/Tech support: 805-642-8833  
Websites:  
[www.magnusonsuperchargers.com](http://www.magnusonsuperchargers.com)  
Email:  
[sales@magnusonproducts.com](mailto:sales@magnusonproducts.com)

# Table of Contents

<b>Section 1: Tuning Your Vehicle Computer and Initial Steps</b>	<b>4</b>
<b>Section 2: Intake Plenum, PCV, EVAP, and Fuel Line Removal</b>	<b>7</b>
<b>Section 3: Coil Pack, and Manifold Removal</b>	<b>12</b>
<b>Section 4: Coolant Line and Air Box Removal</b>	<b>17</b>
<b>Section 5: Crank Pulley Pinning</b>	<b>20</b>
<b>Section 6: Idler Pulley Replacement</b>	<b>23</b>
<b>Section 7: Steam Pipe, and Coil Pack Replacement</b>	<b>25</b>
<b>Section 8: EVAP Solenoid, and Manifold Parts Removal</b>	<b>30</b>
<b>Section 9: Fuel Rail Preparation, and Supercharger Install</b>	<b>33</b>
<b>Section 10: Belt, Radiator, and Throttle Body Installation</b>	<b>45</b>
<b>Section 11: Hose Line and Electrical Connections</b>	<b>48</b>
<b>Section 12: Front Fascia Removal</b>	<b>55</b>
<b>Section 13: Low Temperature Radiator (LTR) Installation</b>	<b>58</b>
<b>Section 14: Body Panel Installation, and Final Inspection</b>	<b>68</b>
<b>Appendix</b>	<b>71</b>

NOTE: This instruction manual follows the process we used to complete this installation on our test vehicle. This does not imply there aren't alternate approaches.

**\* PLEASE PAY ATTENTION TO THE STEPS IN THIS INSTRUCTION MANUAL. ENGINE DAMAGE CAN OCCUR IF YOU DO NOT FOLLOW THE INSTRUCTIONS. \***

**NOTE: For the purpose of these instructions all references to left or right side are assumed to be as indicated from the seated position in the driver seat of the vehicle.**

## Section 1: Tuning Your Vehicle Computer and Initial Steps

1. The first step is to setup your vehicle ECM/TCM control modules. Follow the instructions in your SCT tuner manual to update your Camaro to function with the Magnuson Supercharger system.



2. Your Intercooler system is sensitive to corrosion. It's very important to use the OEM recommended coolant mixture in your supercharger system as well.



3. Your system requires the use of minimum 91 Octane gasoline fuel. This system is not compatible with E85 fuel.

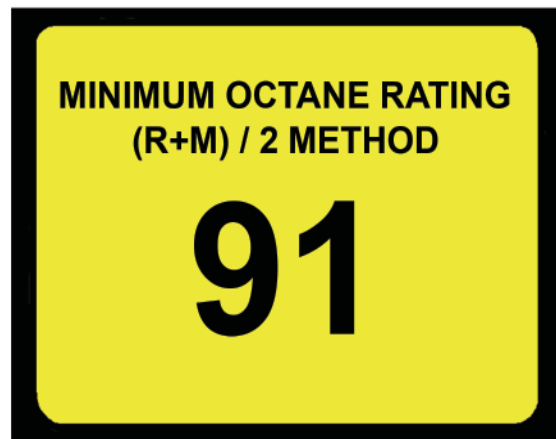



4. Open the trunk and lift up the floor mat. Unscrew the cap nut holding the floor panel in place and set the panel aside for later reinstall.



5. Remove the protective cover underneath the floor panel.



6. Your battery is now exposed. Disconnect the battery negative terminal using a 10mm wrench. Cap or cover the terminal to protect against accidental contact with the battery post.



**Make sure your vehicle has cooled down before proceeding.**

7. Remove the radiator fill cap.



8. From below the vehicle on the left hand side, loosen the petcock drain to allow the radiator to release the coolant. Collect in a clean pan for refilling later on. Set aside in a safe place where it won't be contaminated. When draining is completed, tighten the petcock valve and replace the radiator cap.



9. Use a 13mm wrench to remove the strut tower brace, if equipped, at the suspension towers. There are two bolts on each side. Set the strut tower brace aside.



10. Disconnect the PCV tube at the oil separator if equipped.



11. Remove the oil fill cap, or the oil separator if equipped.





## Section 2: Intake Plenum, PCV, EVAP, and Fuel Line Removal

12. Lift up on the front edge of the engine cover to disconnect the cover from the mounting posts.



13. Replace the oil fill cap. If vehicle was equipped with oil-separator, cap or cover the fill neck. The separator will be installed in a later step.



14. Remove vacuum line release tab shown with a screwdriver, and disconnect the line.



15. Use an 8 mm nut driver or flat head screwdriver to loosen the clamps holding the bellows to the air box, and the air supply plenum to the throttle body. Pull these connections free.



16. Lift up and pull the air supply plenum out of the engine compartment. Set aside in a safe place.



17. Disconnect the EVAP tube looping over the throttle body from the right hand side of the engine to the rear of the left hand side at the throttle body.



18. Disconnect the other end of the tube at the EVAP Solenoid by pressing the white release tabs and pulling free.



19. Disconnect the electrical plug on the EVAP Solenoid.





20. Disconnect the remaining tube from the EVAP Solenoid.

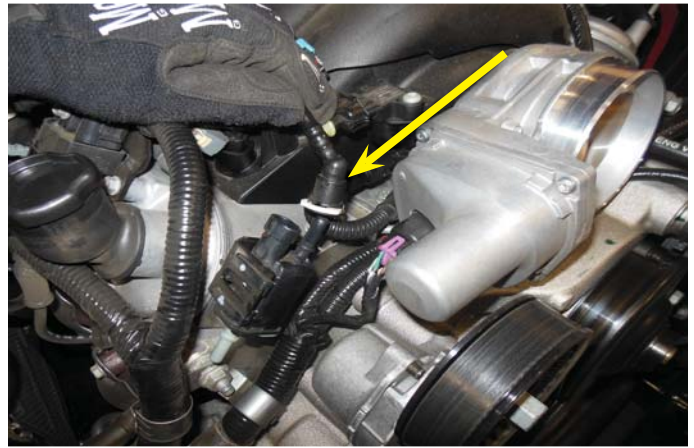

21. Use the supplied fuel line removal tool to disconnect the EVAP connection next to the fuel line on the right hand side of the engine behind the heat shield. First, push the connection onto the hard line barb a bit, then press the fuel line removal tool into the fitting to release the retaining ring. Now pull the EVAP line off of the hard line barb.

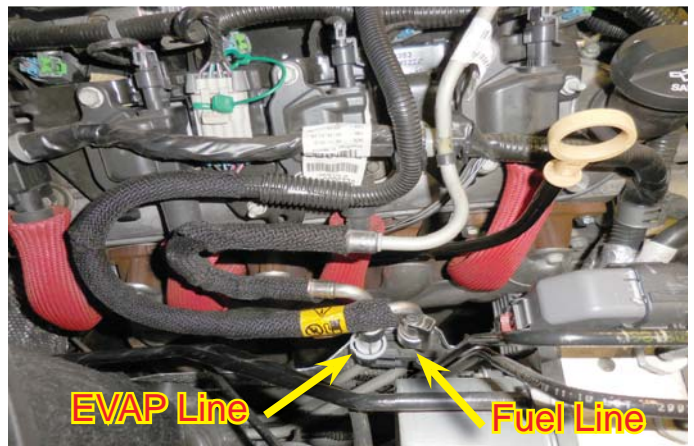

22. Remove the fuel tank cap to relieve residual pressure on the fuel system.



23. Use a 10 mm socket wrench to remove the four bolts holding the fuel rail to the intake manifold.



24. Place some shop towels below the fuel line connection on the left hand side of the engine to catch residual fuel.



25. Pry up on the safety clip to remove the fuel line clip from the fuel line/fuel manifold.



26. Push the fuel line onto the manifold barb a bit and press the fuel line removal tool into the fitting to release the retaining ring. The fuel line can now be pulled off the fuel manifold. Make sure you dispose of the shop towels in an appropriate manner.



27. On the right hand side of the engine, adjacent to the EVAP line you removed earlier is the other end of the fuel line. Place shop towels around the area to catch residual fuel. You can quickly place the line into a strategically placed cup to minimize the leakage.

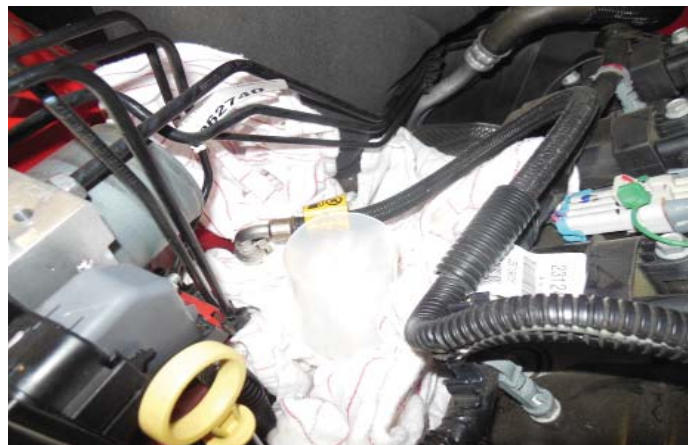



28. Pry out on the safety clip to release the clip from the fuel line/hard line.



29. Once again, press the fitting onto the hard line barb, then press the fuel line removal tool into the connection to release the retaining ring. Now the fuel line can be pulled free of the hard line barb.



30. Place a cap over the fuel line, or improvise one with a section of fuel compatible hose and a plug. Dispose of fuel soaked shop towels in an appropriate manner.



31. Replace the fuel fill cap.



### Section 3: Coil Pack, and Manifold Removal

32. Disconnect the MAP Sensor connection behind the throttle body on the right hand side of the engine.

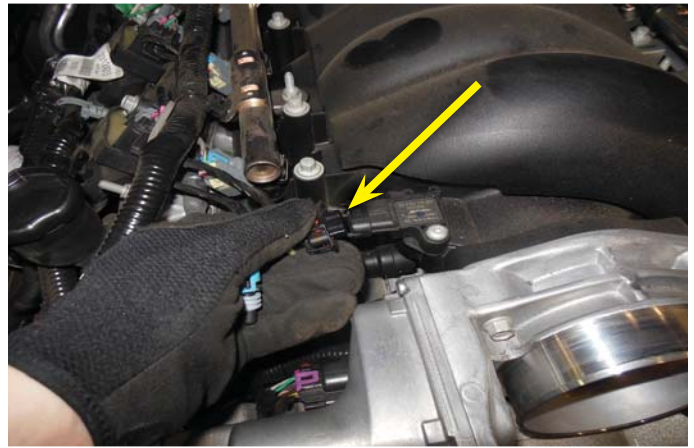

33. Disconnect the throttle body control harness from the throttle body.



34. There is a short PCV tube running from below the intake manifold to a hose barb just below the MAP sensor. Disconnect this fitting.

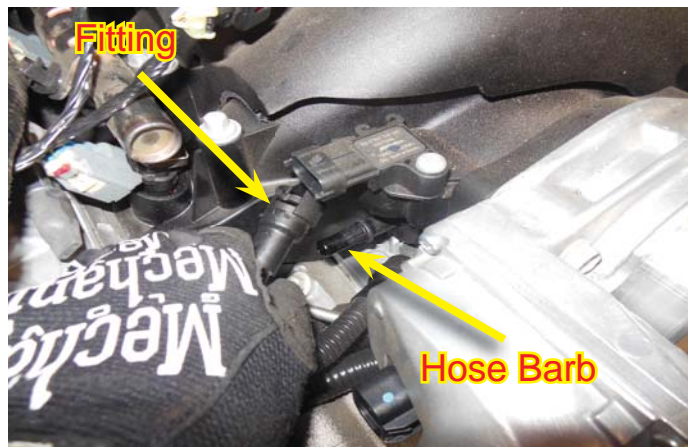

35. Pull the green locking clip from the coil pack main harness connector on each side of the engine.





36. Press the release tab and pull the harness connector from the coil pack mounted connection.

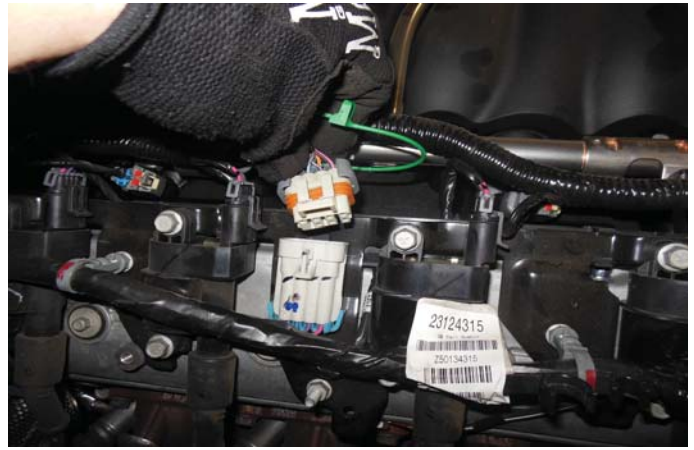

37. Pull the right side harness mounting clips from the coil pack mounting posts on the coil pack bracket.

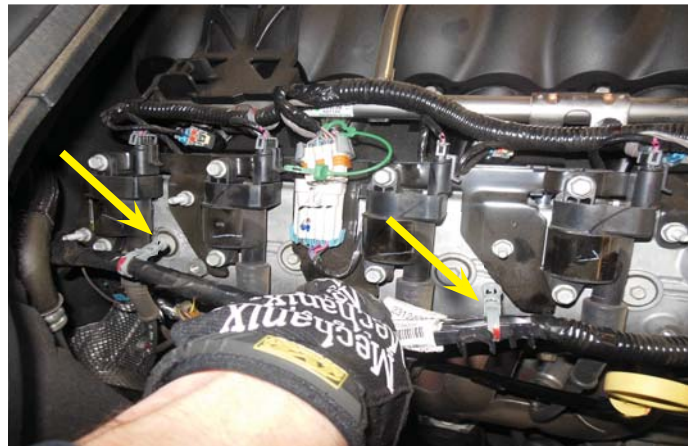

38. Disconnect the plug wires from the coil packs on both sides of the engine.



39. Remove the eight coil pack wires.



40. Use a 10 mm wrench to remove the harness mounting posts/coil pack mounting bracket screws holding the brackets to the valve cover on each side of the engine. There will be five screws per bracket.



41. Remove the coil packs from the engine for modification and later re-installation.



42. Disconnect the injector plugs from the injectors on both sides of the engine.



43. First pull out on the red locking tab then press the sides of the clip to release them from the injectors.

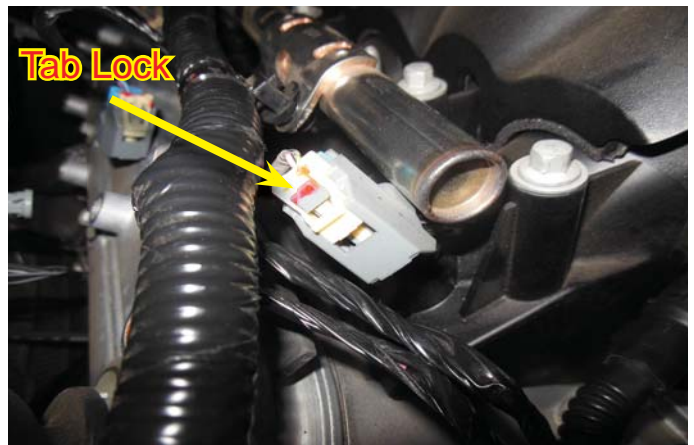



44. Use a pry tool to remove the injector harness mounting “trees” from the holes on the injector manifold mounting tabs.



45. At the back of the engine on the left hand side there may be a Vacuum Actuated Exhaust tube reverses with a 90° fitting just after a 90° bend. Press the green locking tabs to release the tube from that connection if equipped.

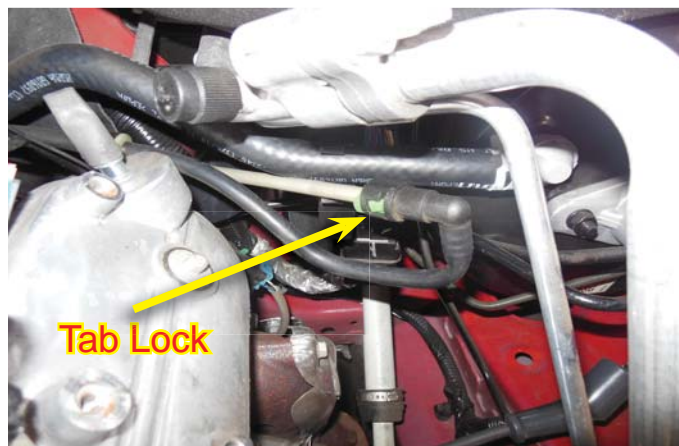

46. Pull the brake booster connection from the brake booster grommet at the back of the engine compartment on the left hand side.



47. Use a 10 mm wrench to remove the bolts holding the bracket over the intake manifold at the back of the engine.



48. Remove the bracket from the engine.



49. Use a 10 mm socket to remove the ten bolts holding the intake manifold to the heads.

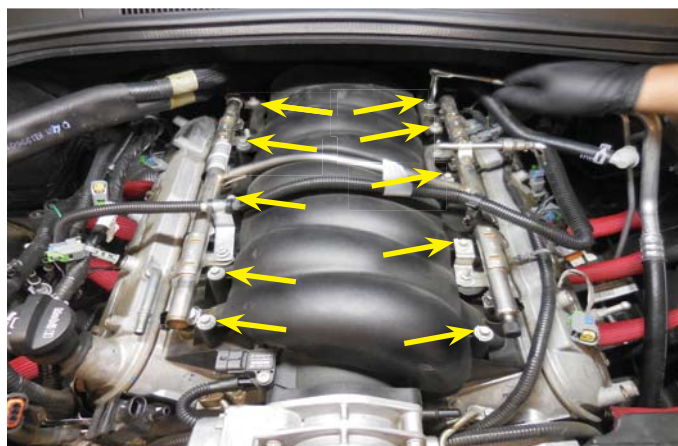

50. Have an assistant help you to carefully lift the OEM intake manifold from the engine. Set aside for parts removal to incorporate with your new supercharger installation.



51. First use a shop vacuum to remove any loose contaminants from around your heads and valley cover area.





52. Now use a shop towel with denatured alcohol, or some other non-petroleum based solvent to clean around all the intake openings.



53. Use tape or shop towels to cover the intake ports.

**It's VERY important to not contaminate your work environment or allow any debris to fall into the exposed ports, engine damage CAN occur.**



#### **Section 4: Coolant Line and Air Box Removal**

54. Earlier you removed one end of a short looping tube from the intake manifold on the right hand side of the engine. The other end of this tube is now exposed. Release the locking tab and pull this tube off the valley cover hose barb. Retain tube for re-installation later.



55. Place a rag down as shown to catch any coolant. Disconnect the hose from the coolant vent pipe on the left hand side, front of the engine. Disconnect the other end of the coolant vent pipe hose from the barb on the left hand side of the radiator fill cap.

**Note: Avoid spilling any coolant on the belts and pulleys. The smallest amount of coolant can cause the new belt to be noisy.**



56. Pull up on the harness mounting rings that hold the harness to the water pump hose on the left hand side of the engine.



57. Disconnect the MAF sensor harness connection from the MAF Sensor on the OEM air box.



58. Release the locking clips on the air box cover and remove the air box lid from the OEM air box.



59. To minimize fluid mess, place shop towels below the water pump hose barb, remove the mounting clamp and pull the upper radiator hose from the water pump hose barb.

**It's VERY IMPORTANT to not get coolant on your engine pulleys. The smallest amount can cause "Belt squeaking".**





60. Also place towels below the radiator end of the upper radiator hose, remove the clamp and pull the radiator hose off the left hand side, upper radiator hose barb.



61. Disconnect the radiator fan control plug from the receptacle on the right hand side of the radiator.



62. Use a 10 mm wrench to remove the radiator fan mounting screws from the radiator mounting tabs.



63. At the center of the radiator on the engine side there may be a pinch clip holding the fan shroud to the radiator. Pinch this together to release the upper mounting tab if equipped. Unclip overflow hose.



64. The radiator fan shroud should now be able to move somewhat freely.

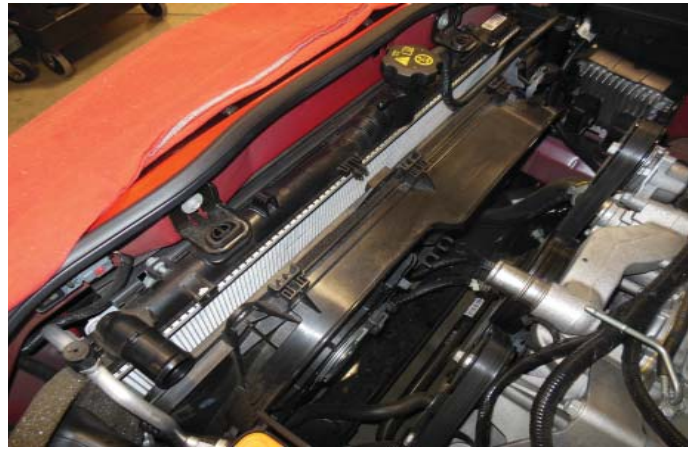

65. Remove the radiator fan shroud from the vehicle for later re-installation. You should be able to lift upwards on the shroud to remove from the engine bay.



## Section 5: Crank Pulley Pinning

66. Use a 24 mm socket and impact wrench to remove the main crank pulley mounting bolt. You may need to apply some heat to the bolt to aid in removal.



67. This is the pin drill guide and provided mounting bolt. The stepped side faces towards the crank to center with the pulley.





68. Replace the removed crank pulley mounting bolt with the provided drill guide and mounting bolt. It's easier if you have the holes of the drill guide oriented horizontally for visibility purposes. Torque this down to at least 24 ft-lbs.



69. Place a strip of visible tape around the top of the last step of the provided step-drill for visibility purposes. Use a drill motor to drill out the crank and pulley completely to the second step of the provided step drill. You can easily see when you have gone far enough when the visible tape touches the face of the key way guide.



70. Use compressed air to evacuate the particles from the new holes.



71. Vacuum out area to clear metal chips.



72. Install the reamer bit in your drill motor and ream out your holes. Once again use compressed air to remove debris from the two holes. Now remove the drill key way guide and mounting bolt using a 22mm socket.

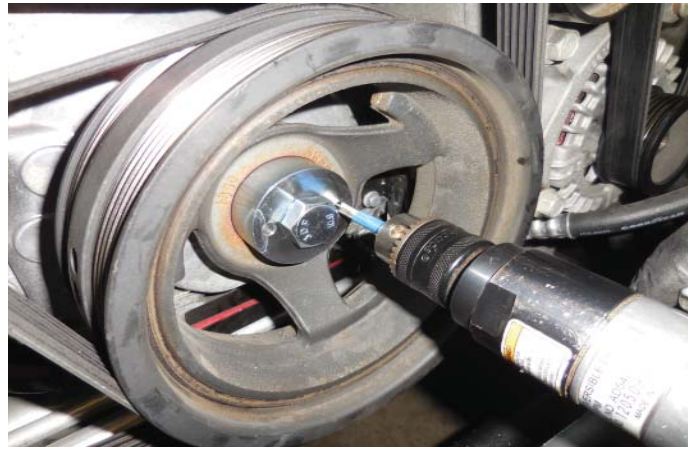

73. Place two provided pins into the holes. Use a drift pin, or nail set to ensure that the two pins get completely into the holes.



74. This picture shows that the pins are behind the surface where the pulley bolt will touch.

**Make sure the pins are below the contact surface for the harmonic balancer bolt.**



75. Install the new provided factory GM harmonic balancer bolt. Using a 24 mm socket, tighten the new harmonic balancer bolt according to the GM specifications.

- Tighten to 50 N-m (37 ft-lbs) using a torque wrench. Verify your torque wrench settings
- Tighten an additional 140° using a torque angle meter.





## Section 6: Idler Pulley Replacement

76. Use a 15 mm socket to spring the tensioner to allow the outer accessory drive belt to be removed.



77. Use a 15 mm socket to remove the two tensioner mounting bolts.



78. Remove the OEM tensioner assembly from the vehicle and set aside along with the fasteners from the previous step. The tensioner, and bolts will be reused.



79. Below and between the tensioner mounting bosses use a 10 mm socket to remove the indicated bolt. This will not be reused.



80. We will be using this vacated hole to mount the new tensioner assembly.

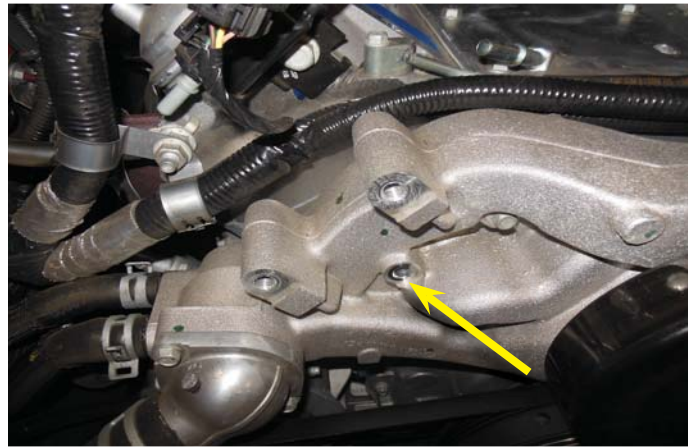

81. Use a 15mm wrench to mount the new tensioner/idler pulley mounting bracket in the holes vacated using the OEM bolts removed earlier. Use a 12 mm socket to secure the provided bolt below and between the removed tensioner mounting bolts.



82. Torque the two 15 mm hex mounting bolts to 30 ft-lbs, and the 12 mm hex mounting bolt to 18 ft-lbs.



83. Re-mount the OEM tensioner to the new tensioner mounting bracket torquing the two provided bolts to 30 ft-lbs with a 15 mm socket.





84. Mount the provided Idler pulley with the side showing in the photo facing out using the provided bolt to the boss between the crank pulley and the tensioner pulley.

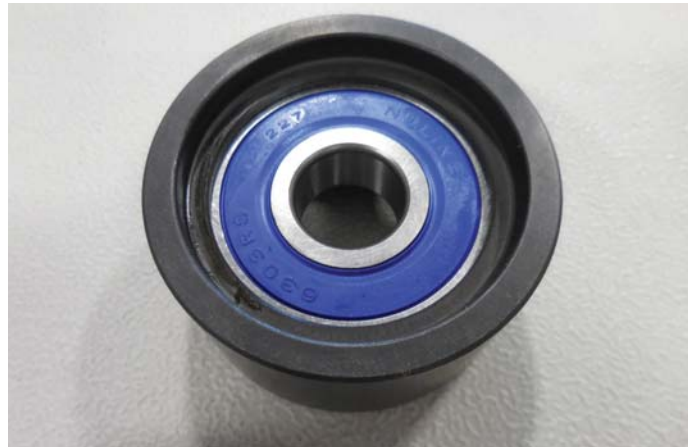

85. This photo shows the location for the provided idler pulley shown in the last step. Torque the mounting bolt for the provided idler pulley to 30 ft-lbs.

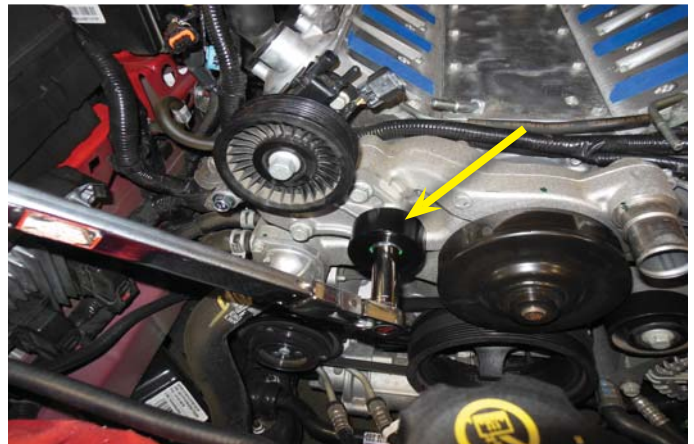

## Section 7: Steam Pipe, and Coil Pack Replacement

86. Use a 10 mm socket to remove the two bolts holding the OEM steam pipe to the heads.



87. Remove the OEM steam pipe, this will not be reused. Remove the old O-rings from the cylinder heads if they did not come off with the steam pipe. Retain a 1" section of the protective slit hose for a later step.



**NOTE: Make sure there is a new O-ring installed on the bottom side of each block of the provided steam pipe before installing!**

88. Mount the provided steam pipe to the vacated bosses on each head, secure in position with the OEM mounting bolts and torque to 108 in-lbs. Verify your torque wrench settings.

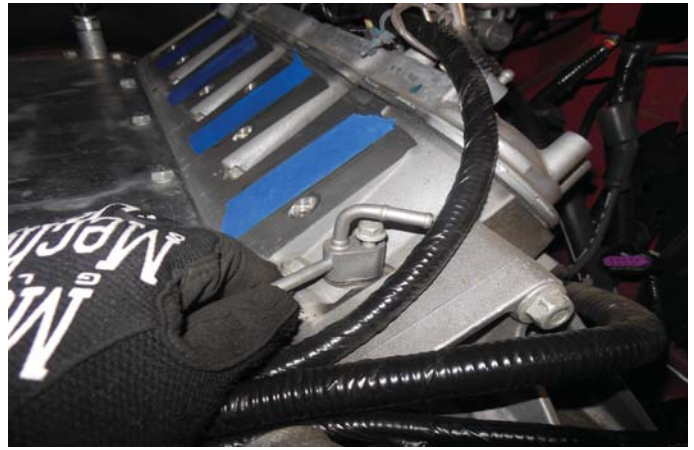

89. This image shows the OEM coil pack and the new provided coil pack mounting bracket with nuts and spacers.



90. Start by disconnecting each harness wire from the coils on both OEM coil pack set assemblies.



91. Use a 10mm socket to remove the mounting bolts holding the coils to the OEM mounting brackets.





92. This is a separated coil pack set, mounting bolts, and remaining bracket.



93. Use a flathead screwdriver to release the tab holding the harness female plug terminal to the mounting brackets.



94. Pull the plug terminals away from the brackets.



95. This shows the plastic cover over the wiring harness attached to the coil pack mounting brackets.



96. Use a small flathead screwdriver to release the tabs locking these covers over the harnesses on the mounting brackets.



97. Remove the covers completely from the wiring harnesses, and separate harnesses from the mounting brackets.



98. Orient the OEM wiring harnesses with the plugs at the top, lay the bracket down over the wiring harness tongue that goes to the main female plug. The studs should be pointing up as shown in this picture.



99. Slide the metal mounting tab on the back of the plug into the slot on the new coil pack mounting brackets completely as shown. The "Teeth" of the metal tab will lock the plug in position. You can place a block under the plug face and press the brackets down onto the plug as shown in this picture.

**Make sure the "teeth" of the metal mounting tab bite into the bracket, locking it in place.**

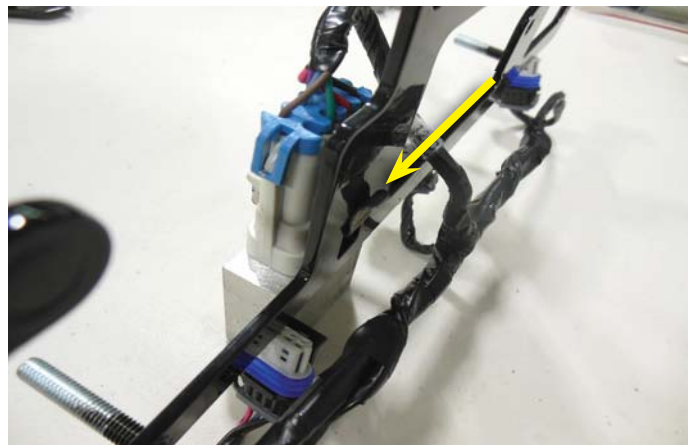



100. Place a provided spacer on each of the studs on the new coil pack mounting brackets.

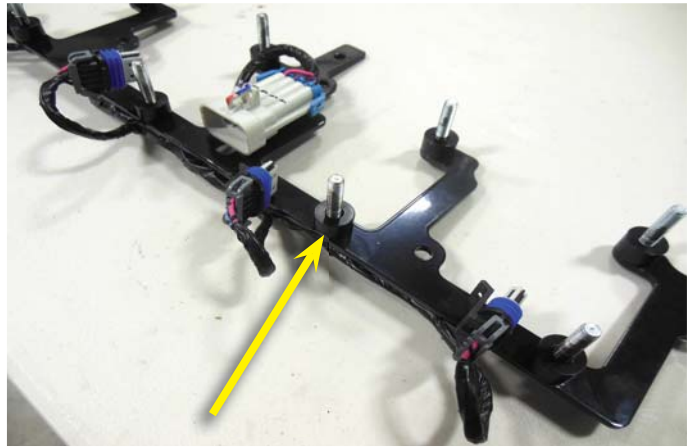

101. Use a 10 mm nut driver or wrench to secure the OEM coils to the new coil pack mounting brackets with nuts. The harness female plug should be oriented to the flat "top" of the mounting brackets, the receptacle for the plug wires will be pointed in the "down" direction, same as the "tongues" of the new mounting brackets. Torque the nuts to 108 in-lbs. Verify your torque wrench settings.

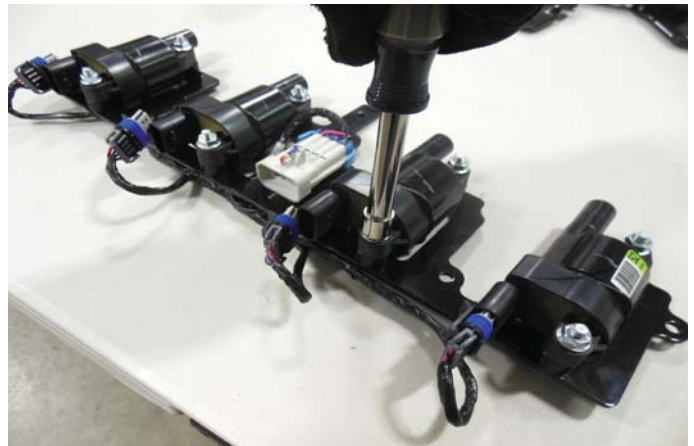

102. Connect the plugs to each of the coils on the mounting brackets.



103. This shows the completed assembly with the OEM parts that will not be reused above. We suggest that you keep your OEM parts separate in case you want to return your vehicle to "stock" and mount the supercharger system on your next Camaro.



## Section 8: EVAP Solenoid, and Manifold Parts Removal

104. Use a small screwdriver to spring the release tab on the EVAP Solenoid mounting bracket. Remove the EVAP Solenoid from the vehicle and put aside for reinstallation later.



105. Use a 15 mm wrench to remove the EVAP Solenoid mounting bracket from the right hand side, front of the head. The bracket and fastener will not be reused.



106. Connect the provided throttle position control extension harness to the OEM throttle control put on the right hand side of the engine just behind the tensioner pulley.



107. Route the harness behind the water pump, under the steam vent pipe and over to the left hand side of the engine. Secure to the existing harnesses using the provided zip ties.





108. Use a pry tool hook to remove the injector harness mounting tie “trees”. These will not be reused. You can also cut them off, just be careful to not damage the harness.

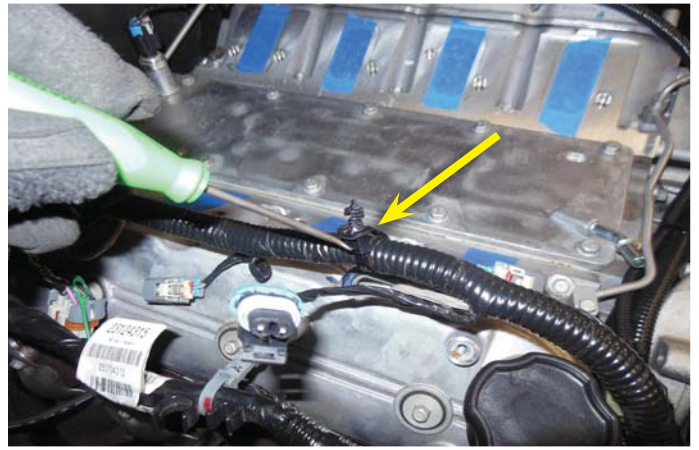

109. Use a pair of diagonal pliers to cut the existing stand-off mounting tabs from the coil pack harness as shown.

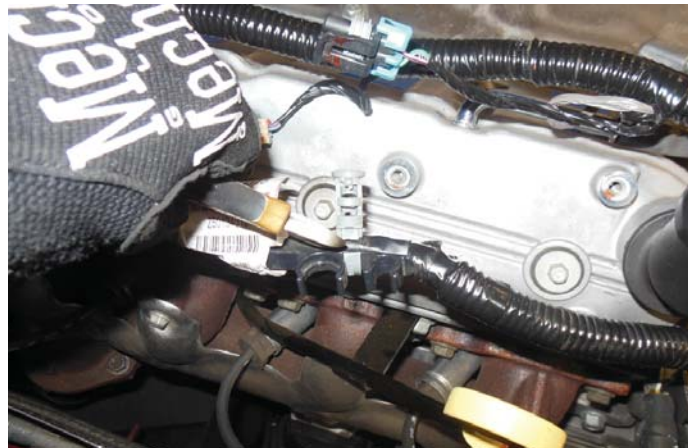

110. Use a 10 mm socket or nut driver to remove the four throttle body mounting bolts from the OEM intake manifold. Remove the throttle body, and bolts and set aside for later install.



111. Remove the Schrader valve cap from the OEM fuel rail.



112. Use a small flathead screwdriver to release the injector locking clips from the injectors on the OEM fuel rail.

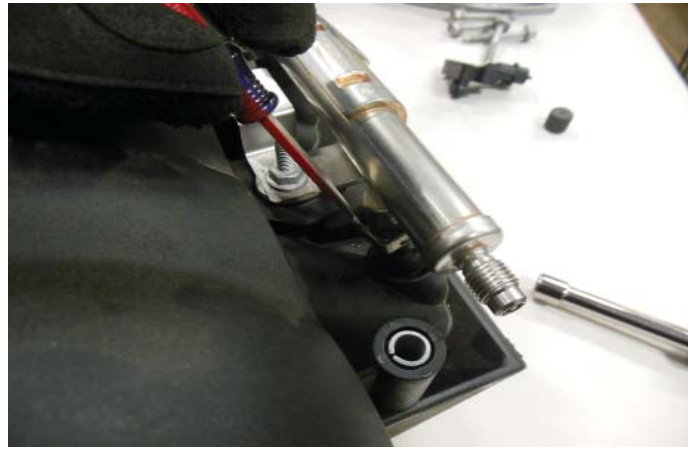

113. Remove the clamp securing the brake booster. Remove the fitting and the hose clamp and set aside for later use.



114. Connect the OEM brake booster valve to the end of the supplied hose that is closest to the mesh sleeve, securing in place with the OEM spring clamp.



115. If equipped, pull the vacuum hose from the back of the OEM intake manifold next to the vacuum hose that went to the brake booster.





116. This is the line removed from the OEM intake manifold. Save it for later use.



## Section 9: Fuel Rail Preparation, and Supercharger Install

117. Place a small bead of Lubriplate lubricant on the injector port openings of the supercharger system.



118. This shows the provided fuel rail and new injectors with the OEM injector mounting clips and Schrader valve cap.



119. Place the OEM Schrader valve cap on the pressure release valve on the new fuel rail.



120. Place a small bead of Lubriplate lubricant in the cups of the fuel rail.



121. Install the new high flow injectors in the cups of the fuel rail, and orient the injectors with the plug receptacles pointing out.

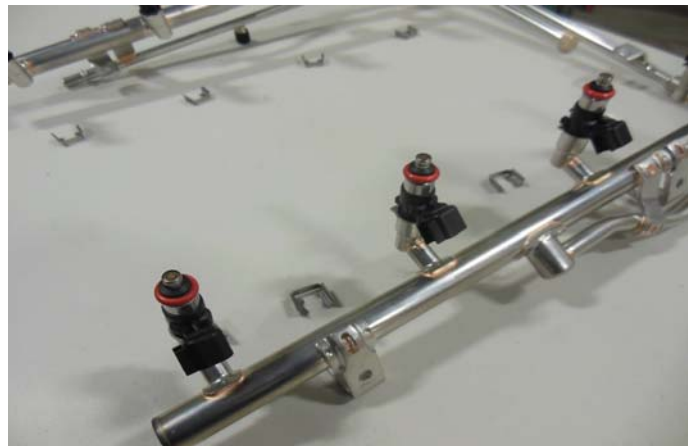

122. Press the injector mounting clips onto the injectors securing them to the provided fuel rail.



123. This picture shows the provided EVAP extension harness and new EVAP hose extension.

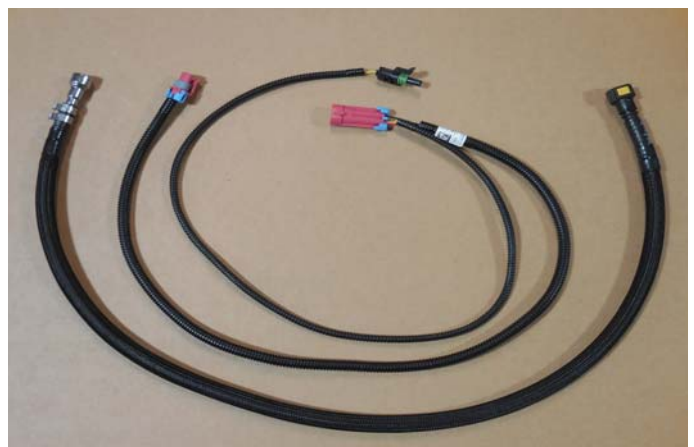



124. Press the EVAP hose extension onto the EVAP hard line on the right hand side of the engine, behind the heat shield adjacent to the capped fuel line.

**You should feel/hear the locking ring engage, this should not be able to be removed without using the fuel line removal tool. Check your connection.**

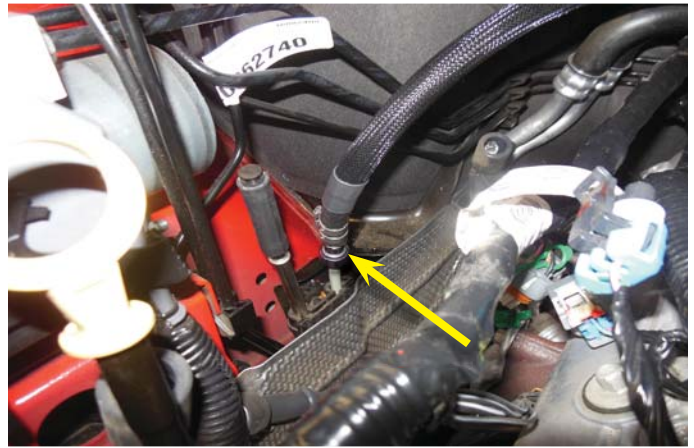

125. Connect the EVAP breakout harness wire onto the plug on the injector harness on the right hand side of the engine adjacent to the oil fill spout. Route the single yellow wire connection off toward the right fender. It will be secured in a later step.



126. Route this EVAP breakout harness wire back to the fire wall, over to the left hand side of the engine. Secure to the existing harness using the provided cable ties. Secure hose/harness to a heater hose at one point to prevent the hose from sagging.

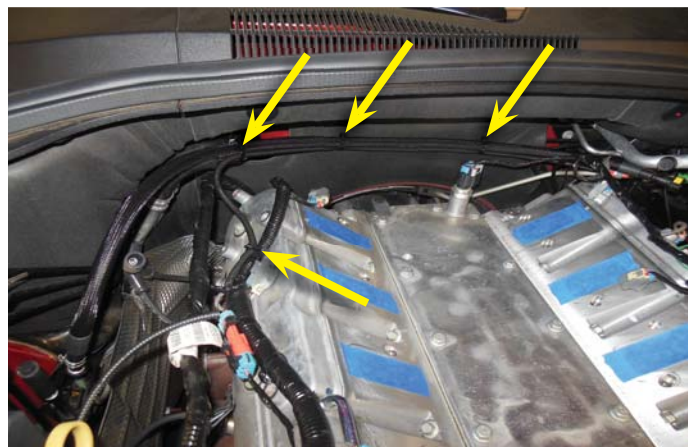

127. Temporarily place a small section of your old split hose over the cross-over steam pipe just below the PCV hose barb coming out of the valley cover at the front right hand side of the engine.



128. Use a drift pin, or medium Phillips head screwdriver as a lever. Push the end into the PCV hose barb, and carefully lever the barb down until your “tool” just touches the split hose protecting your steam pipe. This should give you a bit more than ¼” clearance were the tube to actually extend beyond the steam pipe.



129. Remove the section of split hose from the steam pipe. Ensure that the OEM fitting will still go on the “adjusted” barb. The OEM fitting should just barely clear the cross-over. The “U” shaped short tube connection removed earlier is going to be reused here. If it doesn’t clear the cross-over pipe, adjust as necessary.



130. This is your supercharger assembly. It’s a good idea to place a cap or tape over the supercharger inlet to protect from debris. Remove the bolts holding the supercharger lid (cover) to the housing and pull the lid (holding the intercooler assembly) off the housing. Place the lid aside for re-install shortly. Ensure that the lid is in a clean location and preferably covered to prevent any contamination by debris.



**NOTE: Take note of what length fastener is used in each location.**

131. Flip the supercharger housing upside down on a clean surface. It’s a good idea to protect the surface from scratching or dings, we suggest using clean shop towels or cardboard as a buffer. Install the provided gasket plates over the supercharger intake manifold ports. They should snap into position and stay without falling out.





132. Remove the tape or shop towels covering the intake ports on your heads, and clean using alcohol or some other non-petroleum based solvent using a clean shop towel.



133. It's helpful to spray the heads, or gaskets, with a mist of silicone spray, or mild soapy water to aid in this step. With the help of an assistant, carefully guide the supercharger housing assembly onto the heads, aligning the ports and mounting bolt holes.



134. Carefully slide the assembly around to achieve alignment. There should not be any "rocking" or "tipping" when the supercharger is completely contacting both heads evenly. Connect the short "U" tube PCV hose to the modified barb on the valley cover, and the adjacent hose barb on the supercharger assembly. Make sure the PCV tube does not interfere with the supercharger assembly.



135. Place a small bead of supplied blue Loctite 242 on the ten supplied M6 x 40mm supercharger mounting bolts.



136. Very carefully insert the provided M6 x 40mm supercharger mounting bolts through the holes in the outer ring of the supercharger. It's a good idea to use a magnet tool to avoid the bolts dropping into the exposed ports.



**NOTE: Make sure your tape has been removed from the intake ports.**

137. Before torquing, first snug (hand tighten) all fasteners using the tightening pattern shown in the next step. Torque the mounting bolts down following the pattern shown in the next step to 108 in-lbs.



**NOTE: Do not immediately torque each bolt to full specs, do this in steps!**

138. This picture shows you the torque sequence.

**There is a larger version of this diagram at the back of this installation manual.**

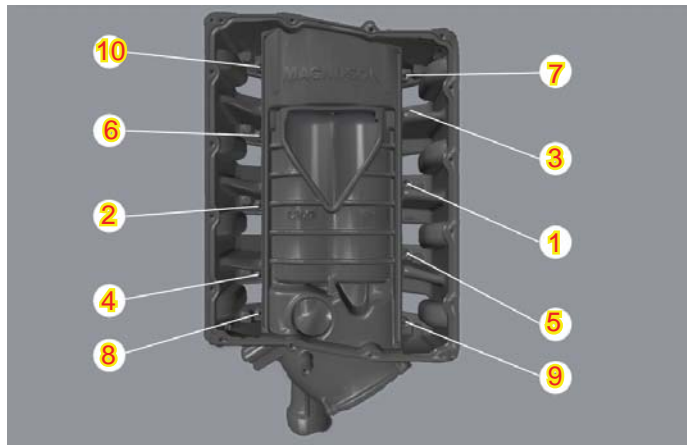

**NOTE: If your vehicle is equipped with an oil separator, skip the next two steps.**

139. Connect the provided PCV hose to the hose barb on the right hand side, front of the valve cover. Secure in position with one of the provided dark-gray spring clamps in the area shown with a yellow arrow. Place a swivel clamp to connect the hose to the harness shown with a blue arrow.





140. The hose from the last step will be routed to the right for now. The opposite end will be attached to the air inlet later in the installation.



141. Connect the MAP sensor connector to the MAP sensor on the right hand side of the supercharger assembly just behind the bypass valve.



142. Ensure that the gasket on top of the supercharger assembly is properly seated, place a small film of Lubriplate lubricant on the gasket and while you're doing this, feel for inconsistencies! Your fingers are more sensitive than your eyes.



143. Verify that your supercharger lid is clean and relocate the lid on top of the supercharger assembly.

**NOTE: There are alignment pins in the front left hand corner, and rear right hand corner.**



144. These are the supercharger lid mounting bolts, note the four sizes and locate appropriately. Place a small bead of blue Loctite 242 on each of the mounting fasteners. Some of the fasteners will be located in a separate bag with the other sub-assemblies.



145. Start each of the fasteners by hand and finger tighten in a criss-cross, center-out pattern. Use the tightening sequence shown two steps later.



146. Torque the fasteners down to 108 in-lbs in steps using the sequence shown in the next step.

**NOTE: DO NOT immediately torque each bolt to full specs, do the torquing in steps!**



147. This image shows the torquing sequence.

Fastener Length

20 mm: 9, 10, 11, 12, 13, 14 (9-14)

25 mm: 15, 16

50 mm: 1, 2, 3, 4, 5, 6, 7 (1-7)

60 mm: 8

**There is a larger version of this diagram at the back of this book.**

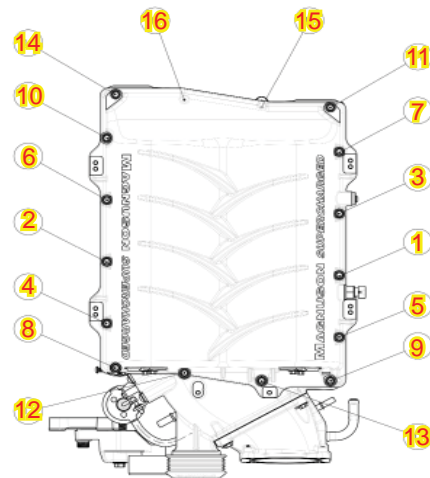



148. Install the fuel rail starting with getting the right hand side in position then rotating the left hand side down over the supercharger inlet.



149. Align the left hand side injectors with the mounting ports and press the injectors carefully into each port.



150. The fuel rail manifold mounting bracket holes should align with the mounting holes in the supercharger lid as shown.



151. When both sides of the injectors are in place, start installing the mounting bolts. Finger tighten all mounting bolts, including the one on the crossover pipe above the supercharger inlet.

**NOTE: The back, left hand side mount will incorporate the provided EVAP Solenoid mounting bracket above the fuel rail mounting flange.**



152. Torque the mounting bolts down to 108 in-lbs using a 10mm socket.



153. Connect the injector plugs to the adjacent injectors ensuring that they snap into place. Engage the locking clips.



154. On the right hand side of the engine, tuck the wiring harness below the mounted fuel rail.



155. Place a bead of Blue Loctite 242 on the new coil pack mounting bolts shown here.





156. Install the new coil pack mounting bracket assemblies on the valve covers and torque the mounting fasteners down to 108 in-lbs with a 10 mm socket.



157. Connect the harness coil pack plug to the coil pack bracket connectors on both sides of the engine.



158. Engage the locking clips securing the coil pack connectors in position.



159. Reconnect the plugs to the coils on both sides of the engine. Ensure you get the wires and jackets completely in position.



160. Connect the EVAP tube you routed behind the engine earlier to the OEM EVAP solenoid rear barb. Connect the EVAP breakout harness wire electrical connection you also routed behind the supercharger to the EVAP solenoid.

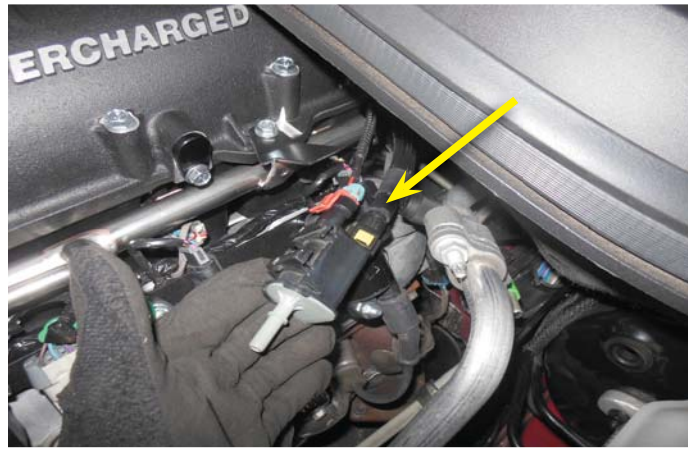

161. Mount the EVAP solenoid to the clip on the back left hand side of the fuel rail bracket installed earlier when the fuel rail was mounted to the supercharger assembly. The EVAP solenoid should clip into place just like the OEM bracket.



162. This stud on the coil pack mounting bracket is being used to anchor the wire harness shown in the next step. We will re-use the OEM fastener in this location on the right side of the engine.



163. This is the stud mounting clip with the OEM tie removed.





164. Slide a provided cable tie through the top hole of the stud mounting clip as shown.



165. Align the assembled mounting clip/cable tie on the wire harness, with the mounting stud and pull the cable tie tight anchoring it to the wire harness.



166. Press the mounting clip onto the stud securing the harness in position.



## Section 10: Belt, Radiator, and Throttle Body Installation

167. Use a 15 mm wrench to rotate the tensioner and install the accessory drive belt as shown.

**Use the belt diagram given at the back of this installation manual.**



168. Verify that the radiator drain petcock on the left hand side, bottom of the radiator is closed and everything is clear behind the radiator.



169. Slide the fan shroud back down behind the radiator carefully, ensure that the clips at the bottom of the shroud have engaged with the mount locations on the radiator, and engage the center mounting tabs with the shroud to hold it in position.



170. Secure the fan shroud to the radiator mount using the OEM mounting hardware.



171. Re-connect the wiring harness to the radiator shroud mounted connector.

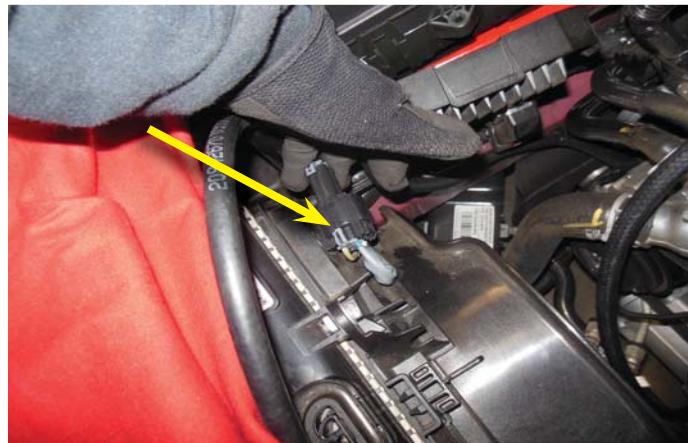



172. Re-connect the OEM radiator hose to the water pump hose barb using the OEM spring clamp. Reconnect the free end of the hose back to the upper radiator hose barb on the left hand side of the radiator using the OEM spring clamp.



173. Re-connect the wiring harness mounting clips to the just re-connected radiator hose.



174. Connect the provided steam vent hose to the cross-over steam vent connector on the left hand side of the heads, below the super-charger housing inlet. Secure in place with one of the provided black spring clamps.



175. Route the hose over to the water pump hose connection and secure to the hose using a provided cable tie connector.

**DO NOT over tighten the cable tie, it's there to guide the hose not collapse it.**



176. Connect the free end of the hose to the hose barb on the left hand side of the radiator fill cap. Secure in place with the remaining black spring clamp provided.

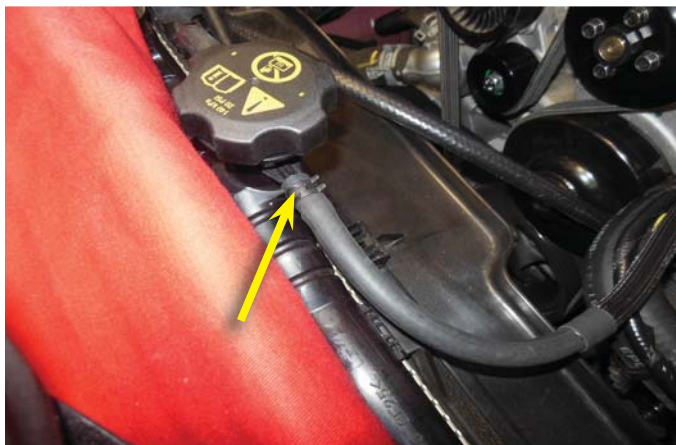

177. Make sure the throttle body O-ring is installed and fully seated. If you installed a cap or tape on the inlet throat, remove the cap from the supercharger inlet.



## Section 11: Hose Line and Electrical Connections

178. If equipped with an exhaust actuator you will have the OEM hose shown here that you removed in Section 8. Remove and discard the section to the right of the connector shown with the arrow. It will be replaced with the provided 1/4" diameter 21" length hose. If your vehicle does not have this feature you can skip ahead to step #184.



179. Route the provided 1/4" diameter 21" length hose back below the injector connectors on the left hand side of the engine, between the valve cover and supercharger housing casting.





180. Pull the 1/4" diameter 21" length hose out behind the EVAP solenoid and out toward the left hand side fender to gain access as shown.

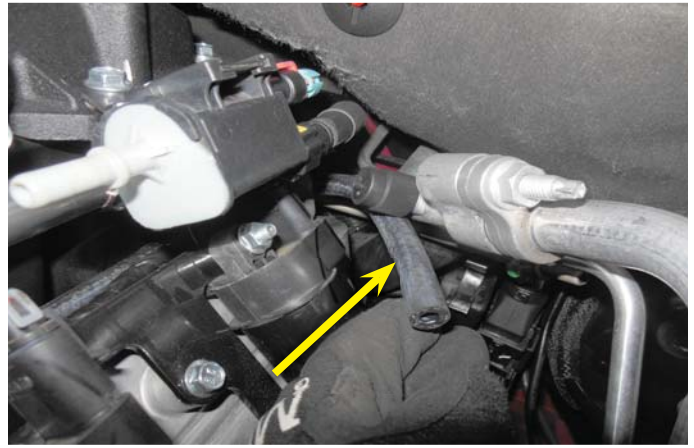

181. Connect the OEM hose shown at the beginning of this section to the hose installed in the last step.



182. Connect this connector to the hard line with the green locking tab by the firewall adjacent to the brake booster on the left hand side of the engine.



183. Pull the 1/4" diameter 21" length hose toward the front of the supercharger taking up the slack, and connect the free end to the vacuum hose barb at the center of the supercharger inlet where shown with the arrow.

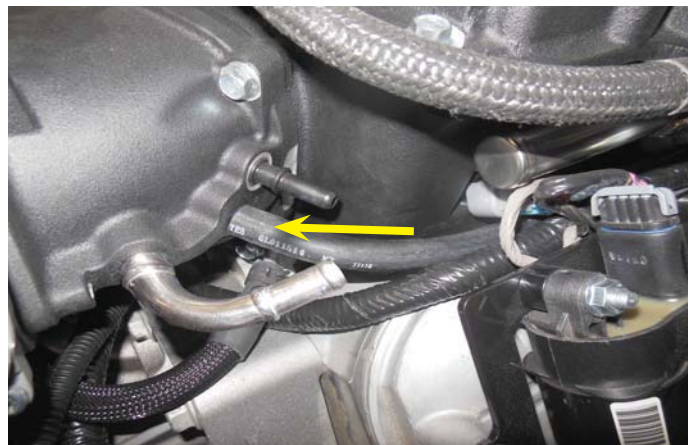

184. Connect the provided vacuum hose between the EVAP solenoid and the hose barb at the top of the supercharger inlet on the left hand side of the engine. Make sure the connections have “clicked” and are locked in place.

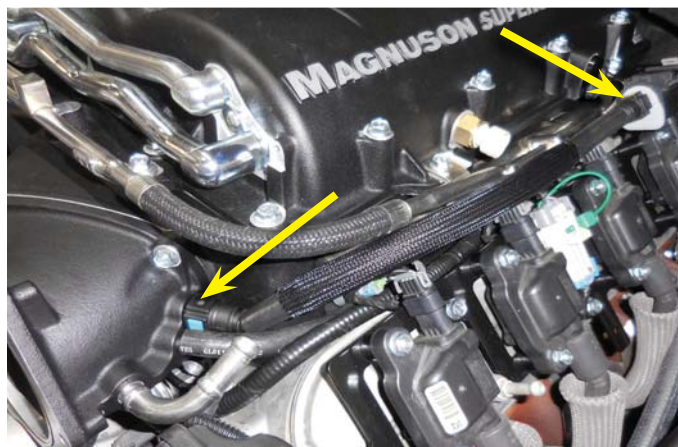

185. Gather the brake booster hose that was built in an earlier step for reinstallation.



186. Plug the brake booster valve back into the brake booster grommet. Route the free end of the hose under the AC hard lines, above the coil packs and forward on the left hand side of the engine.



187. Connect the free end of the brake booster hose to the remaining hose barb on the left hand side of the supercharger inlet.





188. Use the provided hose clip to anchor the EVAP solenoid hose to the brake booster hose.



189. Connect the right angle connector of the provided fuel line to the back of the right hand side fuel rail connector. Pull on this connection, you should NOT be able to disconnect this hose without using a fuel line removal tool. Re-install the OEM fuel line locking clip.



190. Connect the remaining end of the provided fuel line connector to the fuel line connection behind the heat shield on the right hand side of the engine compartment, just forward of the EVAP hose connected earlier. Again, pull on the connection, it should not be able to be removed without a fuel line removal tool. When verified, reinstall the fuel line locking clip. Use the provided cable ties to tie the fuel line and the EVAP line together making sure they are only holding the lines together, not compressing.

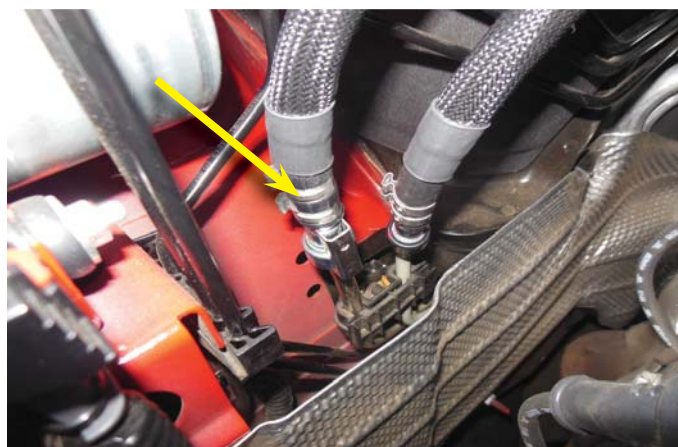

191. Use the provided cable ties or a hose connecting clip (shown here) to tie the fuel line and the EVAP line together near the firewall at the back of the right hand side of the engine compartment. If you use cable ties be sure they are only holding the lines together, not compressing.



192. Route the provided IAT sensor connector/harness below the inlet.

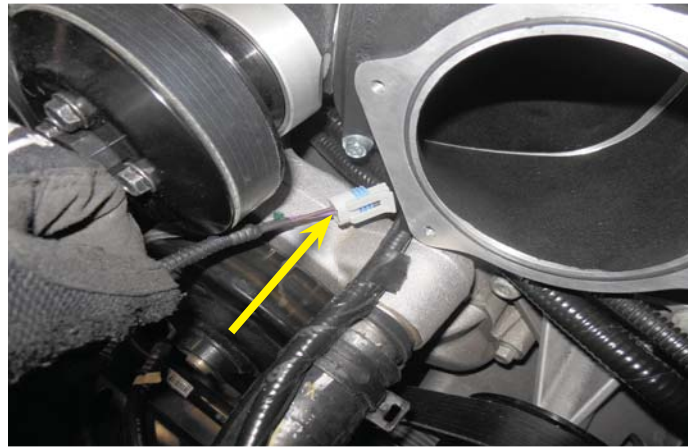

193. Route the harness below the vent pipe hose and toward the IAT sensor.

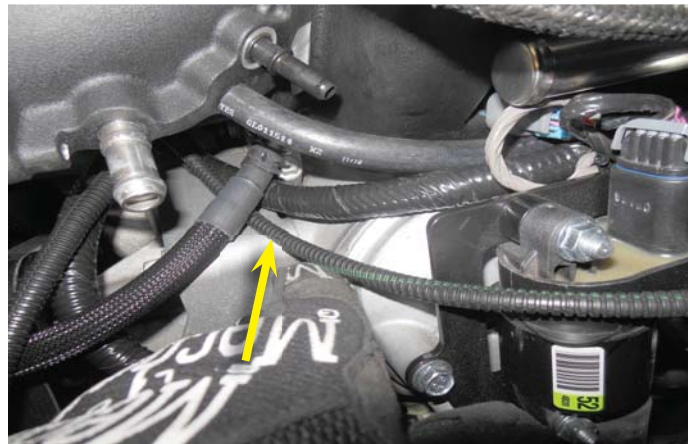

194. Attach the connector to the IAT sensor. Tuck the harness back behind the coil pack bracket and anchor to existing harness using provided cable ties.

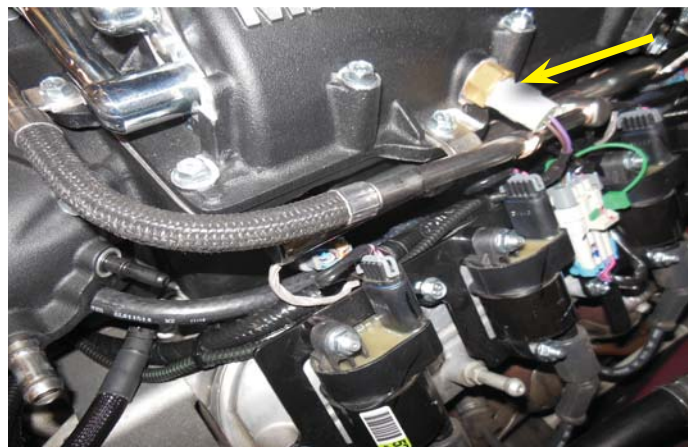

195. Anchor the harness to the existing hoses/harness at the water pump inlet hose barb.

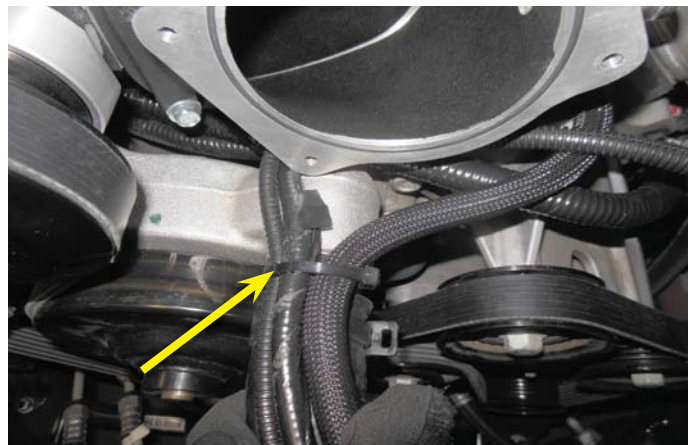



196. Continue to anchor to the harness along the radiator hose until you reach the air box.

**DO NOT over tighten the cable ties.**



197. Re-snap the air box lid in position on the air box, and connect the MAF plug from the IAT breakout harness that you anchored to the radiator hose to the sensor on the air box throat. Connect the breakout harness plug to the OEM harness MAF plug connector.



198. Install the OEM throttle body to the supercharger inlet using the OEM fasteners, and torque these bolts to 108 in-lbs.



199. Attach the throttle extension harness plug to the throttle connector.



200. Connect the provided inlet air tube. Secure in place with the provided worm gear hose clamps using an 8mm nut driver or flat head screwdriver.



201. If your vehicle is equipped with an oil separator, install the provided connector in the end of the hose closest to the fiber wrap as shown. If your vehicle is not equipped with an oil separator you already installed this hose in an earlier step to the PCV hose barb near the front of the right hand side valve cover, between the valve cover and supercharger intake manifold. In both cases, on the opposite end, install the 90° hose mender provided.

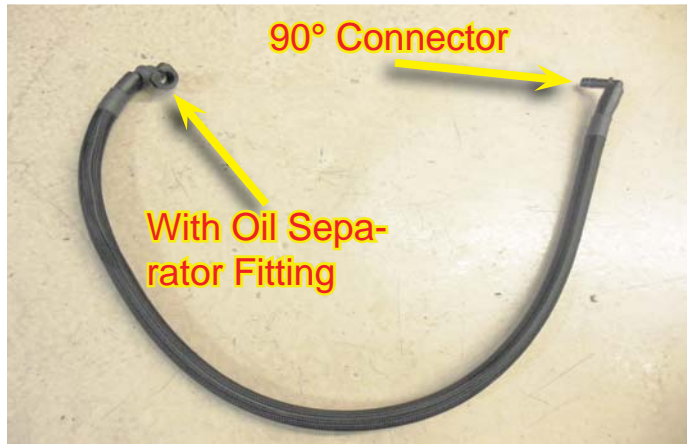

202. If your vehicle is equipped with the oil separator, connect the just installed connector to the barb on the oil separator neck.



203. Anchor the hose from the last step to the existing harness near the fuse center using the provided tube mounting clamp or cable ties. Do NOT over tighten cable ties, they are to restrict movement, not compress tubes.





204. If your vehicle does not have an oil separator, you already connected to the existing PCV hose barb near the front of the right hand side valve cover, between the valve cover and supercharger intake manifold (shown with the arrow). This barb is capped on an Oil Separator provided installation.



205. Route the other end of this hose outside the oil separator/oil fill spout, or PCV, over to the intake air tube and press the 90° fitting into the hole on the intake air tube.



## Section 12: Front Fascia Removal

206. Pry up on the locking tab of the six push pin rivets on the top of the fascia grill using a flat head screwdriver or pry tool.



207. When the locking tab of the push pin rivet is up, the bottom spreader can be pried up using again, a flat blade screwdriver or pry tool.



208. This shows the six upper push pin rivet locations. There may be shims installed between the bumper fascia and frame under these six points. Be careful later when removing bumper.

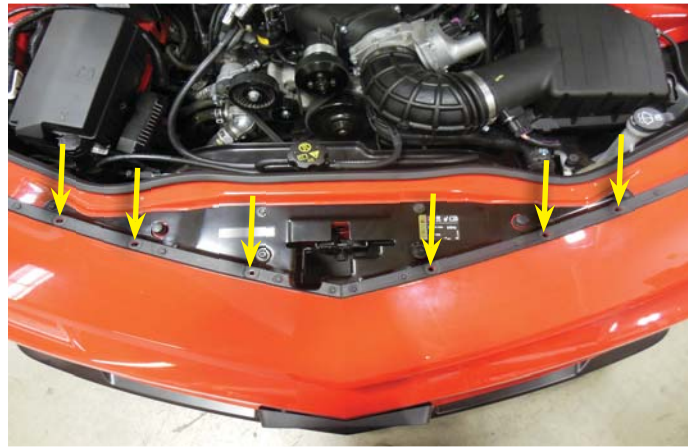

209. Use a 10mm wrench to remove the two bolts connecting the fascia/grille to the sub frame at the bottom of the vehicle.



210. Disconnect the three 7mm bolts holding the plastic wheel well to the underside of the fascia.

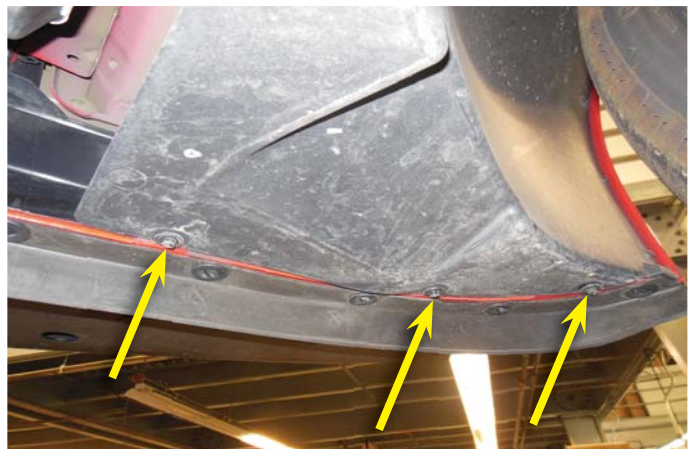

211. Several steps will be more accessible with the front wheels removed. Follow the instructions in your owner's manual for vehicle lifting, and wheel removal.





212. Use a T20 Torx screwdriver to remove the fasteners holding the wheel well to the perimeter of the fascia/grille, and fender.

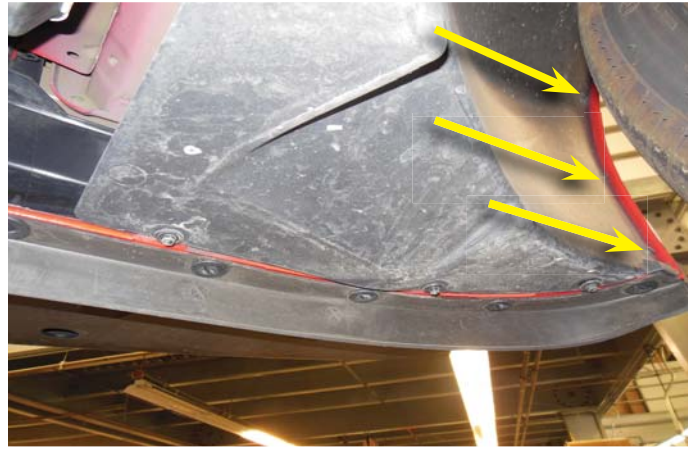

213. The plastic wheel wells need to be removed completely to facilitate fascia/grill removal. Pry out the push pin rivets that secure the wheel wells to the sub-frame. Remove the T20 Torx fasteners at the perimeter and remove the plastic wheel wells from the vehicle, set aside for later re-install.



214. Remove the now exposed fascia/grille mounting bolts holding the assembly to the vehicle. There are three that need to be removed with a 10mm socket and one with a 7mm socket.

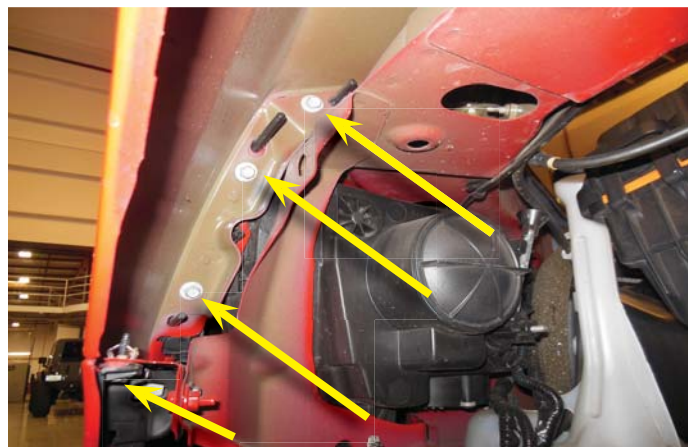

215. Disconnect the harness connection for the lights at the right hand side forward at the grille.



216. Remove the two (one each side) remaining bolts holding the fascia/grille to the vehicle at the top corners, verify everything is disconnected and carefully remove the fascia/grille from the vehicle. The fascia/grille should simply pull away.



### Section 13: Low Temperature Radiator (LTR) Installation

217. The three plastic air deflectors (one on each side of the radiator, and one splash shield below) that need to be removed temporarily. These are held in place with push pin mounting fasteners. Carefully pry these fasteners out to remove the deflectors.



218. Disconnect the outside air temperature sensor connector from the right hand side air deflector.



219. Install the provided grommets in the holes of the provided LTR mounting bracket. The grommet on the left is shown installed.





220. Mount the provided LTR stabilizing bracket to the two existing tabs at the lower radiator mounting frame as shown, the flange with the grommets is oriented up and angled forward. Torque the provided mounting fasteners to 80 in-lbs. Be sure to incorporate the provided washers between the fastener head and plastic frame.

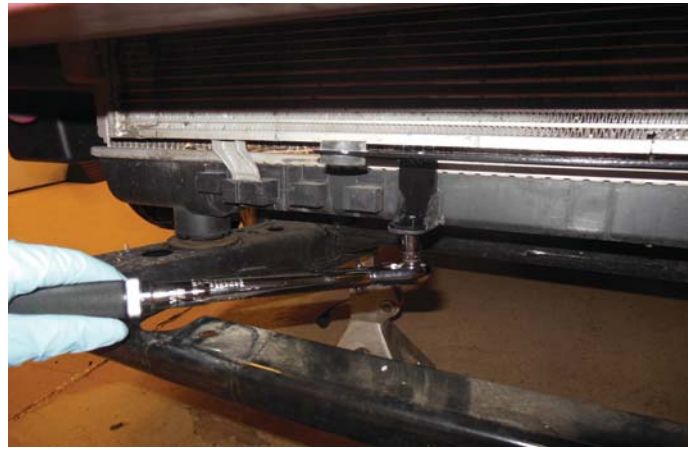

221. Remove the right hand side horn mounting bolt using a 10 mm wrench (the horn will stay in place with existing clips) and replace incorporating the provided intercooler pump bracket to the right hand side lower horn mounting bolt, add the provided bolt and nut at the hole in the forward flange of the mounting frame as shown. Torque the OEM mounting fastener and the provided nut/bolt to 108 in-lbs.



222. At the bottom of the right hand side, forward corner of the fuse center, mount the provided intercooler relay and fuse mounting bracket with the provided nut using a 10 mm wrench. This view is from inside the right hand side fender looking up at the bottom of the fuse center.



223. Mount the intercooler harness relay to the rear stud of the mounting bracket with a provided nut and secure with a 10 mm wrench; route the trigger wire (yellow) covered in wire loom, down and back behind the fuse center.



224. Install the provided 15A fuse in the fuse center, and mount the fuse center tab to the stud remaining on the mounting bracket using the provided nut and secure with a 10 mm wrench.



225. Remove the cover of the fuse center. Remove the nut of the positive terminal at the forward, fender side of the fuse center with a 13 mm socket and install the eyelet terminal of the red wire from the fuse box of the intercooler pump relay.



226. Earlier you routed an EVAP breakout harness wire over to the right hand side of the engine. This is the “trigger” wire for the intercooler pump. Route this wire down along the main wire harness “Y”, behind, up toward the fuse center. Secure this harness to the existing harness with the provided cable ties as shown.



227. Connect the yellow wire from the relay of the intercooler pump harness to the “trigger” wire you routed up from the EVAP break-out harness earlier just behind the fuse center. Secure using a provided zip tie to the adjacent factory harness.





228. Route the remaining harness down and forward of the radiator overflow and connect the ground wire of the harness to the remaining stud on the intercooler pump mounting bracket just below the horn at the right hand side, forward of the wheel well. Secure in place with a provided nut and 10 mm wrench. Torque to 108 in-lbs. Verify your torque wrench settings.



229. Secure the provided intercooler reservoir mounting bracket to the right hand side upper fan shroud mount using the provided 16mm long bolt. Secure with 10 mm wrench. Do not reuse the factory mounting fastener.



230. Mount the provided intercooler reservoir bottle to the just secured mounting bracket using the provided fasteners and secure with 10 mm wrench.

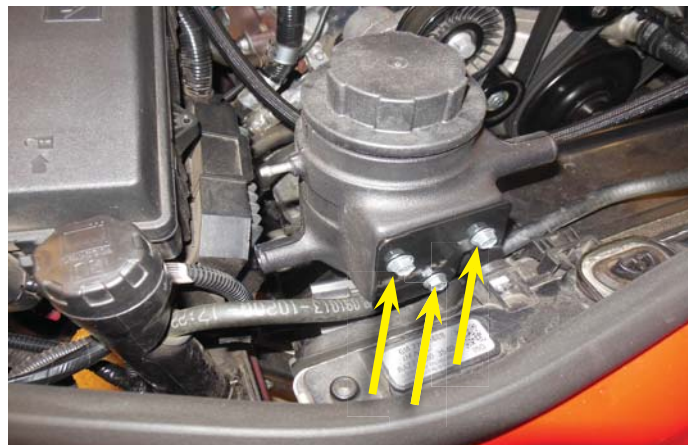

231. Apply the provided sticky-back foam strips to the back-side of the Low Temperature Radiator (LTR) by pulling off the paper shields and pressing in place.

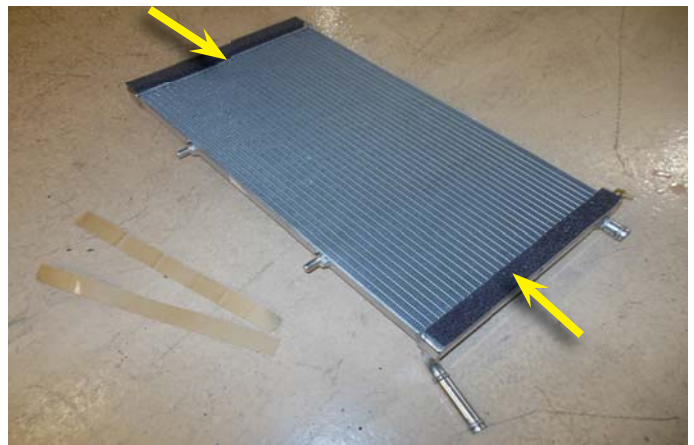

232. Attach the provided overflow hose to the overflow barb on the top of the LTR, securing in place with a provided spring clamp. Ensure that the hose is pointing in the direction shown.

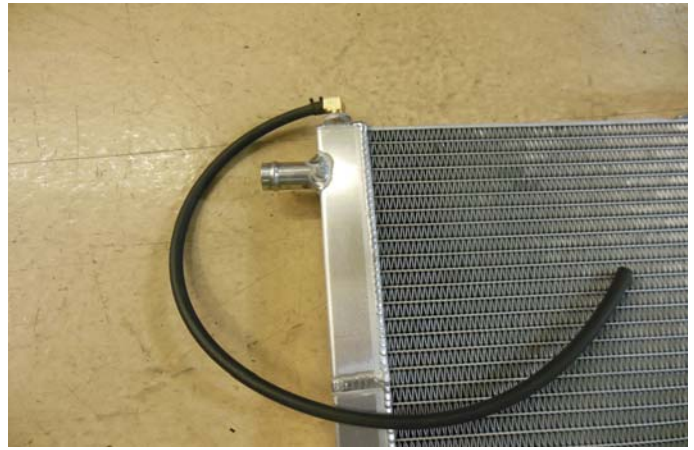

233. On the right hand side vertical flange of the lower radiator air deflector, drill a 1-1/2" hole using a hole saw, 1-1/2" from the inside of the forward bend, and 2-3/8" from the bottom bend as shown. Install the provided grommet in the hole and re-mount using the OEM rivets to the vehicle.

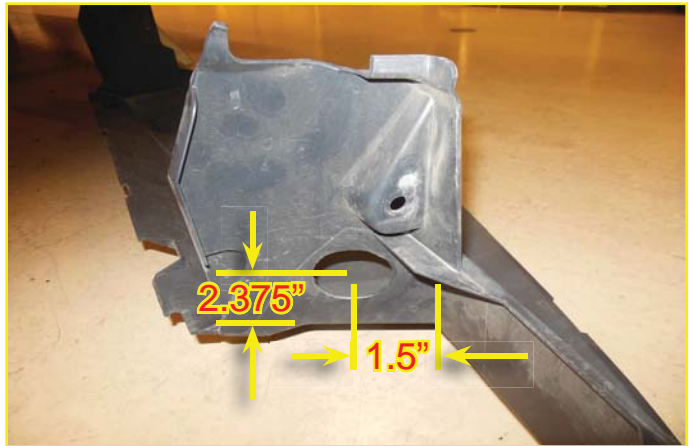

234. These are the intercooler connecting hose assemblies.



235. From the front of the vehicle on the right hand side, slide the long end of the "Reservoir to Intercooler Pump" hose down to the inside of the splash shield between the vertical frame and radiator into the engine compartment with the end containing the short 90° elbow hose section at the top. Rotate the upper end of that 90° elbow section into the engine compartment as well, below the radiator reservoir overflow tank hose and secure to the intercooler reservoir lower hose barb using a provided worm gear clamp. It's important to utilize only worm gear clamps on the reservoir plastic hose barbs.





236. Just below the 90° elbow you just connected, route the elbow end of the “Upper LTR to Supercharger” hose out through the opening between the radiator and the vertical frame.



237. Rotate the hose so that the “J” bend now runs parallel with the front of the existing radiator as shown.



238. Lower the LTR down in front of the radiator and press the bottom mounting tabs into the grommets of the LTR mounting bracket. The lower spigot of the LTR should pass through the hole/grommet of the vertical flange of the lower air deflector.

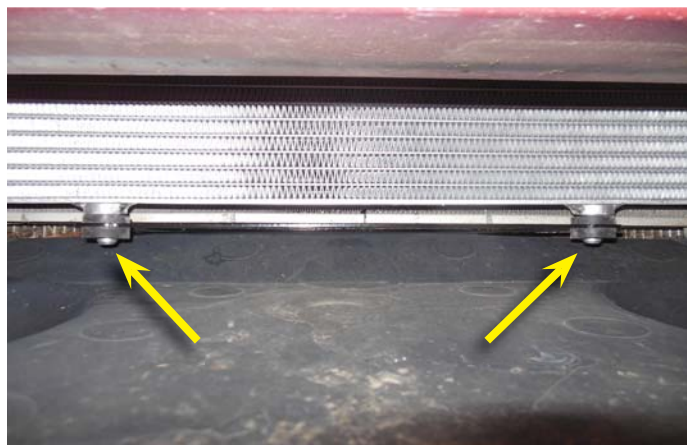

239. Route the overflow hose from the LTR above the hoses just installed into the engine compartment.



240. Use a provided spring clamp to secure the “Upper LTR to Supercharger” hose 90° elbow of to the upper hose barb on the LTR. Orient the tabs of the spring clamp downward.

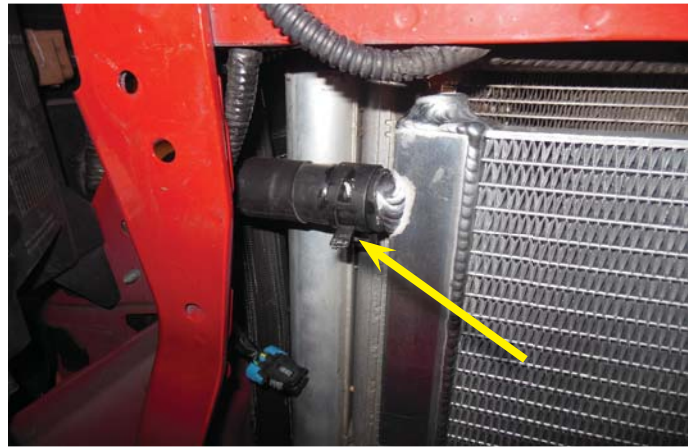

241. Connect the upper mounting bracket of the LTR to the cross frame with the provided bolts, secure in place using 12 mm socket and torque wrench, torque to 18 ft-lbs.



242. Connect the fitting end of the “Upper LTR to Supercharger” hose to the upper hose barb on the Charge Air Cooler (CAC) manifold. Ensure the connection snaps in place securely. It will help the fitting slide in place if you apply a small amount of Lubriplate lubricant (O-ring grease) to the CAC spigot first.



243. Connect the end of the “Reservoir to Supercharger” hose without the fitting to the upper (inside) hose barb on the reservoir using a provided worm gear clamp. Again, it’s important to utilize only worm gear clamps on the reservoir plastic hose barbs.





244. Connect the fitting of the “Reservoir to Supercharger” hose to the lower hose barb on the CAC manifold, again ensure the hose clamp snaps into position securely.

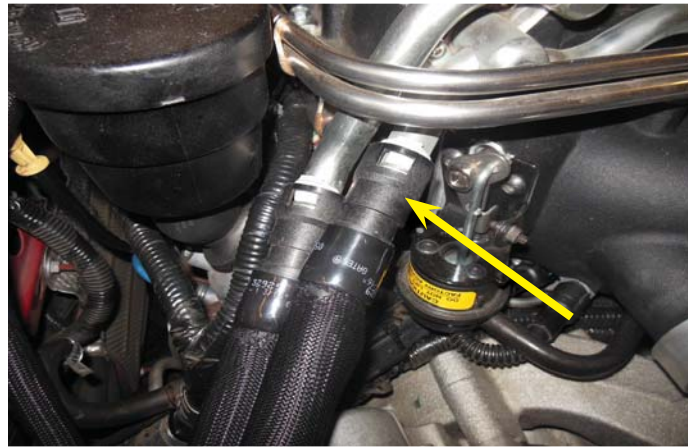

245. Connect the free end of the LTR overflow hose to the metal barb on the reservoir bottle using a provided spring clamp. You may need to trim the hose to route as shown, secure in place with a zip tie where indicated with blue arrow.



246. Slide the provided intercooler pump onto the pump mounting bracket installed earlier with the hose barbs pointing forward, and out toward the right hand side fender as shown. The metal tabs of the bracket should sit flush with the back side of the rubber isolator.



**Note: If you have an optional brake duct system you will have to modify it to make clearance for the intercooler pump.**

247. If you have the optional brake duct system you will need to cut the duct where shown with the yellow line to make room for the intercooler pump and hoses.

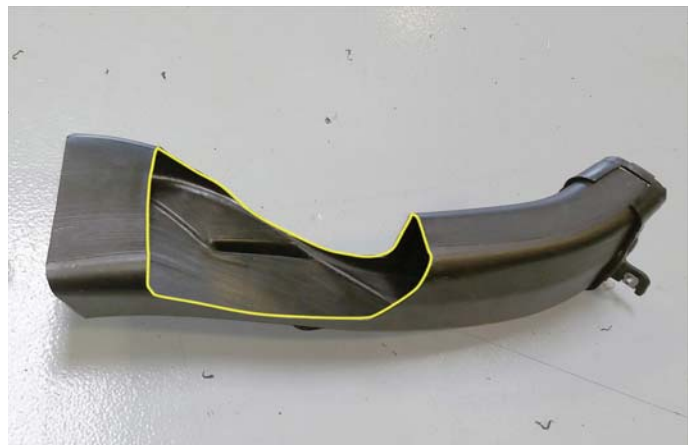

248. Here you can see the modified duct in place with the pump located.



249. Connect the intercooler pump harness terminal to the pump, ensure it snaps into position. It may take some force to get the connector to click into place.

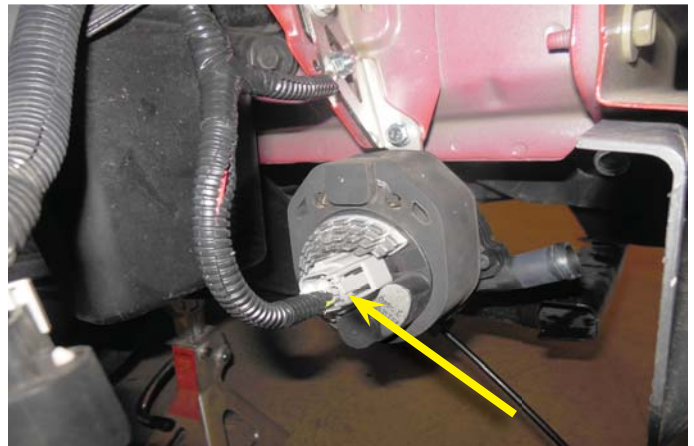

250. Connect the 90° elbow of the “Reservoir to Intercooler Pump” hose to the inlet hose barb on the intercooler pump and secure in position with a provided spring clamp.



251. Use provided zip-ties to secure your hoses to adjacent components, making sure that hoses cannot migrate into moving components.

**DO NOT OVERTIGHTEN cable ties, they are to secure movement NOT COMPRESS.**





252. Connect the short end of the provided 6.5" by 2.5" length 90 degree hose to the intercooler pump discharge hose barb using a provided spring clamp. Route the long end of the hose to the lower LTR hose barb with a provided spring clamp.

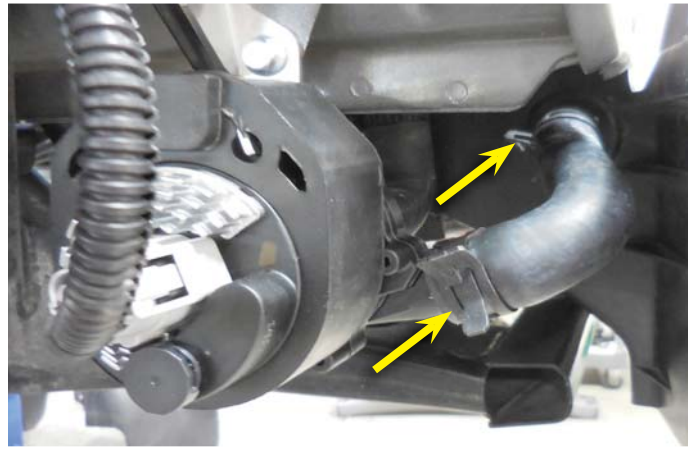

253. Mark the back side of the right hand side air deflector for a notch to accommodate the new LTR upper hose barb. Cut this section out to have clearance for the LTR hose barb.

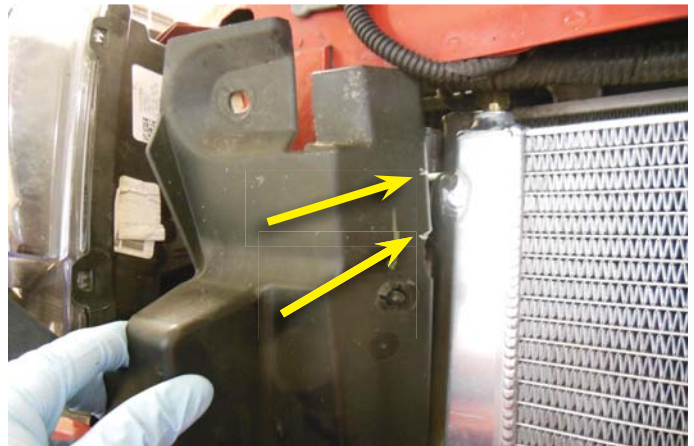

254. Reconnect the outside air temp harness to the sensor on the right hand side air deflector.



255. Remount both side air deflectors using the OEM fasteners.

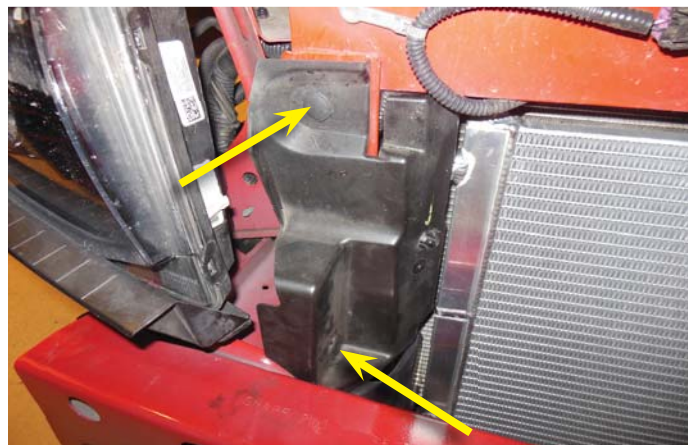

256. Reconnect the battery negative terminal in the trunk and replace the associated covers reversing the removal steps.



**Make sure that you have followed step #1 in this manual to load the proper supercharger calibration to your vehicle's ECM.**

## Section 14: Body Panel Installation, and Final Inspection

257. Ensure the petcock is closed prior to re-filling the engine coolant. Place rags around the filler opening. Filter factory coolant that was drained in an earlier step and pour into the reservoir tank if it is re-usable. Otherwise pour the new coolant according to the manufacturer's specifications. Squeeze the radiator hoses to help relieve air in system. Install the cap once the coolant reservoir has been filled. You may need to top it off after the engine has run for the first time.
258. Fill your intercooler system with the GM recommended coolant mixture. To check for leaks prior to re-installing fascia/grille, temporarily reconnect the battery and key the car to "Accessory" position.

**DO NOT START YOUR ENGINE.**

**\* NOTE: The pump will slowly spool up once it has power. It may take 5-10 seconds before you notice flow.**

259. Reinstall the fascia/grille components reversing the removal process using the OEM fasteners.

**Refer to the owners manual for proper torque order and specifications under Vehicle Care, and Technical Data sections.**

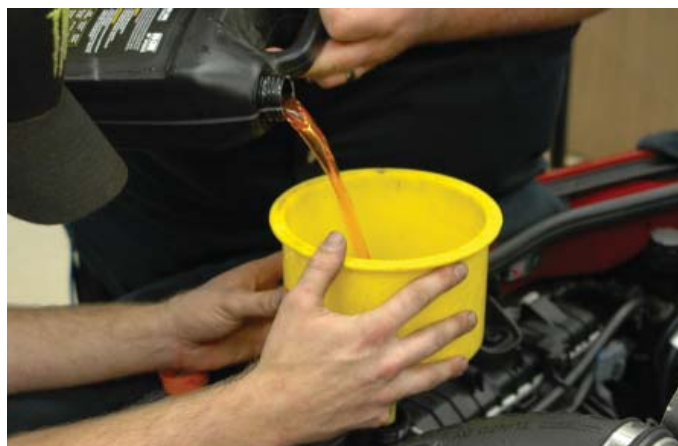



260. Reinstall the wheel well liners using the factory fasteners.



261. Torque wheels after installation.

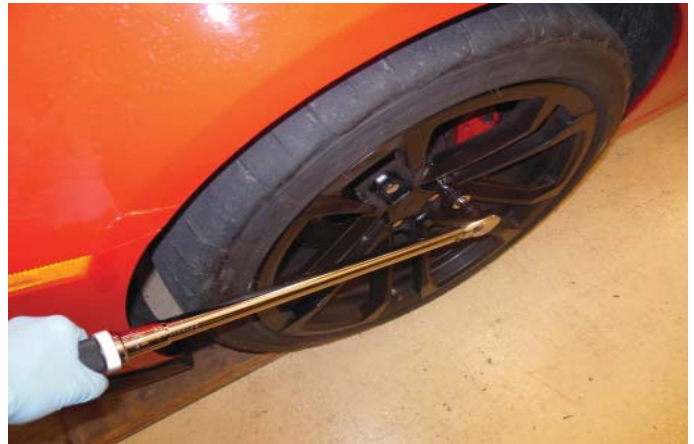

262. Reinstall the strut tower brace, if equipped, and torque to 18 ft-lbs.



263. Start your engine checking for leaks and listening for any unusual sounds or vibrations. There will be a slight whining as the rotors spin. This is a normal sound. Listen for any knocking or pinging (detonation). This vehicle requires 91 octane gasoline fuel and any residual lower octane fuel can create detonation. Run your engine for 5 minutes and shut down. Check your inter-cooler reservoir, and radiator and top off as necessary.



264. Affix the routing diagram to the underside of the hood for reference.



265. Affix the octane requirement fuel sticker to the inside of the fuel door as reference.

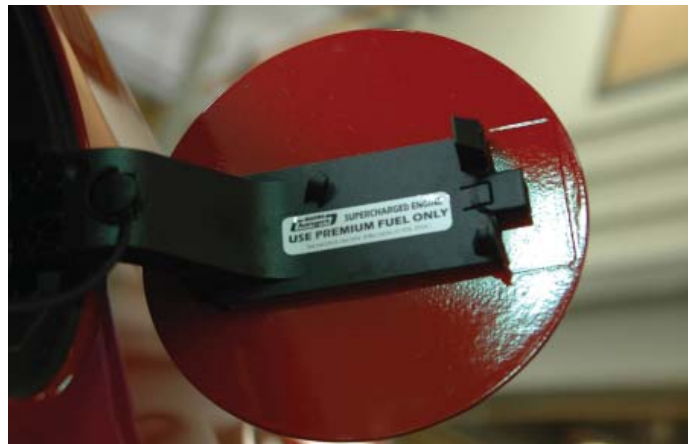

266. Test drive vehicle for the first few miles under normal driving conditions. **Do not perform any wide open throttle runs.** Listen for any noises, vibrations, engine misfire or anything that does not seem normal. The supercharger does have a slight whining noise under boost conditions, which is normal. Check & bleed the charge air cooler reservoir as needed. After the initial test drive gradually work the vehicle to wide open throttle runs, listen for any engine detonation (pinging). If engine detonation is present let up on the throttle immediately. Most detonation causes are low octane gasoline still in the tank.



**\* Use only premium gasoline fuel, 91 octane or better. \***

**ATTENTION!**  
**Your MAGNUSON SUPERCHARGER kit**  
**is sensitive to corrosion!**  
**Use only the vehicle manufacturer recommended coolant**  
**for your engine in the intercooler system as well.**

If you have questions about your vehicles performance, please check with your installation facility.



# Appendix

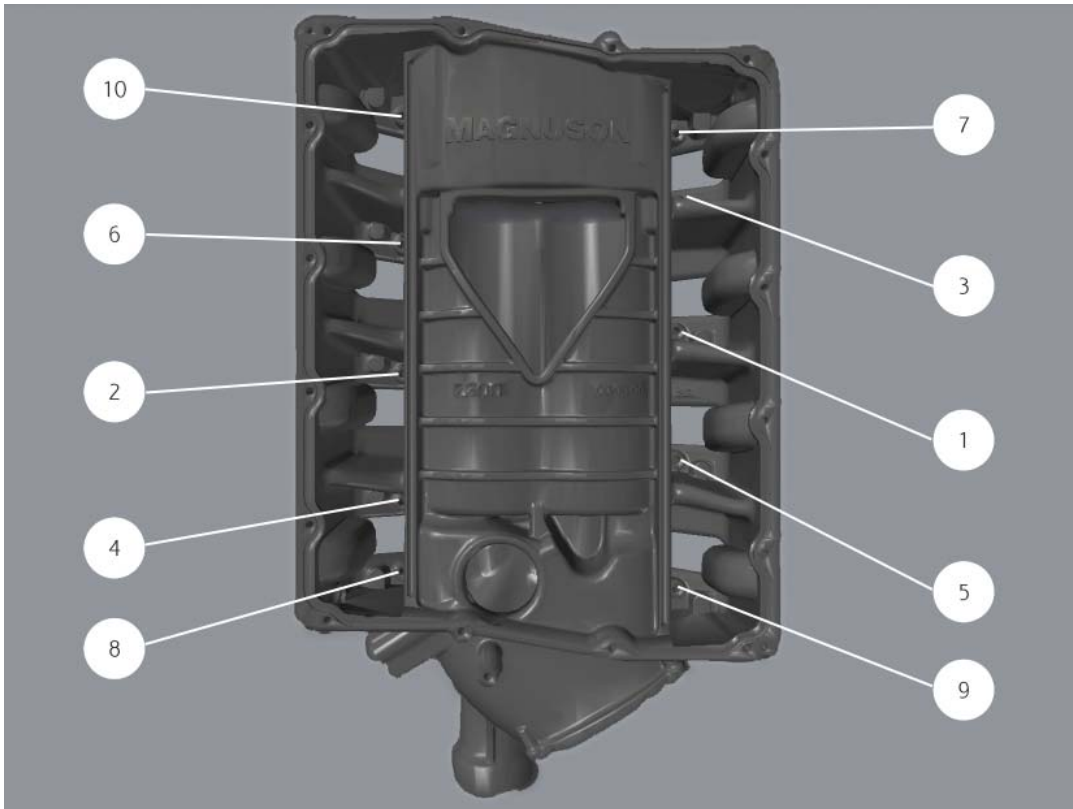

## Supercharger Torque Sequence

# Appendix

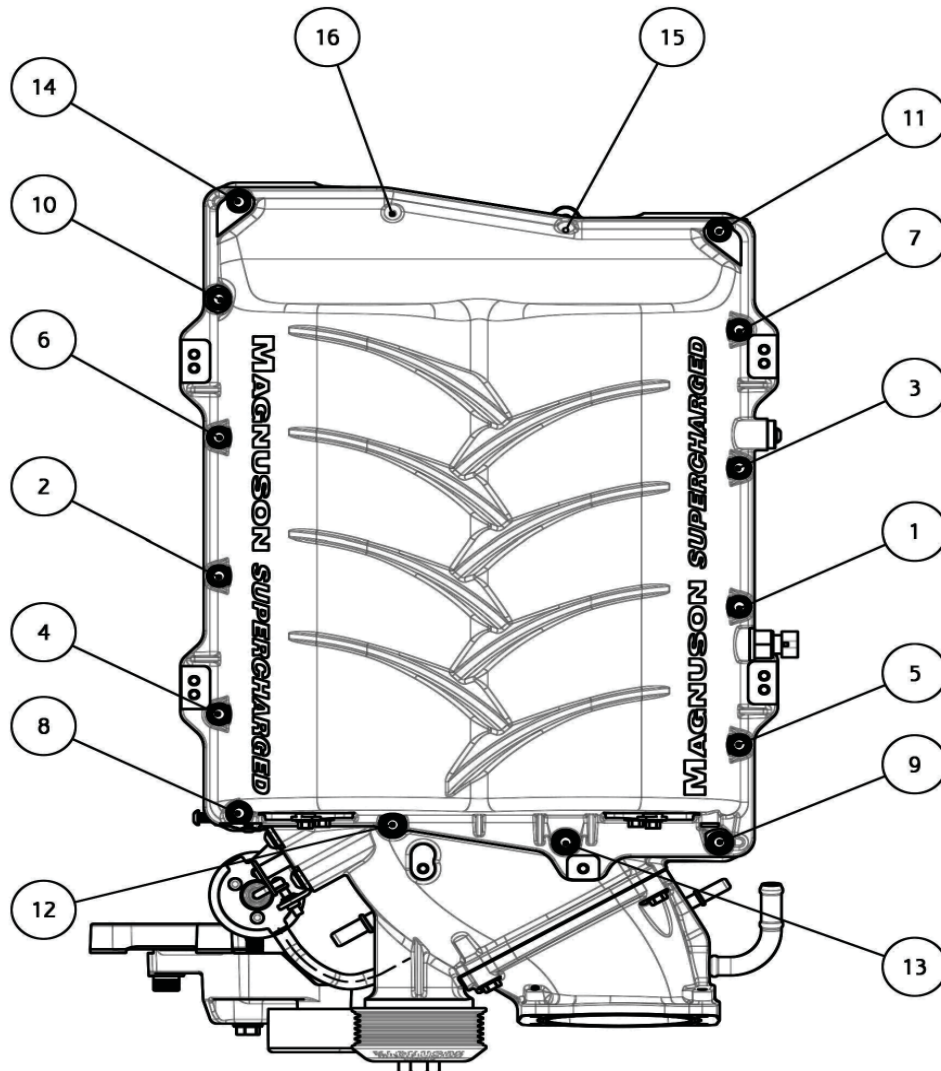

## Lid Torque Sequence

Fastener Length

20mm: 9, 10, 11, 12, 13, 14 (9-14)

25mm: 15, 16

50mm: 1, 2, 3, 4, 5, 6, 7 (1-7)

60mm: 8



# Appendix

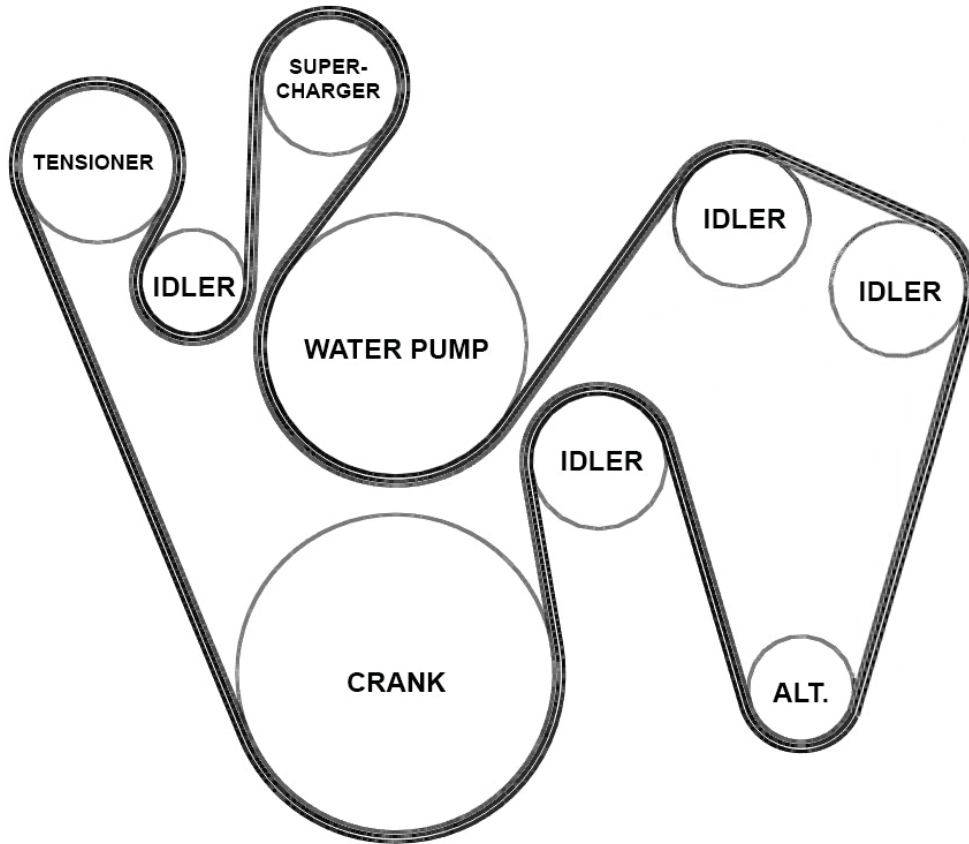

**Belt Routing Diagram**

# Notes



# Notes



Please enjoy your Magnuson Super  
Charged performance responsibly.

**MAGNUSON**  
*SUPERCHARGERS*