



Instructions for:

Track Heat Intake Manifolds for 429/460 Ford

TFS-53400111 (4150 Flange) & TFS-53400112 (4500 Flange)

Thank you for purchasing the Trick Flow Track Heat Intake Manifold for 429/460 Ford engines. This manifold is designed for street/strip applications that operate in the 3,500-8,000 rpm range and require either a Holley 4150 or 4500-style 4-barrel carburetor depending on which manifold you have purchased.

Recommended Components:

- Permatex # 16B Black Silicone Adhesive Sealant
- Fel-Pro # 1230 Printoseal intake manifold gaskets (TFS-53400111)
- Trick Flow # TFS-53400921 intake manifold gaskets (TFS-53400112)

Installation Procedure:

- 1.) Thoroughly clean the gasket surfaces on the cylinder heads and the block end rails.
- 2.) Run a 1/4" - 5/16" bead of silicone adhesive sealant along the end rails.
- 3.) Outline the water openings on the cylinder heads with silicone adhesive sealant to prevent potential leaks between the cylinder heads and the gasket. This will also help keep the gaskets in place while installing the manifold.
- 4.) Place the intake manifold gaskets on the heads.
- 5.) Place a small amount of silicone adhesive sealant on the end rails of all four corners where the intake manifold gaskets and end rails intersect.
- 6.) Install the intake manifold by carefully lowering it onto the gaskets.
- 7.) Thread the bolts in and begin tightening them while keeping an eye on the gaskets to make sure that they stay in place.
- 8.) Torque the manifold bolts in the following steps, using the sequence below. A.) 16 ft. lbs., B.) 22 ft. lbs, C.) 30 ft. lbs.
- 9.) After initial start-up, check for leaks.

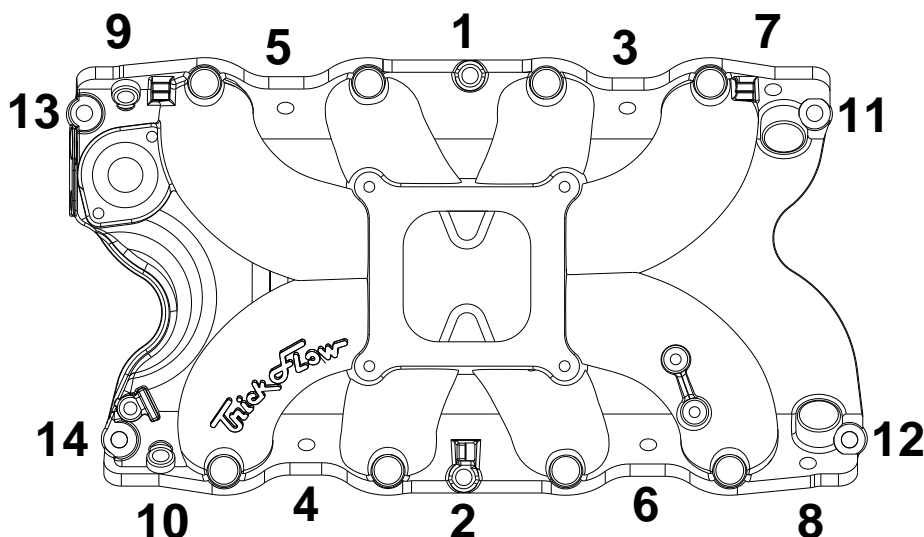

Ultimate Bolt-On Performance® Lifetime Warranty

Trick Flow Specialties cylinder head castings are backed by a lifetime warranty. If a cylinder head casting fails to provide the original purchaser with complete satisfaction, Trick Flow Specialties will repair or replace it free of charge — guaranteed!

Moreover, the valves, valve guides, valve seats, valve job, valve springs, valve spring retainers, valve locks, rocker arm studs, guideplates, and valve stem seals included on assembled Trick Flow Specialties cylinder heads are warranted to the original purchaser to be free from defects in materials and workmanship for a period of two years from the date of purchase. All other Trick Flow Specialties products are warranted to be free from defects in materials and workmanship for a period of 90 days. There are no mileage limitations.

Extent of Warranty

Customers who believe they have a defective product should return it to the dealer from which they purchased or ship it freight prepaid to Trick Flow Specialties along with proof of purchase and a complete description of the problem. If a thorough inspection indicates defects in materials or workmanship, our sole obligation is to repair or replace the product.

This warranty is only if the product is properly installed, subjected to normal use and service, did not fail due to owner negligence or misuse, and has not been altered or modified.

Trick Flow Specialties warranties do not cover any installation or removal costs.

Trick Flow Specialties is not liable for consequential damages for breach of contract of any warranty in excess of the purchase price of the product sold.

PROPOSITION 65 WARNING

This product may contain one or more substances or chemicals known to the state of California to cause cancer, birth defects or other reproductive harm.

TRICK FLOW SPECIALTIES
285 WEST AVE.
TALLMADGE, OHIO 44278
(330) 630-1555

