

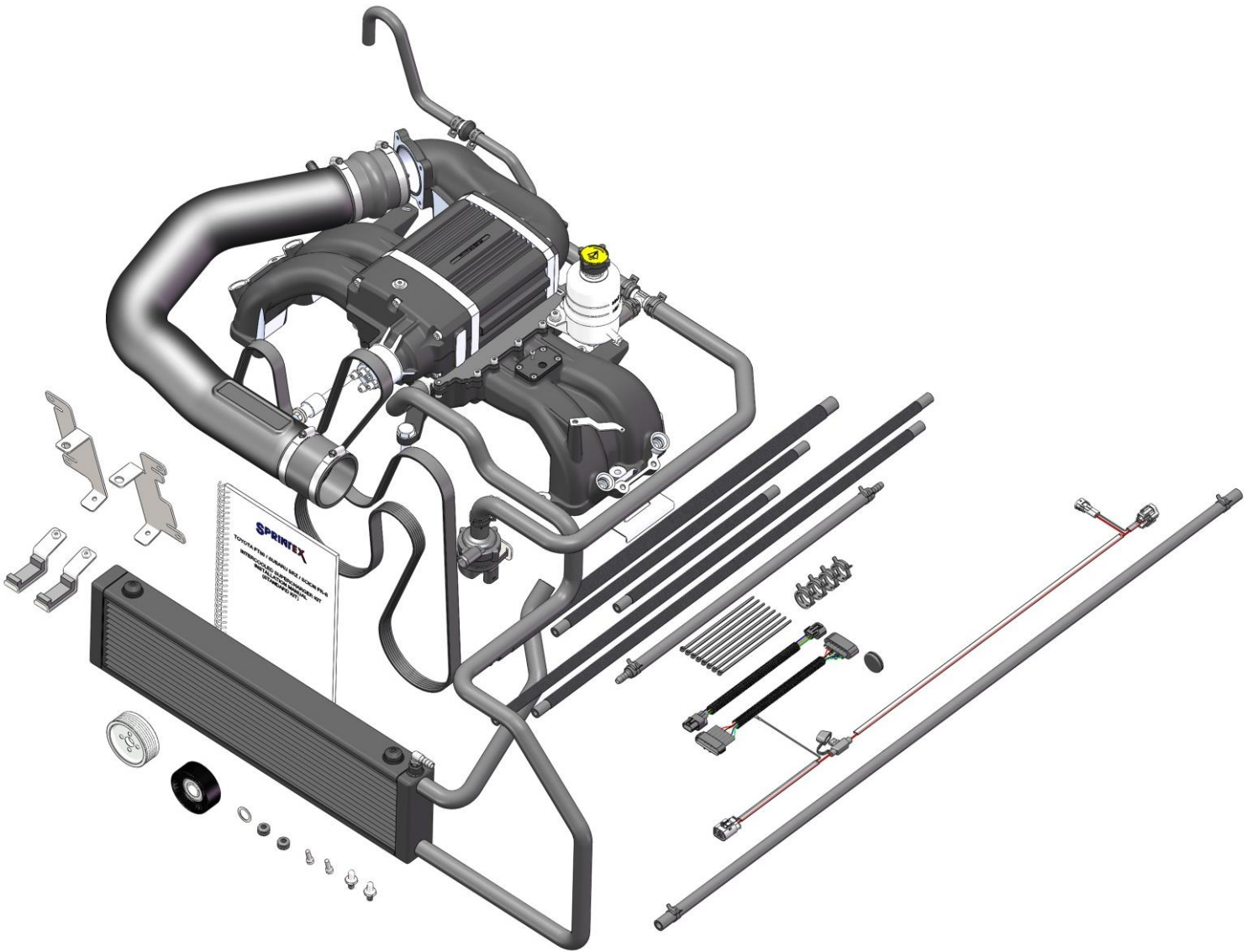

# TOYOTA 86 / SUBARU BRZ / SCION FR-S SUPERCHARGER SYSTEM



## INSTALLATION INSTRUCTIONS



# **TABLE OF CONTENTS**

<b>INTELLECTUAL PROPERTY USED IN THIS PUBLICATION</b> .....	<b>- 4 -</b>
<b>IMPORTANT INFORMATION / PRODUCT WARNING</b> .....	<b>- 5 -</b>
<b>CHANGES TO FACTORY SPECIFICATIONS</b> .....	<b>- 7 -</b>
<b>TOOLS AND CONSUMABLES REQUIRED TO COMPLETE INSTALLATION</b> .....	<b>- 8 -</b>
<b>PARTS SUPPLIED</b> .....	<b>- 8 -</b>
<b>DISASSEMBLY INSTRUCTIONS</b> .....	<b>- 9 -</b>
<b>PREPARATION</b> .....	<b>- 9 -</b>
1. Disconnect battery .....	- 11 -
2. Disconnect inlet pipe .....	- 11 -
3. Remove inlet manifold cover.....	- 11 -
4. Disconnect hoses.....	- 12 -
5. Disconnect MAP sensor.....	- 12 -
6. Disconnect throttle body .....	- 12 -
7. Disconnect harness from manifold.....	- 13 -
8. Remove Injector covers .....	- 13 -
9. Disconnect fuel rail support.....	- 14 -
10. Disconnect injector harness.....	- 15 -
11. Remove Under Tray.....	- 16 -
12. Remove Front Bumper.....	- 17 -
13. Disconnect heater hoses .....	- 19 -
14. Remove manifold .....	- 19 -
15. Remove the EVAP solenoid.....	- 20 -
16. Remove the sound pipe .....	- 20 -
17. Replace brake booster hard line .....	- 21 -
18. Remove strut braces .....	- 21 -
<b>INSTALLATION INSTRUCTIONS</b> .....	<b>- 22 -</b>
19. Install the engine breather hose.....	- 23 -
20. Install throttle body heater hoses .....	- 23 -
21. Install EVAP solenoid.....	- 24 -
22. Install throttle body loom extension.....	- 24 -
23. Attach the MAP sensor loom extension .....	- 25 -
24. Attach wiring harness relocation bracket (Automatic Transmission Only).....	- 25 -
25. Water pump installation .....	- 26 -
26. Install the Intercooler hoses .....	- 27 -
27. Intercooler radiator installation.....	- 29 -
28. Install idler pulley.....	- 30 -
29. Install vacuum fittings.....	- 30 -
30. Install fuel rails .....	- 31 -
31. Test fit the supercharger manifold .....	- 32 -
32. Attach throttle body connector .....	- 33 -
33. Install supercharger pulley .....	- 33 -



34. Attach heater hoses .....	- 33 -
35. Install drive belt .....	- 34 -
36. Connect fuel supply line .....	- 34 -
37. Attach MAP sensor connector .....	- 35 -
38. Connect intercooler hoses .....	- 36 -
39. Fit breather hoses .....	- 37 -
40. Fit the inlet pipe .....	- 38 -
41. Reinstall the strut braces .....	- 38 -
42. Modify bonnet (hood) insulation .....	- 39 -
43. Refill the cooling system .....	- 40 -
44. Refit Front Bumper .....	- 40 -
45. Reconnect battery .....	- 40 -
<b>PRE TEST-DRIVE INSPECTION .....</b>	<b>- 42 -</b>
46. Pre-start inspection .....	- 43 -
47. Engine warm up .....	- 43 -
48. Road test vehicle .....	- 43 -
<b>MAINTENANCE INSTRUCTIONS .....</b>	<b>- 44 -</b>
49. Supercharger drive belt replacement .....	- 45 -
50. Supercharger gearbox oil change interval .....	- 46 -
51. Supercharger gearbox oil change procedure .....	- 46 -

## **INTELLECTUAL PROPERTY USED IN THIS PUBLICATION**

This document is copyright of Sprintex Ltd, a company incorporated in Australia. This document may not be re-sold, copied or distributed in any way without prior written authorisation of Sprintex Ltd.

### **Copyrights / Trademarks:**

Sprintex® is a registered trademark of Sprintex Limited, an Australian company ACN: 106 337 599 (“Sprintex”). Sprintex has patents for its superchargers. Any unauthorised copying or modification of the system may result in legal action.

Loctite® and Grey Maxx® are registered trademarks of Henkel KGaA, a company incorporated in Germany. Other than commercial supply arrangements, Henkel KGaA does not have any association with Sprintex.

RedLine® is a registered trademark of RedLine Synthetic Oil Corporation, a company incorporated in the United States of America. Other than commercial supply arrangements, Redline and RedLine Synthetic Oil Corporation do not have any association with Sprintex.

Toyota 86, Subaru BRZ & Scion FR-S are registered trademarks of Toyota, Subaru & Scion Companies

SAE is a trademark of SAE International ([www.sae.org](http://www.sae.org)) an international technology, information and standards setting resource organisation for the design, manufacturing, operation, and maintenance industry.

Gates is a registered trademark of the Gates Rubber Company, a subsidiary of Tomkins PLC, incorporated in London, United Kingdom. Other than commercial supply arrangements, Gates and Tomkins PLC do not have any association with Sprintex Limited.

## IMPORTANT INFORMATION / PRODUCT WARNING

Should you have purchased a Sprintex Supercharger System (Part No 265A1001) or Upgrade Kit (Part No 265A1003) equipped with a S5-335 supercharger please note the following:

The Sprintex S5-335 supercharger system is not suitable for installation on standard or stock FT86/FRS/BRZ vehicles and is not intended for use on public roads. This system is intended to be used on professionally modified FT86/FRS/BRZ vehicles being used for motorsports purposes only. For warranty conditions relating to this system, please refer to the Sprintex Limited Warranty Document provided with the system and/or available on the Sprintex website.

Installation of the Sprintex Supercharger system on a Toyota 86, Subaru BRZ & Scion FR-S vehicles may void all or parts of Toyota, Subaru & Scion Warranties. Customers should consult their dealer for details.

Sprintex makes no representation that installation and use of the Sprintex supercharger system is legal for public road use worldwide. Customers should check that installation and use of the Sprintex supercharger system on their vehicle is legal by contacting the relevant statutory authority in their jurisdiction prior to use on roads.

Sprintex supports safe driving. So always remember to observe all speed limits and road rules relevant to the state, city or other local jurisdiction.

Provided in this installation manual are detailed instructions to the installer on how to install the Sprintex patent pending supercharger system to the Toyota 86 / Subaru BRZ / Scion FR-S vehicles (the vehicle). The instructions are aimed at being simple yet informative, and are aided with well-presented pictures to make installations as simple, fast and problem free as possible. **Please read the entire instruction manual prior to beginning the installation procedure.** Pictures and descriptions may vary slightly from model to model.

It is recommended that all wiring harness connectors and vacuum hoses are labelled at the time of removal for easy and correct refitting. Some components that are removed and are to be refitted are fragile, and should be stored safely to prevent damage to these components.

- Sprintex recommends performing the following vehicle checks prior to installing the supercharger:
- Check that the factory fuel system is operating correctly.
- Ensure that the vehicles ignition system is working correctly.
- Inspect the catalytic converters for blocks or damage.
- Replace the fuel filter if the vehicle has travelled more than 15,000 Km or 9000 miles.

Sprintex will not be liable for any loss, damage, payment, costs, expenses or other liability not expressly stated in this document. In particular Sprintex shall not be liable to any person for any consequential, indirect or economic loss, punitive or exemplary damages of any kind.

Sprintex reserves the right to change specifications from time to time and will not be liable to any person for doing so. Sprintex believes that the information in this document is correct at the time of print. Sprintex

limits its liability to the maximum extent permissible at law with regard to the reliance which any person places on anything in this document.

This Sprintex supercharger installation requires that the vehicle be fitted with an approved ECU and ECU calibration. Failure to ensure this will affect the performance and may void the warranty. Contact your reseller to confirm if necessary.

**California residents:**

California Proposition 65 entitles California to special warnings for products that contain chemicals known to the state of California to cause cancer and birth defects or other reproductive harm.



**WARNING**

This product can expose you to chemicals including Cumene, which is known to the State of California to cause cancer or birth defects or other reproductive harm.

For more information, visit

[www.P65Warnings.ca.gov](http://www.P65Warnings.ca.gov).

## **CHANGES TO FACTORY SPECIFICATIONS**

**FUEL:** Minimum 98 RON (91 Octane USA) premium unleaded gasoline / fuel to be used at all times. Never allow the engine to knock or detonate as serious engine damage may occur.

**SERVICING REQUIREMENTS:** (See maintenance section of manual)

Inspect the supercharger drive belt at every routine service and replace if required.

Drain and replace supercharger oil every 50,000 km or 30,000 miles. Use a quality fully synthetic SAE 75W-90 gear oil, specifications: API GL5, MT1 such as: Redline 75W90 NS gear oil (factory fill), Castrol Syntrax Universal Plus 75W-90, Lucas synthetic SAE 75W-90 gear oil or equivalent. It is critical not to overfill the supercharger gearbox as damage will occur. **Fill with exactly 157 millilitres or 5.31 us fluid ounces.**

Check the oil level with the dipstick provided in the supercharger assembly. Tighten the dipstick fully before checking the oil level.

### **NOTE:**

Many of the photos shown in this document are of a typical Toyota 86 right hand drive vehicle and are similar to a typical Toyota 86 left hand drive vehicle.

Some of the terminology and language used in this instruction may vary from that of the end user / installer's expectations, as some tools and automotive components have different common names in different geographical locations.

## TOOLS AND CONSUMABLES REQUIRED TO COMPLETE INSTALLATION

- Metric Wrenches and Socket Set
- Flat and Philips Screwdrivers
- Various Pliers and Side Cutters (Dykes)
- Rubber grease or white petroleum jelly
- Metric Allen Keys

## PARTS SUPPLIED

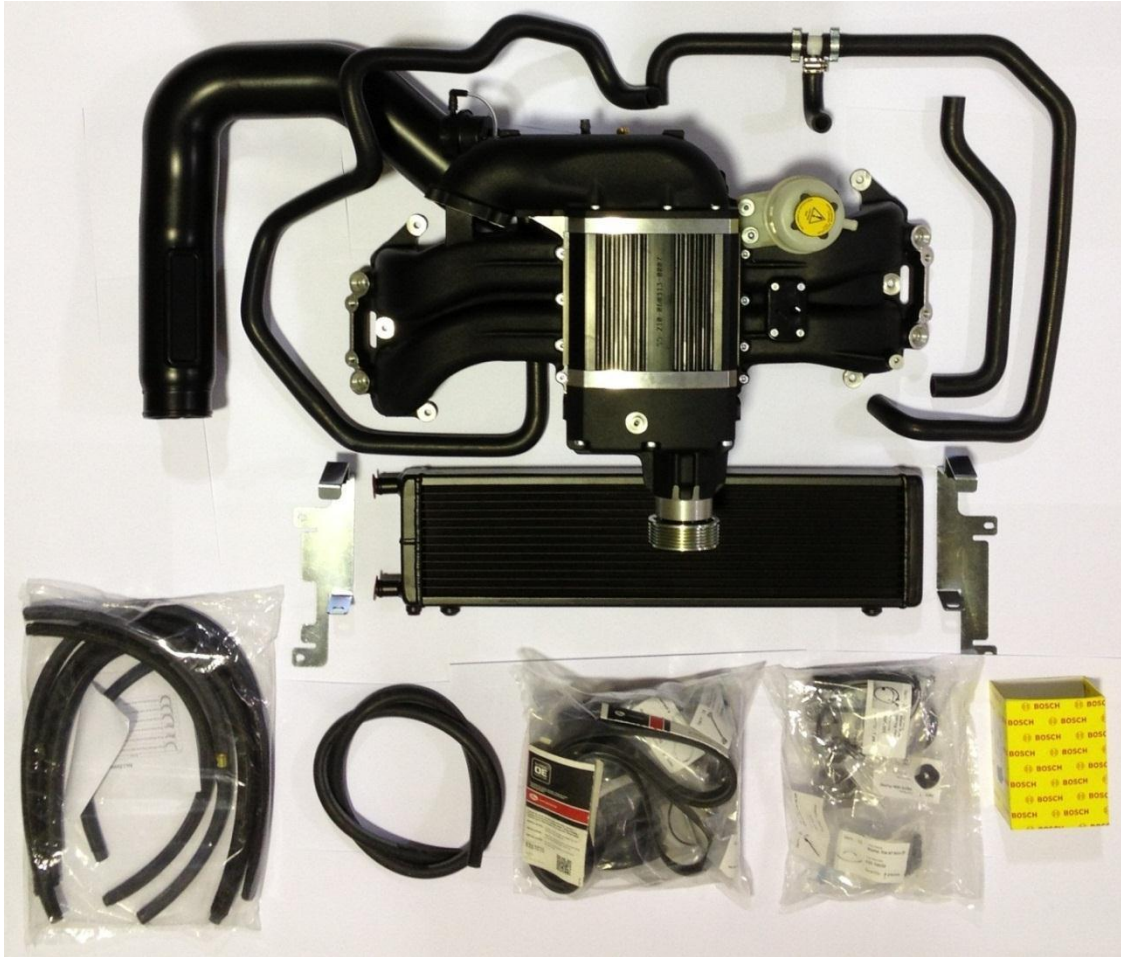

- Sprintex® Supercharger manifold assembly
- Inlet pipe and silicone hose couplers
- Throttle body loom extension
- MAP sensor loom extension
- Idler pulley post, pulley and bolt
- Drive belt
- M14 x 1.5 x 40 hex head bolt
- Supercharger pulley & fasteners
- Manifold flange O-rings
- Throttle body O-ring
- EVAP solenoid bracket & screw
- Ancillary parts
- (option) Intercooler system components
- Radiator mounting brackets
- Installation manual



# TOYOTA 86 / SUBARU BRZ / SCION FR-S SUPERCHARGER SYSTEM

## SECTION 1

### DISASSEMBLY INSTRUCTIONS

#### PREPARATION

Ensure that all components required to assemble the supercharger are available. Refer to the Parts Supplied section provided earlier.

Ensure that all required tools are available.

Please read the entire instruction manual prior to beginning the installation procedure.

Ensure vehicle is located in a secure position with vehicle tyres secured and handbrake applied. To avoid injury Sprintex® recommends the use of a suitable vehicle lift or axle stands when the vehicle is required to be lifted for access. Stands should be positioned as per the vehicle Manufacturers Owners Handbook.

#### SAFETY WARNING

No unauthorised service or alteration may be undertaken to the Sprintex supercharger. Installation should be carried out in a workshop which is a safe and ventilated working environment with equipment and procedures compliant with local authority guidelines and legal requirements. Installers should ensure adequate hearing, eye, and physical protection is used at all times during the installation process. Installers should take reasonable precautions to avoid fatigue and closely follow the installation instructions during every installation. Sprintex recommends installation should not be carried out unsupervised. Sprintex, its directors, employees and agents will not accept liability for damage accident or injury resulting from the installation process. Safety warnings are also provided throughout this document.

Allow engine to cool prior to proceeding with disassembly to prevent scalding.

## NOTES:

- During disassembly and removal of components, take notes and ensure to label and store them safely. This will help with the reassembly process.
- Many of the photos shown in this document are of a typical Toyota 86 right hand drive vehicle and are similar to a typical Toyota 86 left hand drive vehicle.



Left hand drive vehicle



Right hand drive vehicle

- Connect or disconnect battery cables, jumper cables or battery charger only while the ignition is switched off.
- Disconnecting the battery may erase fault codes stored in the control module memory. Using diagnostic equipment, check for fault codes before disconnecting battery cables. If the malfunction indicator lamp (MIL) is illuminated.

- **MIL (Malfunction Indicator Lamp)**

The MIL can be found in one of two locations, dependent on the market the vehicle has been built for.

The MIL may be an illuminated ENGINE symbol within the speedometer cluster.

The MIL may be displayed as SERVICE ENGINE SOON within the tachometer.

Please refer to the OWNERS HANDBOOK to define which of the above applies to the vehicle to be fitted with the Sprintex supercharger kit.

- Always disconnect the negative battery terminal before disconnecting the positive battery terminal. This prevents possible shorting and potential battery damage.

## 1. Disconnect battery

- First, disconnect the negative (-) battery cable.
- Lift the positive (+) terminal plastic cover, then disconnect the positive (+) cable.



## 2. Disconnect inlet pipe

- Disconnect the vacuum hose from inlet pipe.
- Disconnect the MAF sensor connector.
- Loosen the hose clamps and remove the inlet pipe and sound pipe from the vehicle.
- Remove the 3 screws that secure the airbox.
- Remove the air box from the vehicle



## 3. Remove inlet manifold cover

- Gently depress the tab at the front of the cover and lift to remove.



#### 4. Disconnect hoses

- Disconnect the engine breather hose (1) and the brake vacuum hose (2) from the rear of the manifold.
- **Note:** On automatic transmission vehicles there will be a blanking plug in place of the brake vacuum hose. The blanking plug should be retained for use during the reassembly process.

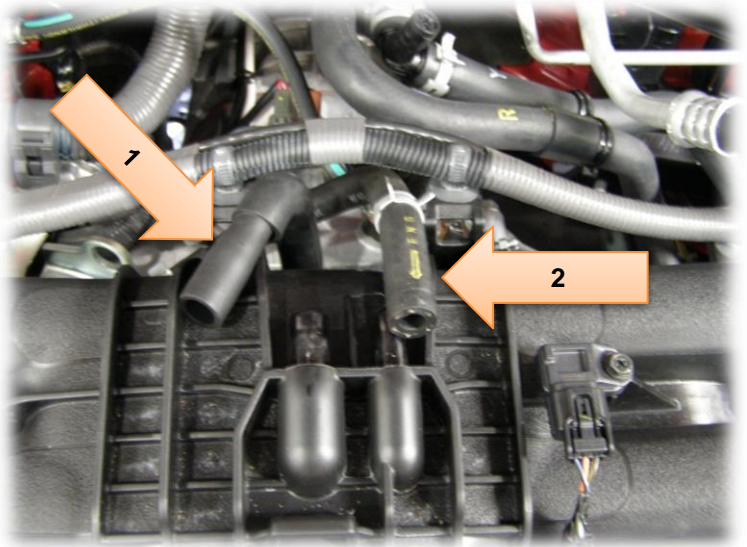

#### 5. Disconnect MAP sensor

- Disconnect the MAP sensor plug.



#### 6. Disconnect throttle body

- Disconnect the throttle body plug.



## 7. Disconnect harness from manifold

- Disconnect the 6 clips retaining wiring harness to the inlet manifold.
- Disconnect the alternator harness from the manifold covers.
- Disconnect the ECU wiring from the back of the left hand injector cover.



## 8. Remove Injector covers

- Disconnect the ECU from the injector cover (x3 screws) and carefully lower the ECU.
- Remove the two screws securing the sound pipe to the left hand injector cover.
- Remove the injector covers from the engine (x2 screws) from both left and right cylinder heads.

**Note:** Removing the Oil filler cap can make removing the right hand injector cover easier, ensure that you replace the Oil filler cap immediately afterwards.



## 9. Disconnect fuel rail support

- Disconnect the EVAP solenoid hose from barb (A).
- Remove the screw from fuel rail support (B)

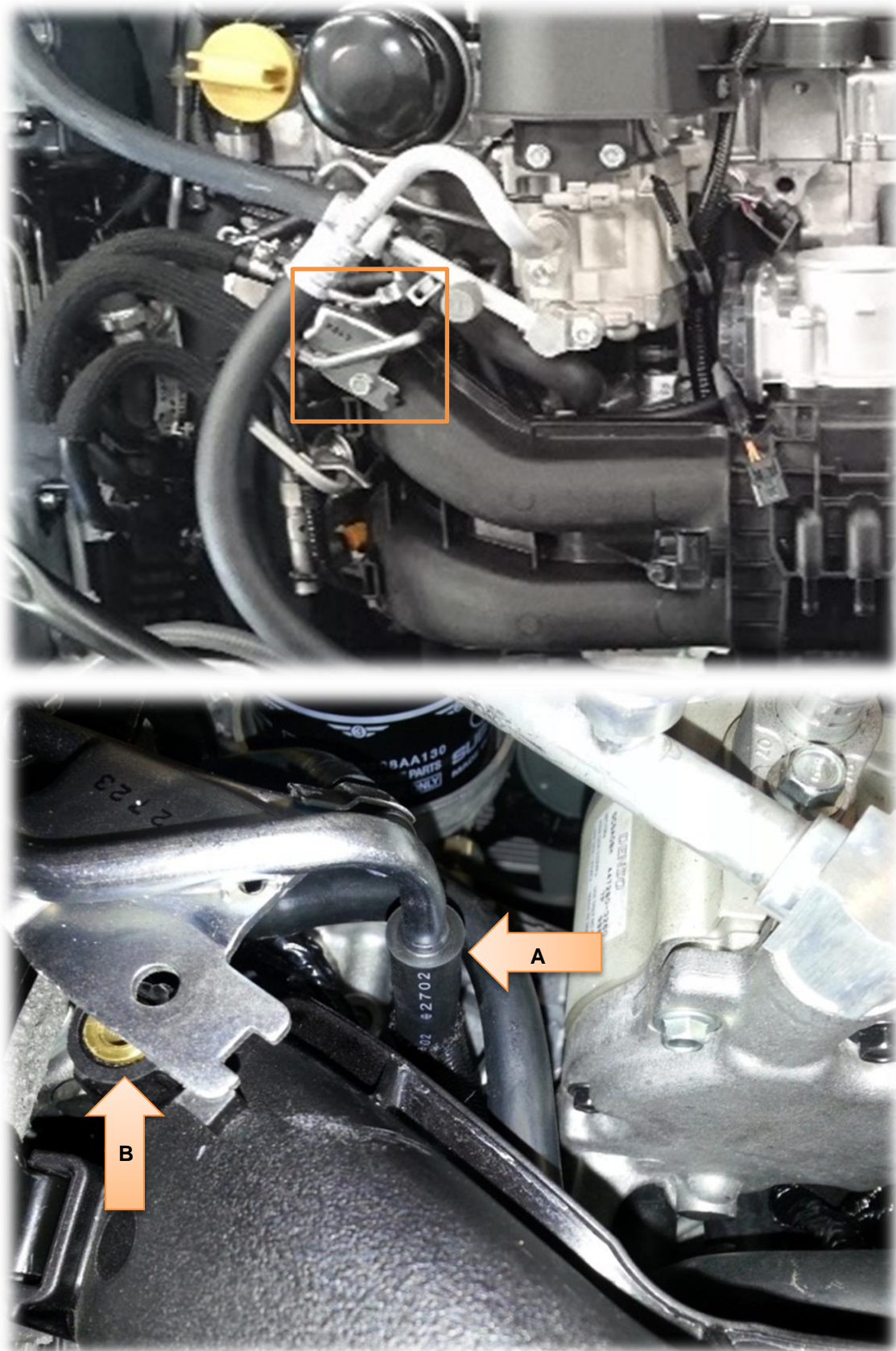

## 10. Disconnect injector harness



- Disconnect the injector plugs from the injectors. Disconnect the connector from the high pressure fuel pump. Unclip the injector harness from the fuel rail on both sides of the engine.
- Carefully disconnect fuel line from the left hand fuel rail.

**Caution:** fuel may still be under pressure and may spray out when the line is disconnected. Wrap a rag around the joint to prevent fuel spillage whilst disconnecting the fuel line.

- Disconnect the EVAP solenoid connector and harness from the manifold (left hand side rear).



## 11. Remove Under Tray

- Jack up car to allow access to the front under body trays.
- Remove the front under body tray retaining bolts  and plastic clips  and remove all three parts of the front under body tray.

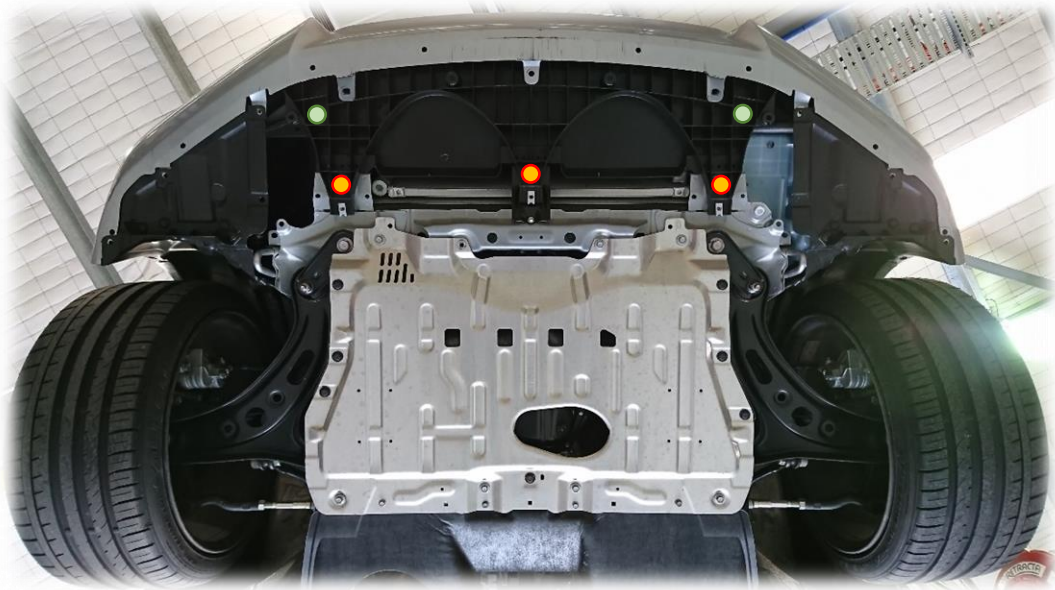



## 12. Remove Front Bumper

- On both sides remove the four plastic clips at the front edge of the wheel arch attaching the arch liner to the bumper



- Carefully pull out the side marker lights which are held into the bumper with 3 metal spring clips and remove the bulb holder. Make sure to push the bulb holder back through the hole in the bumper so it doesn't get caught when removing the bumper.



- With the side marker light removed another plastic clip is visible that secures the top rear most corner of the bumper. Remove this clip on both sides.



- Now remove the 5 bolts ● and 2 clips ● that hold the upper edge of the bumper in place



- The bumper is now only held in place with a few clips under the head lights. Pull the bumper forward firmly to release the clips. Before completely removing the bumper, disconnect the wiring going to fog light and turn signals.



### 13. Disconnect heater hoses

- Connect a small hose to the tap on the bottom of the radiator and loosen the radiator cap.
- Drain the engine coolant into a suitable container.
- Disconnect the throttle body heater hoses from throttle body.

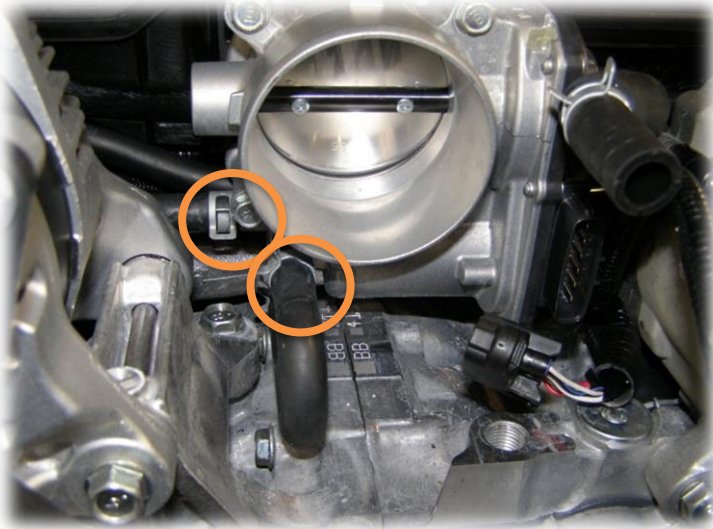

### 14. Remove manifold

- Remove the 6 screws from the intake manifold flanges (x3 on each bank) and carefully lift the intake manifold from engine.
- Cover the intake ports with rags or tape to prevent foreign objects falling into the engine.
- Remove the belt guards from the alternator and air conditioner pump
- Use a 14mm spanner to release the belt tensioner and remove the drive belt from the engine.
- Remove the brake booster hose, hard pipe and the bracket (manual transmission only).

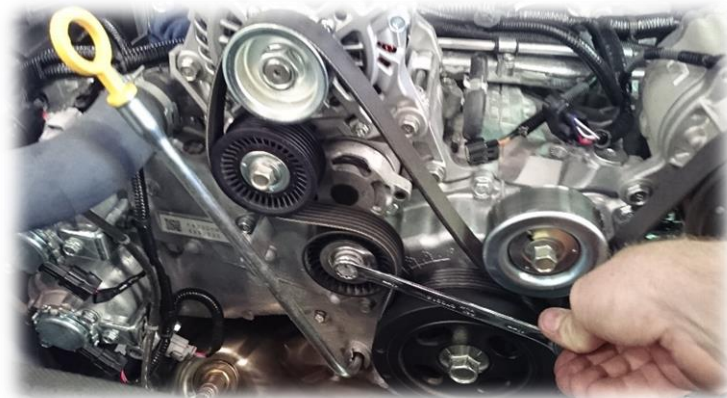

## 15. Remove the EVAP solenoid

- Remove the EVAP solenoid and hoses from the manifold. Remove the throttle body and fuel rails from the intake manifold. Ensure that the injector seals are removed from the manifold and set aside for reinstallation to the supercharger system later.
- Remove the 2 throttle body heater hoses from the engine. Remove the spring band clamps from the original hoses. Put these aside to re-use later upon installation.

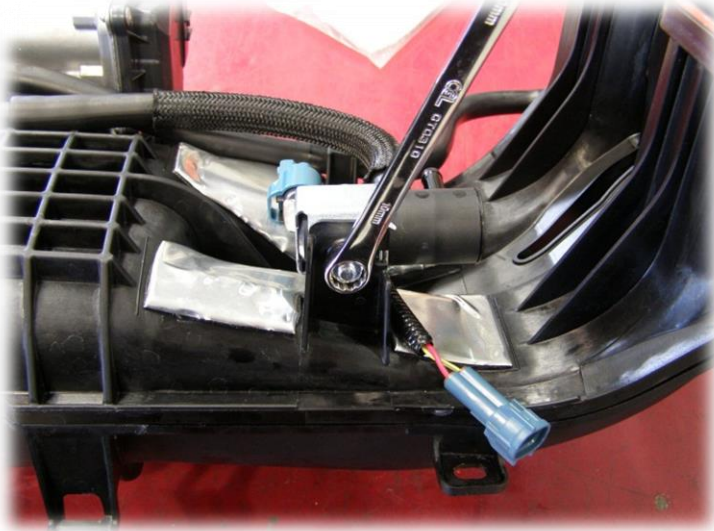

## 16. Remove the sound pipe

- Remove the sound pipe from the engine bay. Note that the hole in the firewall will need to be blanked off.
- From inside the cabin carefully pull down the carpet in the right hand side foot-well to expose the firewall hole where the sound pipe was previously located.
- Plug the hole with the grommet supplied in the kit.



## 17. Replace brake booster hard line

- **Note:** This process applies to left hand drive vehicles with automatic transmission only. The following is not required on manual vehicles (LHD or RHD) or on RHD automatic vehicles.
- Disconnect the brake vacuum hoses from the hard line (see picture).
- Remove fasteners & lift out brake booster hard line.
- Using the vacuum brake hose, connectors & hose clamps supplied, make up a suitable replacement flexible line. The hose may need to be trimmed to a suitable length.
- Route the hose away from where the supercharger manifold will sit & fasten with the cable ties supplied.

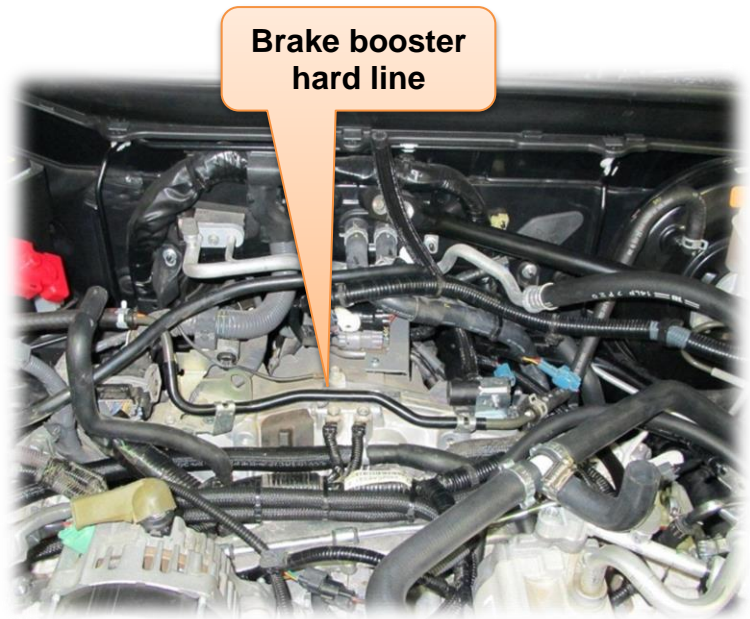

## 18. Remove strut braces

- Remove the 2 screws and 6 nuts that retain the strut braces, remove the strut braces from the vehicle and set aside.



**TOYOTA 86 / SUBARU BRZ / SCION FR-S**  
**SUPERCHARGER SYSTEM**

**SECTION 2**

**INSTALLATION INSTRUCTIONS**

## 19. Install the engine breather hose

- Attach the 12mm (1/2") ID, 700mm long engine breather extension hose to the OEM engine breather hose. Route the hose supplied as shown in the picture.

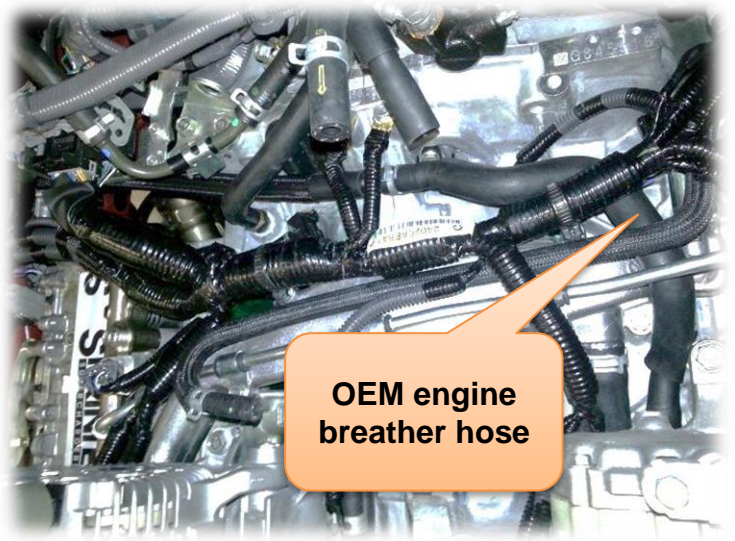
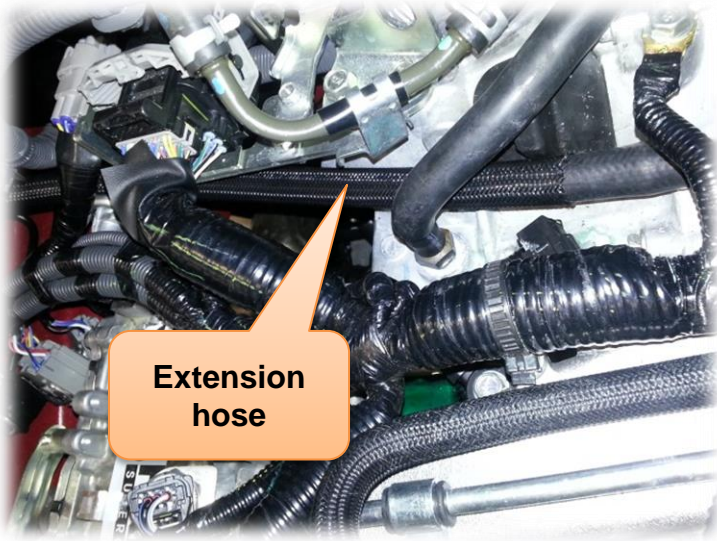

## 20. Install throttle body heater hoses

- Attach the spring band clamp to the new throttle body heater hoses. Install the 900mm long heater hose to the outlet on the rear of the engine (see image below). Ensure the clamp is secured correctly.
- Attach the 800mm long heater hose to the outlet (see image below). Secure the hoses in place with the cable ties supplied in the kit.

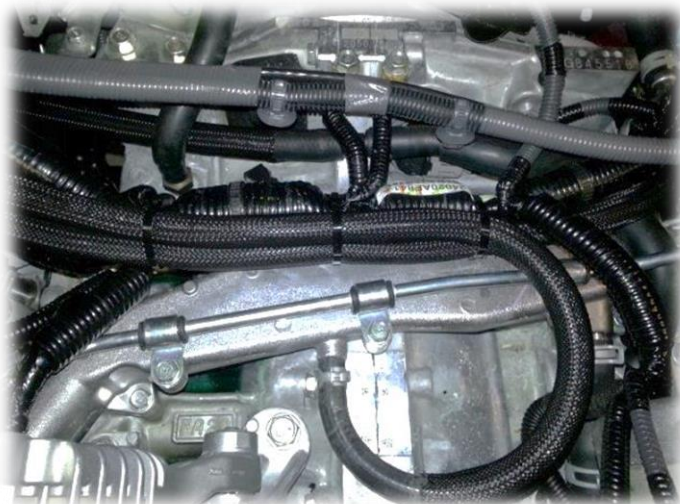

## 21. Install EVAP solenoid

- Attach the EVAP Solenoid to the relocation bracket supplied (see image).
- Secure the EVAP solenoid bracket to the engine with the SHCS M8 x 1.25 x 16 ZP supplied in the kit. Tighten to 23Nm.
- Attach the 520mm tank purge line to the solenoid. Attach the other end of the hose to the steel tank purge line. Route the hose as shown in the image.
- Attach the 330mm long vacuum hose to the solenoid. The other end of this hose will be attached to the supercharger intake once installed.
- Re-connect the EVAP Solenoid wiring to the wiring loom.

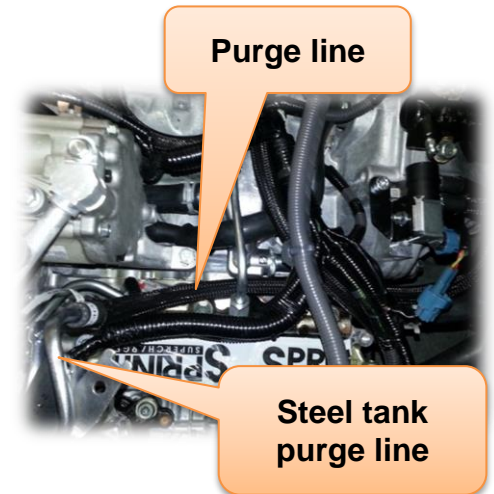

## FITTING SUPERCHARGER MANIFOLD

## 22. Install throttle body loom extension

- Attach the throttle body loom extension to the throttle body connector and tuck the extension behind the alternator.





## 23. Attach the MAP sensor loom extension

- Attach the MAP sensor loom extension to the MAP sensor connector and lay the extension towards the firewall.

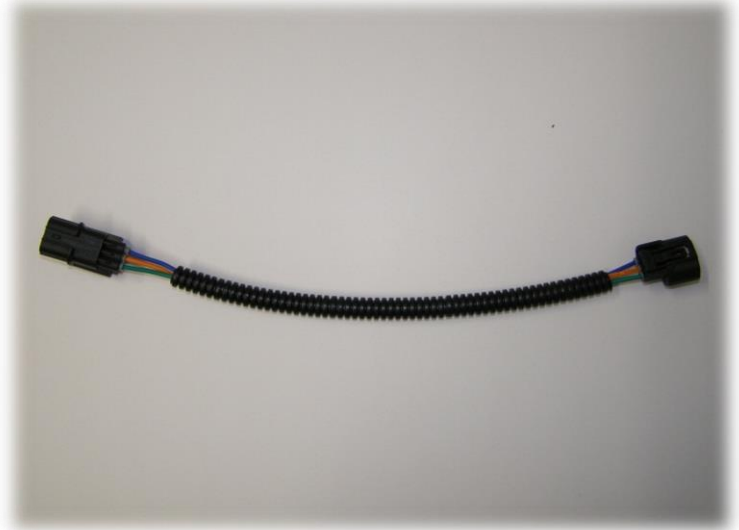

## 24. Attach wiring harness relocation bracket (Automatic Transmission Only)

- Carefully remove the automatic transmission harness connector from its mounting bracket.
- Attach the wiring harness relocation bracket to the existing bracket with the self-tapping screw supplied in the kit.
- Reattach the harness connector to the new bracket.

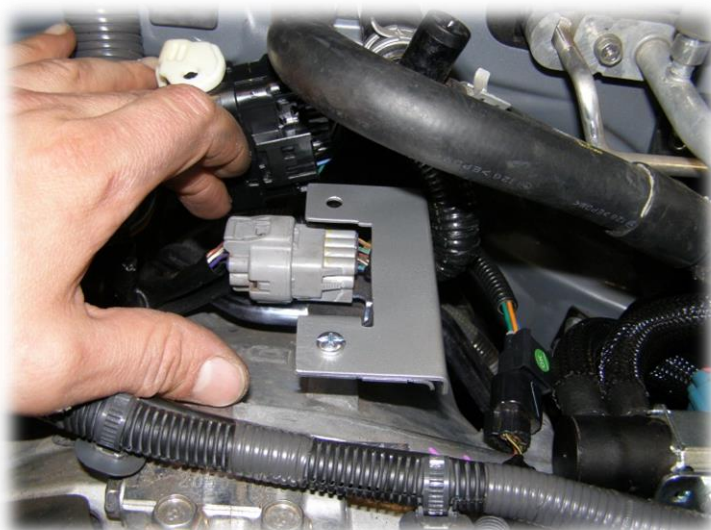

## INTERCOOLER SYSTEM INSTALLATION

### 25. Water pump installation

- Attach the water pump to the bracket with the 300mm heavy duty cable tie supplied in the kit.
- Attach the bracket, pump and loom to the front left hand side of the engine with the 2x SHCS M6 x 1 x 12 ZP supplied (see image). Tighten to 11Nm.

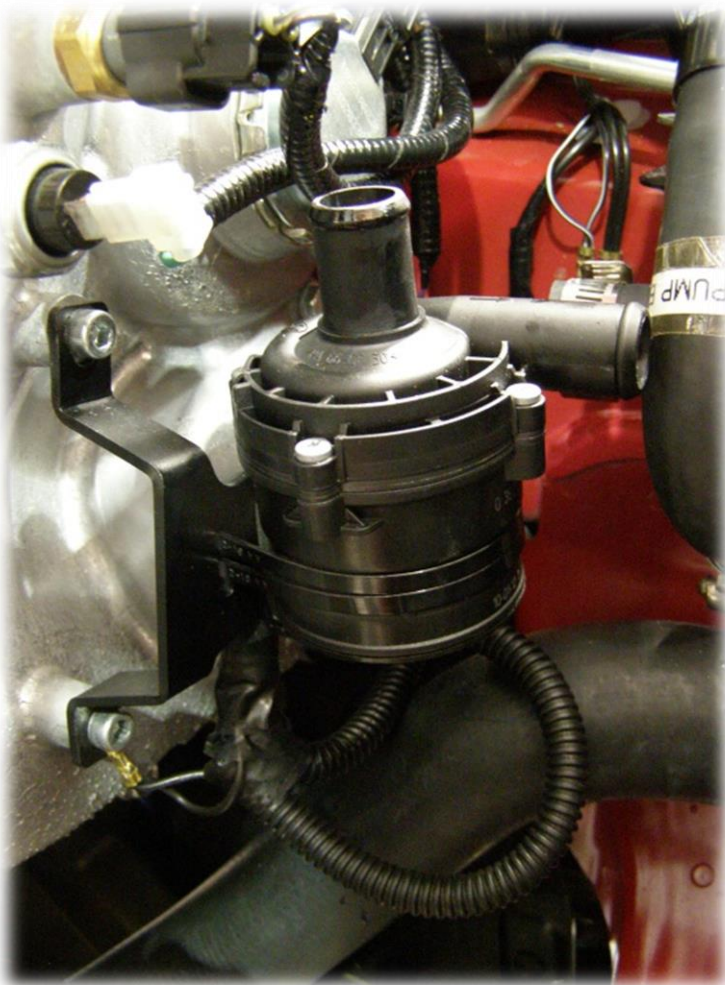

## 26. Install the Intercooler hoses

- Fit the six supplied 26mm spring clamps to the ends of all the intercooler water hoses.
- Lay the intercooler return hose into the engine bay towards the firewall, attach the forward end to the top of the water pump.
- Fit the short hose to the pump outlet and route the other end of this hose down beside the vehicles radiator ready to be fitted to the top hose connection of the radiator.
- Lay the intercooler inlet hose into the engine bay towards the air conditioner pump. Route the other end of the hose down alongside the washer bottle between the inner guard and outer panel. Feed the hose through ready to be connected to the bottom radiator fitting.
- Tighten all the hose connections with the hose clamps supplied.

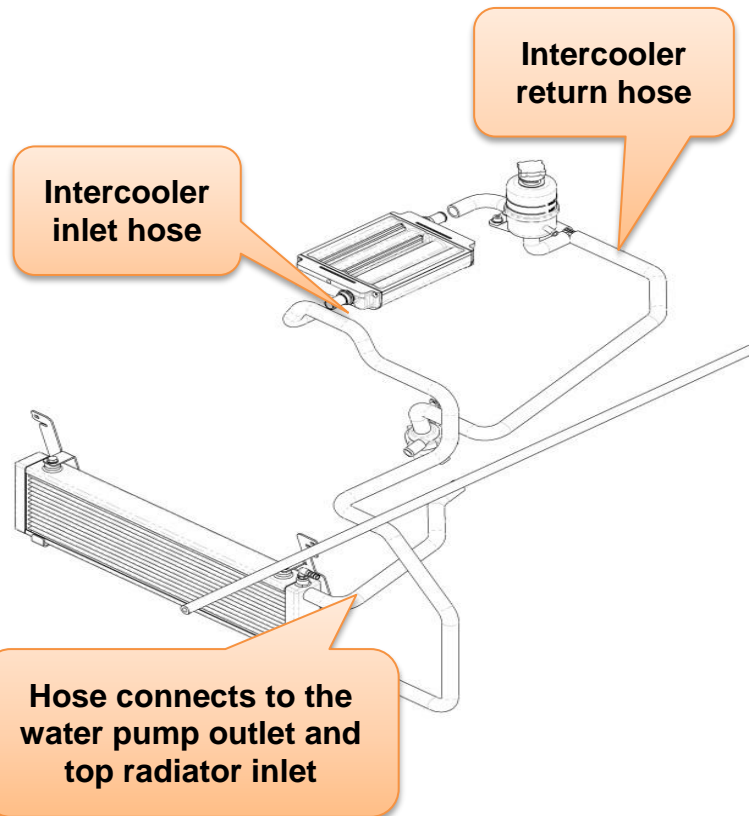

- Cut out a 35mm wide x 40mm high hole in the RHS plastic panel next to the air conditioner condensor. This will allow the bottom radiator hose to pass through when the radiator is installed.

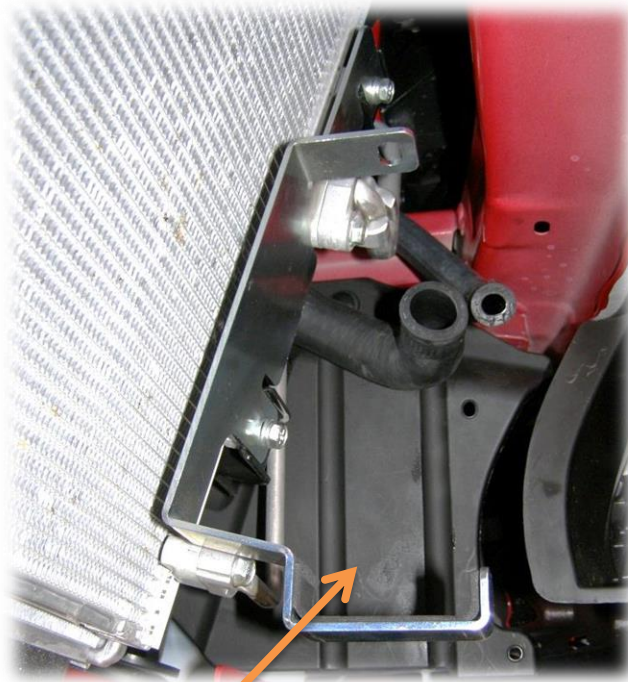

## 27. Intercooler radiator installation

- Install the ¼ x 10 Male Elbow Plastic to the radiator as shown below. Apply thread sealant to the thread of the elbow upon assembly.
- Install the radiator support pins (x2).
- Remove the four screws that retain the air conditioner condenser. Also remove the screw that retains the horn.
- Fit the supplied Grommet (2x) to the top radiator brackets.
- Install the radiator bracket onto the condenser mount bracket and retain with the OEM fasteners.
- Connect the 10mm (3/8") x 1200mm long radiator hose to the plastic elbow on the radiator. Feed the hose into the gap beside the vehicle's radiator whilst offering up the radiator into the support brackets. Route the hose towards the firewall.
- Fit the radiator by inserting the radiator support pins into the bracket grommets.
- Connect the corresponding coolant hoses to the radiator fittings.
- Fit the 2 bottom brackets & fix to the top brackets with the SHCS M6 x 1 x 20 ZP screws provided.
- Reattach the horn in its original position.

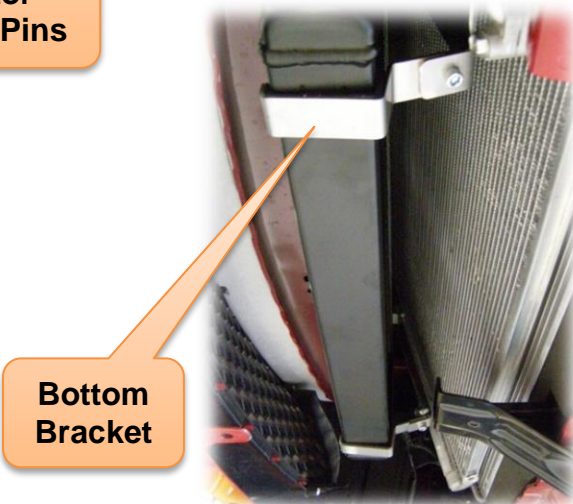
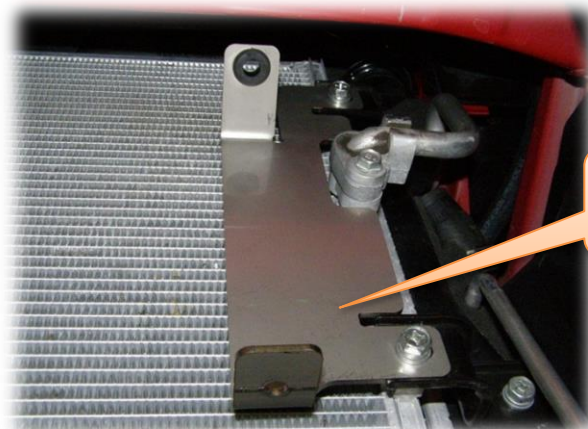
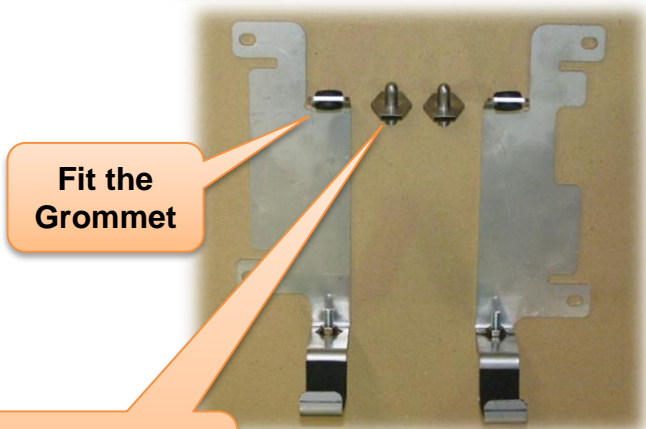
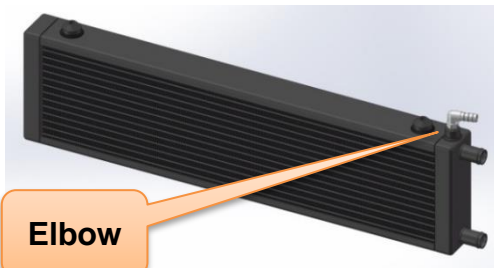

## 28. Install idler pulley

- **NOTE:** Systems equipped with a Ø80mm or larger supercharger drive pulley require the Ø60mm idler pulley to be fitted without a bearing shim. Systems equipped with a Ø75mm or smaller supercharger drive pulley require the Ø70mm idler pulley to be fitted. If a Ø70mm idler pulley is to be fitted, it requires the supplied bearing shim to be installed on the pulley mount behind the bearing.
- Remove the bolt from the alternator mount.
- Attach the supplied idler pulley mount, idler pulley, M8 x 170 Hex. head bolt and Dia.24 x Dia. 8.5 x 4mm retaining washer to the alternator. Tighten to 23Nm.

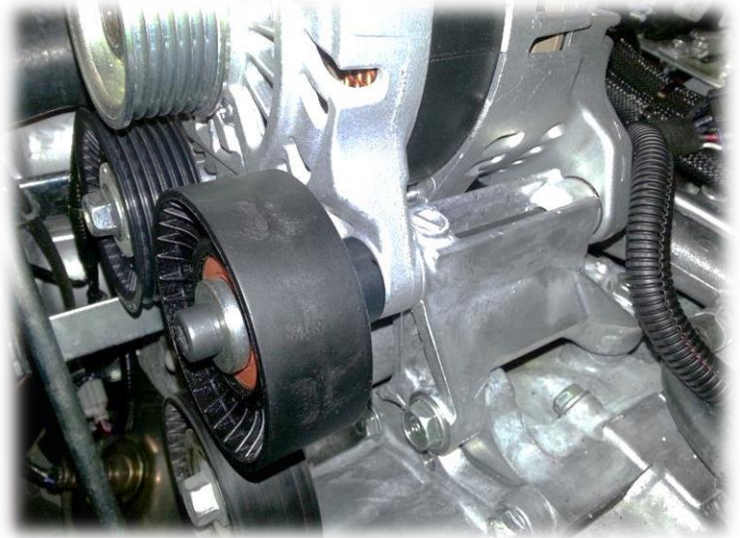
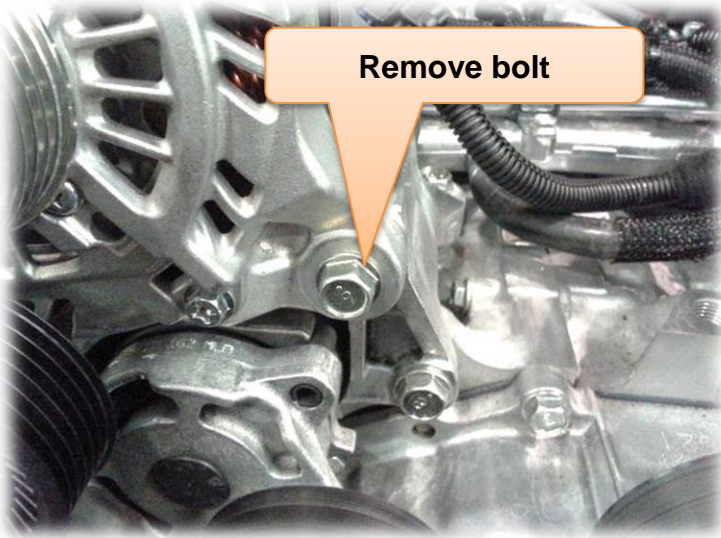

## 29. Install vacuum fittings

**Note:** This step is only required if fitting a FT86 335+ system.

- Prior to installing the manifold, fit the vacuum fittings supplied into the supercharger intake manifold. Please take note of the fittings orientation when installing.
- Apply thread sealant to brass fitting prior to installation.

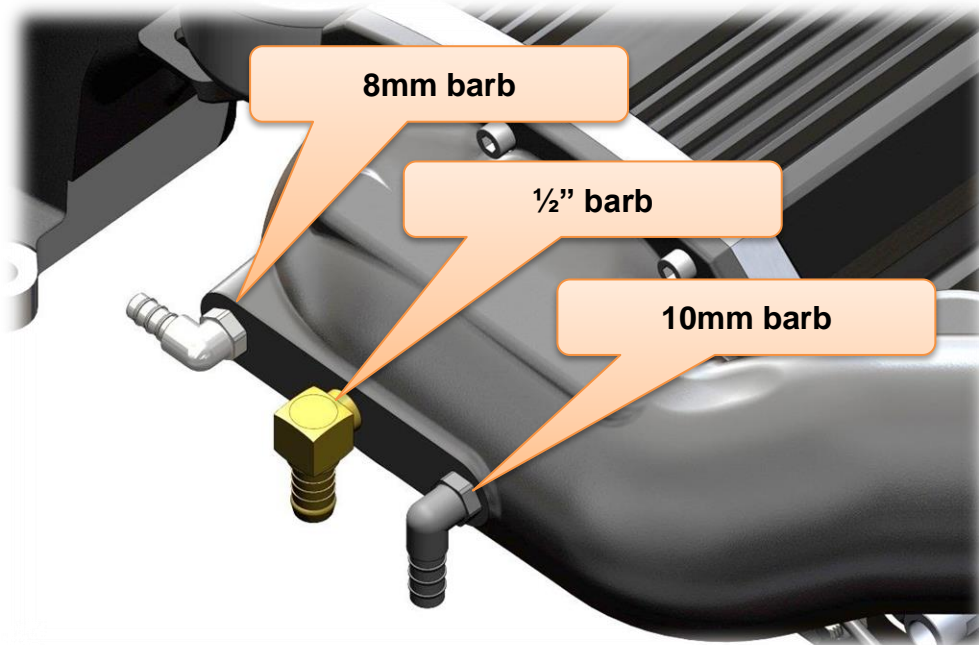

## 30. Install fuel rails

- Remove all protective film from the intake manifold
- Install the injector seals, injectors, and fuel rails onto the supercharger manifold. Prior to installing the seals into the supercharger manifold, apply rubber grease to the seals to prevent damaging the seals upon assembly.
- Turn the supercharger manifold upside down onto a clean rag, to prevent marking the supercharger. Install the BS144 manifold seals supplied. Apply rubber grease to the O-rings prior to assembly.
- Turn the supercharger back over.
- Install the BS147 throttle body seal and throttle body onto the supercharger manifold. Attach the throttle body with the OEM fasteners and tighten to 12 Nm.

**Note:** This step only required on systems with a S5-210 supercharger.

- Attach the supercharger intake vacuum hose to the vacuum actuator.



## 31. Test fit the supercharger manifold

- Carefully lower the supercharger manifold into place (**2 PERSON LIFT**). Check the clearance around the alternator. It may be necessary to file the corner of the alternator bracket. This will ensure that the supercharger manifold sits flat on the cylinder heads.
- Ensure the intake ports are covered before filing the corner of the alternator.
- Position the throttle body plug so that it can be accessed once the manifold is in place.
- Place the fuel crossover pipe across the front of the engine behind the alternator and air-conditioning pump.
- Lower the manifold into place and secure the manifold in place with the 6 OEM fasteners.
- Secure the manifold with the M14 x 1.5 x 40 hex head bolt. Tighten to 65Nm.
- On left hand drive automatic vehicles check that the brake booster vacuum line (fitted earlier) is clear of the supercharger kit & fastened appropriately.

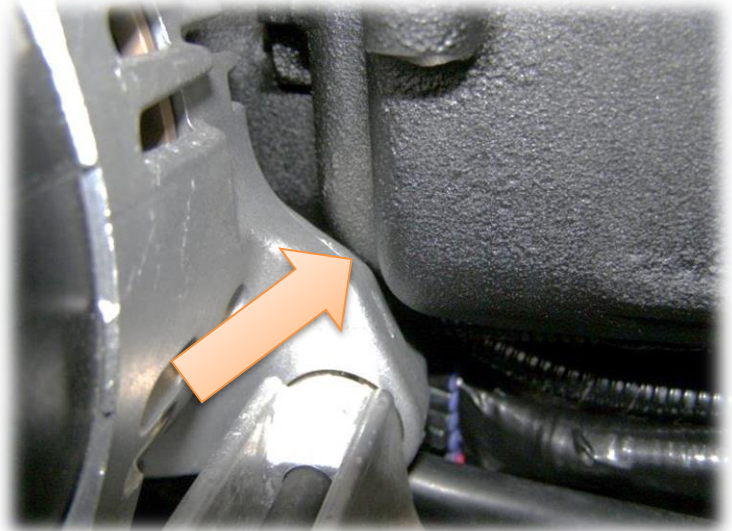



### 32. Attach throttle body connector

- Connect the electrical connector to the throttle body.



### 33. Install supercharger pulley

- **Note:** skip this step if fitting a FT86 335+ system as this system comes with the pulley pre-fitted.
- Install the supplied pulley to the pulley mount on the supercharger, using the four M6 x 20 SHCS and flat washers supplied. Tighten to 12Nm.

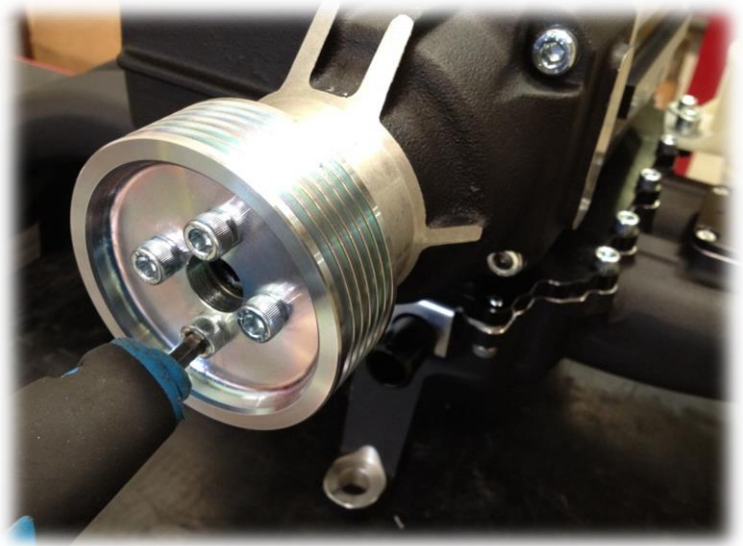

### 34. Attach heater hoses

- Connect the throttle body heater hoses to the throttle body. Ensure the hose clamps are installed correctly.



### 35. Install drive belt

- Use a 14 mm spanner to relieve the tension on the dynamic tensioner and install new drive belt. Follow the belt routing diagram (right) and ensure that the belt is properly installed on each pulley.
- Reinstall the belt guards on the alternator and air conditioner pump.

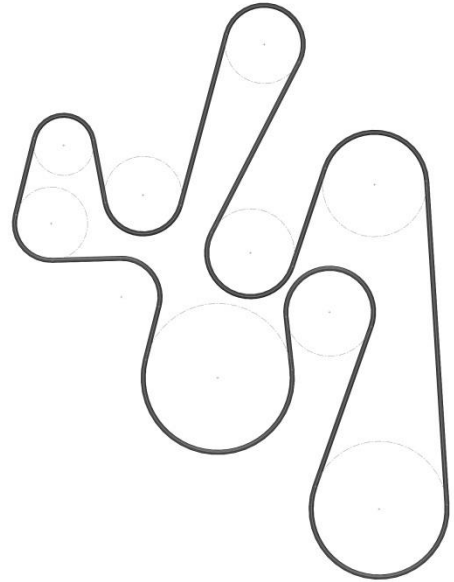

### 36. Connect fuel supply line

- Reconnect the fuel supply lines on both sides of the engine. Ensure that the locking tab is fully depressed.
- Reconnect the injector connectors on both sides of the engines and reconnect the high pressure fuel pump connector on the left hand side.
- Connect the water pump loom via the adaptor connectors to one of the fuel injector connectors.
- Install the ECU mount and secure with the OEM fasteners. Attach the right hand side injector cover and secure with the OEM fasteners.
- Reattach the ECU and secure with the OEM screws.
- Attach the fuel rail support bracket.

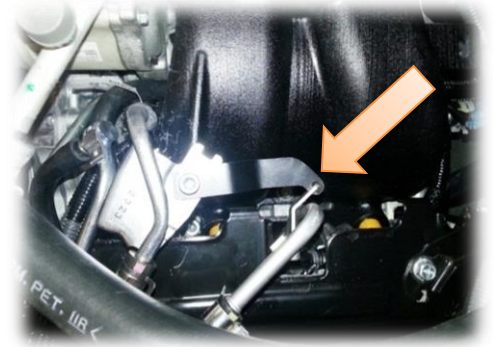

### 37. Attach MAP sensor connector

- Install the MAP sensor and attach the MAP sensor extension loom.

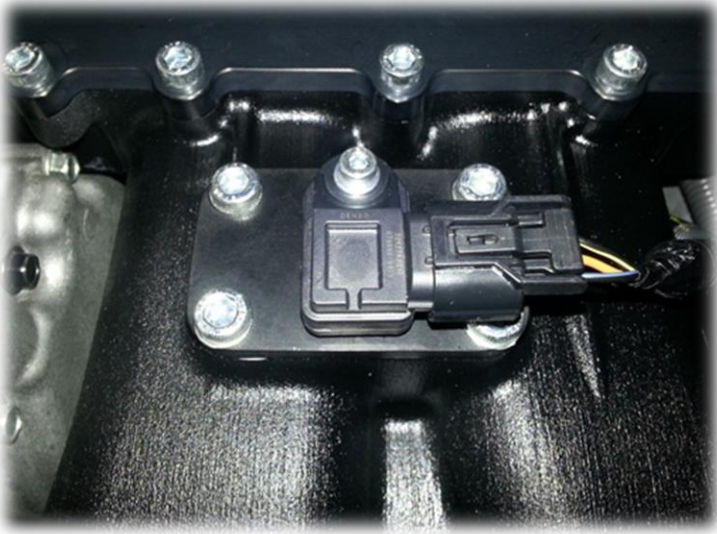

## ATTACH THE INTERCOOLER HOSES

### 38. Connect intercooler hoses

**Note: Non- intercooled systems skip this step.**

- Connect the hoses to the intercooler fittings. Secure with the hose clamps supplied.
- Connect the overflow bottle to the intercooler outlet hose. Secure with the hose clamps supplied.
- Connect the 10mm (3/8") hose to the spigot of the overflow bottle. Secure with a hose clamp.
- Fill the intercooler system via the overflow bottle with 2200ml (74.4 fluid oz.) of ethylene glycol based automotive engine coolant approved for use in aluminium engines.
- Temporarily connect the battery, turn the ignition to the run position but do not start the engine and confirm that the intercooler water pump is running. With the pump running continue to fill the system until all of the 2200ml of coolant is used. This step is important as the intercooler will perform poorly and restrict the engines performance if air remains in the system. It may be necessary to drive the vehicle or 'work' the hoses to eliminate all the air from the system.
- Check all intercooler hose connections for leaks.
- Once the pump has been tested, disconnect the battery again.

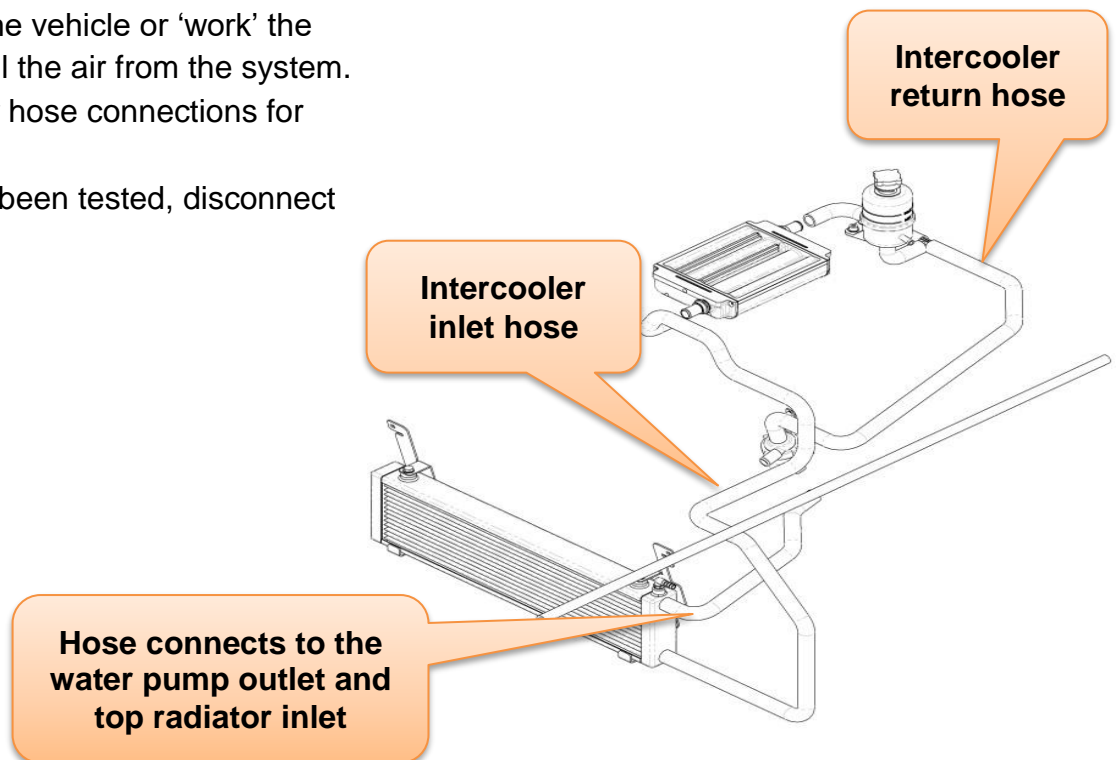

## 39. Fit breather hoses

- Attach the loose end of the EVAP solenoid vacuum hose to the supercharger intake.
- **Note:** Ensure that the braided vacuum hose is routed as shown below and is not touching surrounding hoses (including the aluminium air conditioning pipes). This is to ensure the braided hose does not cause damage through abrasion to surrounding components.

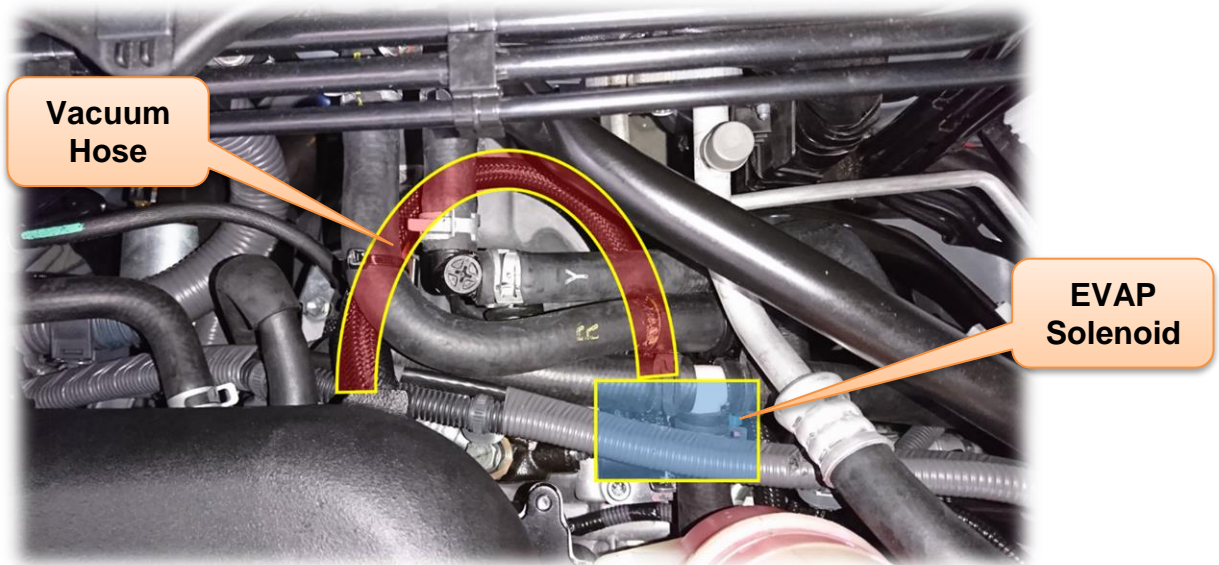

- Attach the engine breather hose to supercharger intake.
- **Note:** This step not required for automatic transmission vehicles. Attach one end of the brake booster hose supplied to the supercharger intake and attach the other end to the brake booster. Attach with the OEM spring band clamp from the original hoses. Ensure that the vacuum check valve supplied with this hose is oriented correctly ('To Motor' arrow on the check valve is installed towards the engine).
- **Note:** This step is for LHD vehicles only. Twist one of the hoses in the assembly by 180° as per the picture prior to assembly.
- **Note:** This step is for automatic transmission vehicles only.
- Remove the blanking plug from the factory manifold and blank the brake booster elbow (see the images over the page for detail).

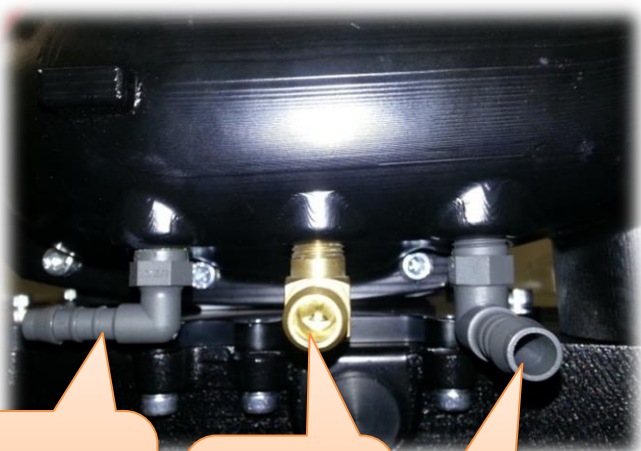

Connect to  
EVAP  
Solenoid

Connect  
to engine  
breather

Connect  
to brake  
booster

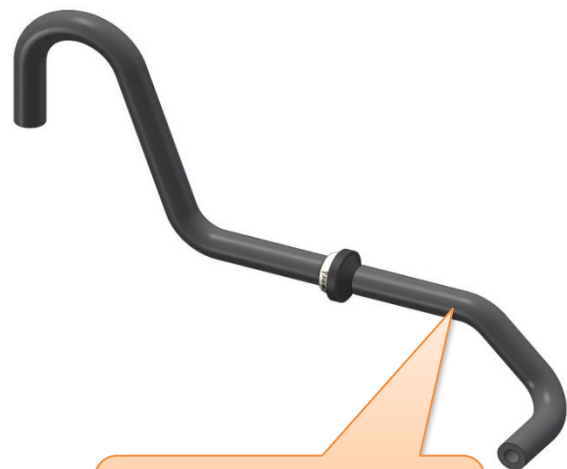

Rotate 180° for LHD  
vehicles only.

## 40. Fit the inlet pipe

- Re-fit the air box.
- Attach the inlet pipe to the throttle body and the air box with the silicon couplers and hose clamps supplied.
- Connect the engine breather extension hose to the inlet pipe.



## 41. Reinstall the strut braces

- Reinstall the strut braces taking care to note the correct orientation as stamped on the ends of the strut braces.
- Secure using the 2 screws and 6 nuts previously removed



## 42. Modify bonnet (hood) insulation

- The under bonnet (hood) insulation must be removed or modified to prevent the supercharger drive pulley contacting the insulation during some operating conditions.
- Make a card board or paper template 100mm x 125mm.
- Place a piece of double sided tape onto the centre of the template.
- Lay the template onto the supercharger pulley with the tape side up make sure that the template is central to the pulley.
- Close the bonnet.
- Lift the bonnet. The template should be attached to the bonnet lining. Mark out around the template and cut out a section of the bonnet insulation. The cut edges should be covered with pinch weld or fabric tape (not included) to prevent the edges fraying.
- **Note: Sprintex recommends simply removing the under bonnet insulation, as this allows it to be refitted unmodified at a later date if required.**



### 43. Refill the cooling system

- Ensure that the drain tap is closed, Set the cabin heater control to 'hot' and refill the radiator with the drained coolant or replace with fresh coolant.
- Take care to ensure the cooling system is bled properly. Note the bleed valve located on heater hoses to help with the bleed process

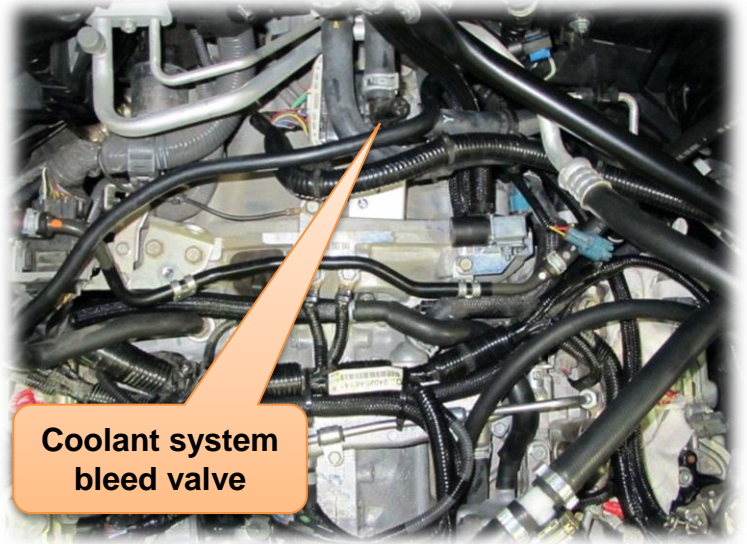

### 44. Refit Front Bumper

- Refit the front bumper and under tray. See steps 11 and 12 of this manual and follow the procedure in reverse.

### 45. Reconnect battery

- Reconnect the battery terminals.
- **Note: Battery positive terminal should always be connected before the negative terminal.**

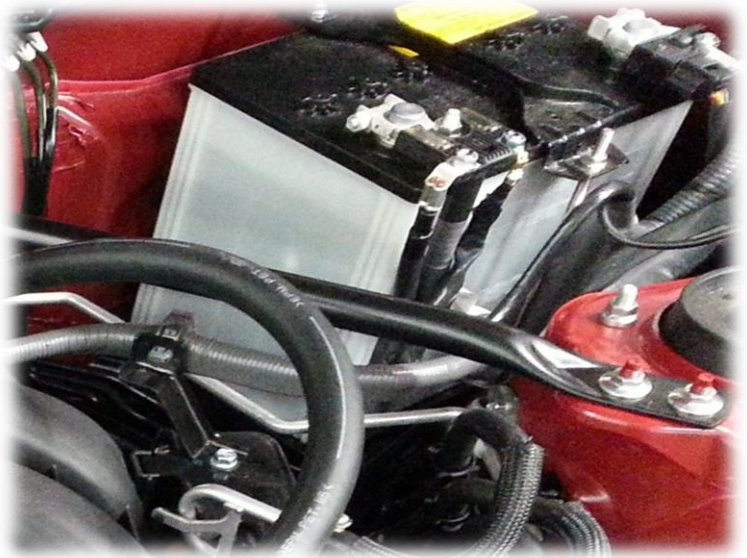



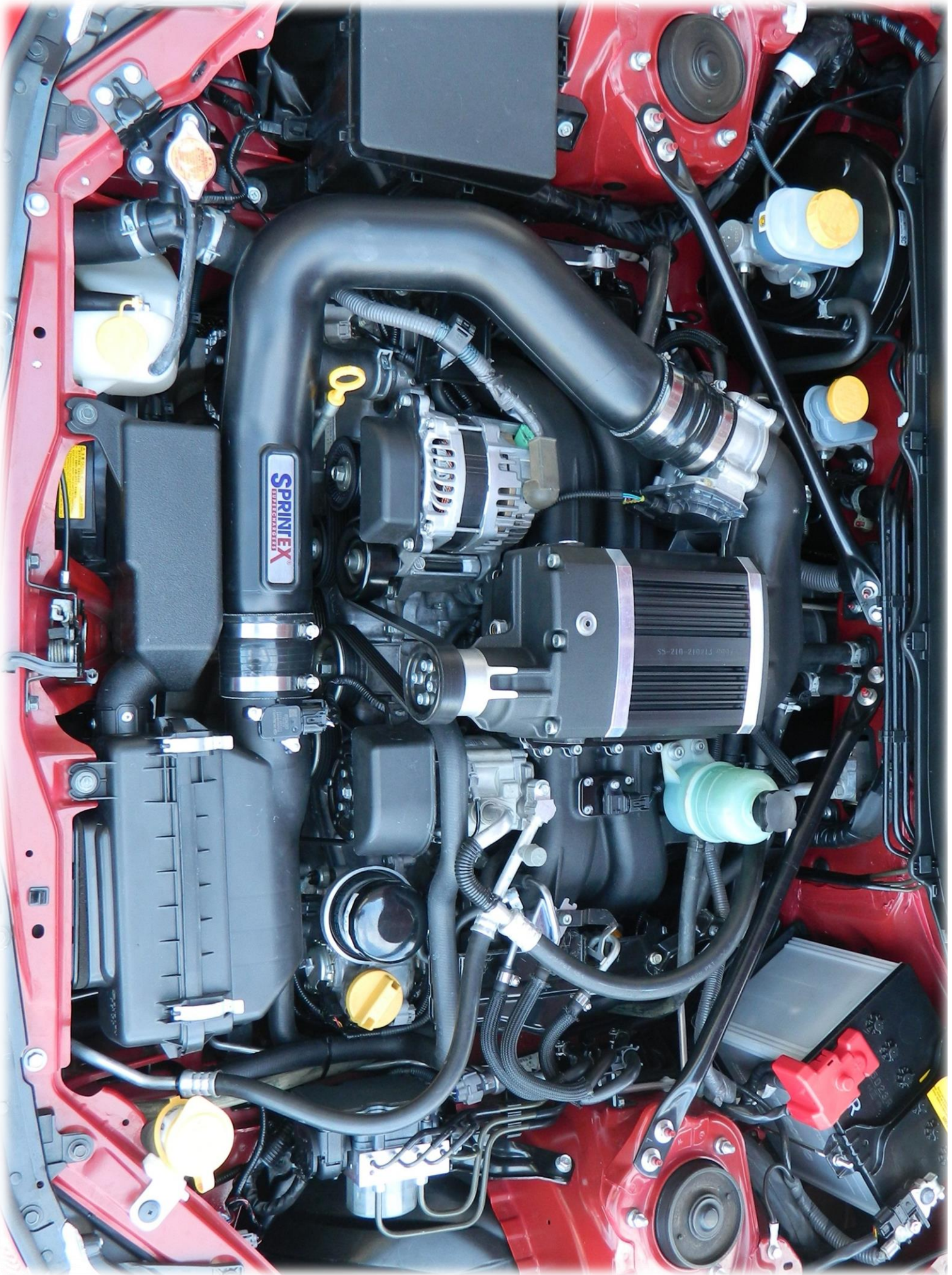

**TOYOTA 86 / SUBARU BRZ / SCION FR-S**  
**SUPERCHARGER SYSTEM**

**SECTION 3**

**PRE TEST-DRIVE INSPECTION**

## 46. Pre-start inspection

- Ensure the coolant is at the correct level.
- Ensure the engine oil is at the correct level.
- Ensure the vehicle has fresh 98 RON (91 Pump Octane USA) premium unleaded fuel or higher.
- Ensure the belt is aligned.
- Ensure the air filter is clean.
- Check & replace spark plugs if necessary. Set the gaps to factory spec.

**SAFETY WARNING:** Ensure adequate steps are taken to prevent injury, spillage or fire should any of the required installation steps not have been carried out to specification.

## 47. Engine warm up

- Start the engine and allow it to run until it reaches normal operating temperature.
- Check for leaks.
- (Intercooled systems only) Check the intercooler overflow bottle coolant level with the engine running and top up the system with the remainder of the 2200 ml of coolant. If the system does not take the full 2200 ml of coolant there must be an air lock in the system. Top up the system once the vehicle has been taken for a test drive.
- Check the engine coolant level.

## 48. Road test vehicle

- Road test vehicle.
- Recheck all joints and connections for leaks –rectify as needed.
- (Intercooled systems only) Check intercooler system coolant level.

**TOYOTA 86 / SUBARU BRZ / SCION FR-S**  
**SUPERCHARGER SYSTEM**

**SECTION 4**

**MAINTENANCE INSTRUCTIONS**

## 49. Supercharger drive belt replacement

- It is recommended that the supercharger drive belt be checked at every regular service and is replaced at 50,000 km (30,000 miles) or 2 years, whichever occurs first.
- Follow the routing diagram detailed below.

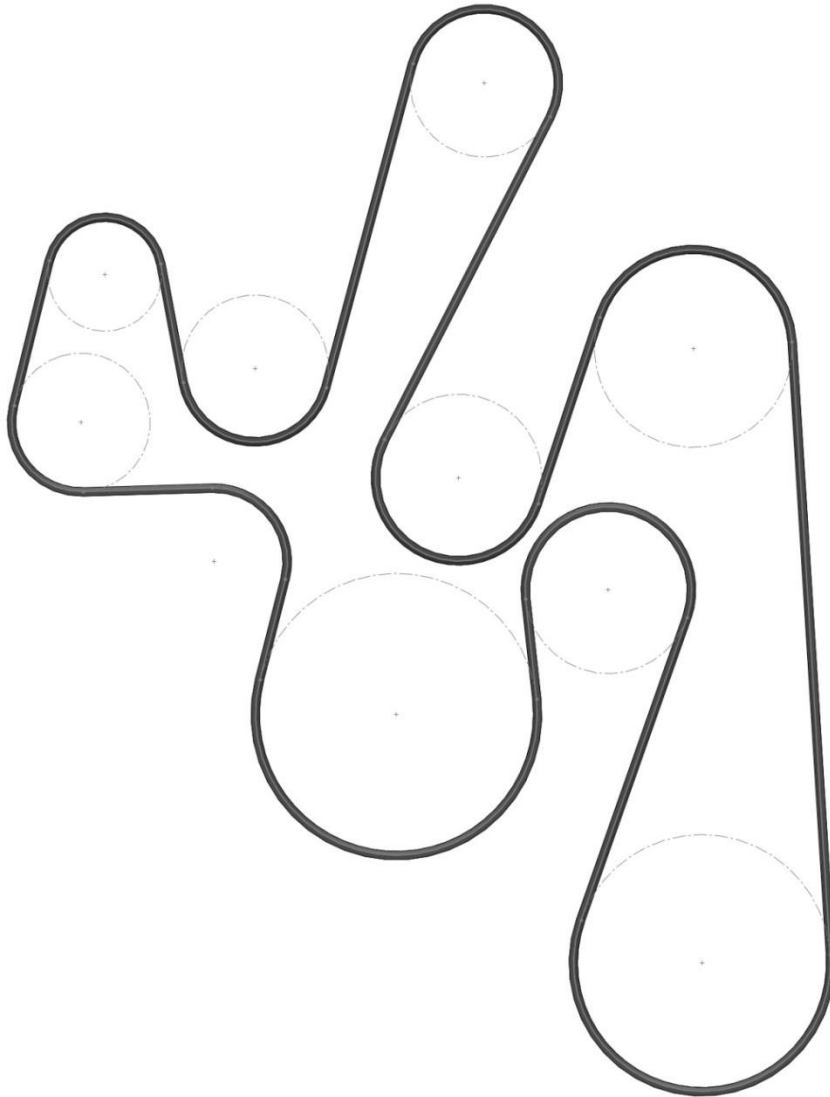

- Use a 14mm wrench to release the dynamic tensioner to remove & replace the belt.

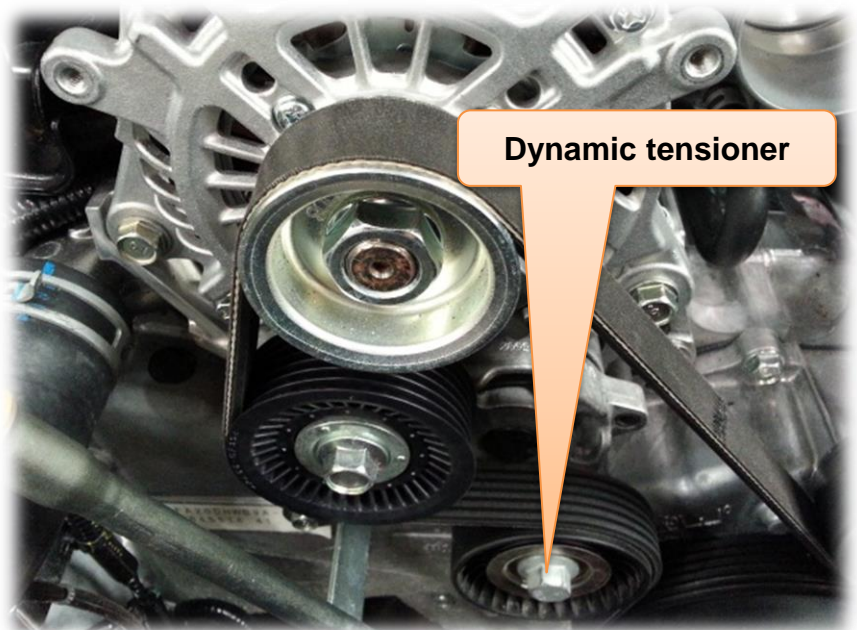

## 50. Supercharger gearbox oil change interval

- Drain and replace the supercharger oil every 50,000 km or 30,000 miles. Use Redline 75W90 NS gear oil or an equivalent spec. lubricant.  
It is critical not to overfill the supercharger gearbox as damage will occur. Fill with exactly **157 millilitres or 5.31 US fluid ounces.**
- Ensure the vehicle is parked on level ground before checking the oil level. Check the oil level with the dipstick provided in the supercharger assembly. Tighten the dipstick fully before checking the oil level.



## 51. Supercharger gearbox oil change procedure

- Ensure the vehicle is parked on level ground before checking the oil level.
- Remove the dipstick from the gearbox.
- Using a syringe and a 120mm long piece of tube draw out as much oil as possible from the gearbox.
- Fill the gearbox with a quality fully synthetic SAE 75W-90 gear oil, specifications: API GL5, MT1 such as: Redline 75W90 NS gear oil (factory fill), Castrol Syntrax Universal Plus 75W-90, Lucas synthetic SAE 75W-90 gear oil or equivalent.
- Check the oil level with the dipstick.
- Refit the dipstick and tighten to 10Nm.
- Note that an oil level sight glass is provided for easy regular oil level checks. It is recommended that the oil is checked every day. Oil should be visible through the sight glass.

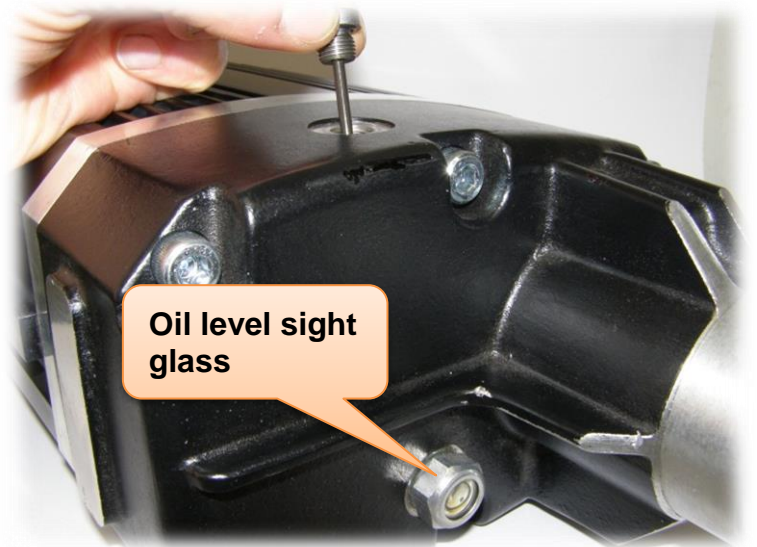

<b>Document No.</b>	260_5D1000
<b>Title.</b>	Toyota 86 / Subaru BRZ / Scion FR-S supercharger system installation instructions.
<b>Revision.</b>	1.4
<b>Approved by.</b>	
<b>Date.</b>	